

ARCHITECTURAL SEQUENCE AND CHRONOLOGY

AT CHAVIN DE HUANTAR, PERU

A DISSERTATION

SUBMITTED TO THE DEPARTMENT OF ANTHROPOLOGICAL SCIENCES

AND THE COMMITTEE ON GRADUATE STUDIES

OF STANFORD UNIVERSITY

IN PARTIAL FULFILLMENT OF THE REQUIREMENTS

FOR THE DEGREE OF

DOCTOR OF PHILOSOPHY

Silvia Rodriguez Kembel

June 2001

© Copyright by Silvia Rodriguez Kembel 2001

All Rights Reserved

I certify that I have read this dissertation and that, in my opinion, it is fully adequate in scope and quality as a dissertation for the degree of Doctor of Philosophy.

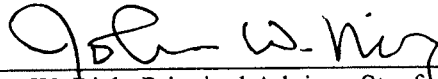

John W. Rick, Principal Adviser, Stanford University

I certify that I have read this dissertation and that, in my opinion, it is fully adequate in scope and quality as a dissertation for the degree of Doctor of Philosophy.

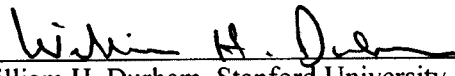

William H. Durham, Stanford University

I certify that I have read this dissertation and that, in my opinion, it is fully adequate in scope and quality as a dissertation for the degree of Doctor of Philosophy.

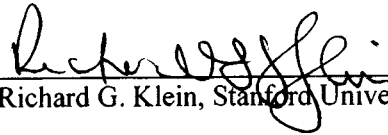

Richard G. Klein, Stanford University

I certify that I have read this dissertation and that, in my opinion, it is fully adequate in scope and quality as a dissertation for the degree of Doctor of Philosophy.



Luis G. Lumbreras, Universidad Nacional Mayor de San Marcos, Lima, Perú

I certify that I have read this dissertation and that, in my opinion, it is fully adequate in scope and quality as a dissertation for the degree of Doctor of Philosophy.



Jean-Pierre Protzen, University of California, Berkeley

Approved for the University Committee on Graduate Studies:

ABSTRACT

The architectural sequence and chronology of the monumental center at Chavín de Huántar, located in Perú's north-central highlands, has long been a consequential issue in Andean archaeology. I demonstrate that Chavín's construction differed significantly from the three-phase sequence previously postulated. A simple Old Temple-New Temple distinction neither sufficiently nor accurately represents the complexity of Chavín's sequence.

My research presents a new methodology for studying the complexity of monumental architecture. New field methods enabled precise, three-dimensional documentation of Chavín's internal and external architecture, while new analysis methods enabled systematic study of the architecture's spatial relationships. With these methods I elucidated construction principles, isolated construction phases, and determined a new architectural sequence for Chavín.

I demonstrate that Chavín was built in a complex sequence of at least fifteen phases, grouped into five stages. Early construction of high-volume structures containing gallery patios and elaborate galleries shifted, in the final monumental construction stage, to construction of lower-volume structures containing standardized galleries and all known plazas. This pattern suggests a shift towards activities that required large, decorated external spaces, rather than elaborate internal spaces associated with small patios. Throughout, galleries continued functioning, and evidence suggests that the Lanzón monolith maintained importance. Staircase symmetry and significant modifications to earlier constructions characterize all stages. Highland architectural forms were constructed early and later incorporated with coastal architectural forms.

Key areas previously thought to be early were built in the final monumental construction stage; these include the Ofrendas Gallery and the Circular Plaza. Dates from associated radiocarbon samples suggest monumental construction was nearing completion by approximately

750 B.C., rather than beginning. Ofrendas ceramics are associated with this final monumental stage. The original architectural anchor-points of Chavín's sculptural sequence retain their relative positions. Evidence of structural destabilization exists by approximately 500 B.C., followed by evidence of disuse and physical collapse.

These results suggest that Chavín was coeval with other monumental centers of the late Initial Period and early Early Horizon, and had significantly declined, with many coastal centers, by approximately 500 B.C. Chavín likely was neither a "mother culture" antecedent to these centers, nor the late consequence of their decline.

*to my husband
John Kembel
and
my parents
Juan and Alicia Rodriguez*

ACKNOWLEDGEMENTS

My dissertation research at Chavín de Huántar was supported by National Science Foundation Doctoral Dissertation Improvement Grant #SBR-9802307, National Geographic Society Committee for Research and Exploration Grant # 6331-98, and a Stanford University Morrison Institute for Population and Resource Studies Research Grant. Dissertation write-up was supported by a Stanford University McCoy Charitable Foundation Dissertation Fellowship and a Stanford University Graduate Fellowship from the Department of Anthropology and the Department of Anthropological Sciences.

Many people deserve acknowledgement for the role they played in making this dissertation possible. I would like to start by thanking the members of my dissertation reading committee. Special thanks go to my main advisor, John Rick, for introducing me to the site of Chavín and for generously sharing his data from Chavín with me in a spirit of collaboration. His support and advice were instrumental in this project, and our conversations on topics from computers to complexity were particularly valuable. William Durham provided welcome comments and constructive criticism, reminding me to consider the cultural significance behind the architecture. Luis Lumbreras graciously spent time discussing Chavín and its architecture with me during his timely stay as a visiting professor at Stanford during the winter of 2001; I greatly appreciate his warmth, kindness, and advice. Richard Klein provided guidance and support throughout my graduate career, and made valuable suggestions regarding hypothesis testing in my research. Jean-Pierre Protzen helped me learn how to analyze architecture and ponder stonework, and engaged in stimulating discussions about how the galleries at Chavín were built. Ian Morris kindly served as the chair of my examination committee. Additionally, I would like to thank Rosa Mendoza Rick for her friendship, support, and assistance with the logistics of

fieldwork, as well as for allowing me to use her video-taped interviews with Marino Gonzáles regarding his work at Chavín.

Special thanks go to my field team, who helped document and map the galleries at Chavín. Heidi Hentila, John Kembel, Jeremy Kembel, Carlos Rodriguez, and Sarah Saffer spent countless hours in the galleries, sitting under collapsing ceiling beams and crawling in the dark through bat guano more times than I'm sure they care to remember. Led by the motto that "Anything's possible," they were instrumental in the successful completion of the fieldwork. John Kembel in particular deserves special recognition for designing the 1996 mapping system, helping to develop the custom databases for both seasons, and keeping computers and lasers functioning while deep within an ancient temple in the rural Andes.

In Chavín, Alejandro Espinoza Noceda, Marino Gonzáles Moreno, and Martín Justiniano provided assistance as well as information on recent work in the galleries. The Valencia family welcomed us, provided assistance, and kept us well-fed.

Technical support for the project was invaluable and came from many sources. The jig for the 1996 mapping system was expertly machined by Peter Johnson of Peter Johnson Machining. The DataDisto GSI and tripod for the 1998 season were provided by Hans Haselbach, Jr. of Haselbach Surveying Instruments. Diego Rodriguez and John Kembel designed and carefully machined alterations to that tripod so that it could be used for mapping in the confined spaces of the galleries. Professor Tom Kosnik of Stanford University facilitated the donation of laptop computers to the project by Texas Instruments. John Kembel helped prepare the illustrations in this dissertation, and programmed, with Jeremy Kembel, its web-based figure viewer.

I would like to acknowledge and express my gratitude and appreciation to John H. Rowe for providing permission to cite his unpublished field notes from his visits to Chavín in 1961 and 1963, and for providing permission to reproduce his 1967 construction sequence in this dissertation. Many thanks go to Pat Lyon for her assistance and advice.

I appreciate the assistance provided by other researchers of Chavín architecture. Elizabeth Burson provided me with copies of her notes and drawings from her study of Chavín stonework. Heidi Hentila, Stella Nair, and Jean-Pierre Protzen provided copies of their measurements and drawings in the galleries. Sarah Saffer graciously provided me with a copy of her thesis and data archive on the tenon head at Chavín.

I am grateful to my fellow graduate students Jill Fleuriet, Teresa Steele, Deborah Stratmann, Tim Weaver, and John Wolf for their support and friendship over the years. Julia, Michael, and Evelyn Webber provided friendship and comic relief.

I offer thanks that go beyond words to my family. My parents, Juan and Alicia Rodriguez, have provided me with endless love, confidence, and opportunities for which I will be forever grateful. My brother Juan and my sister-in-law Paige provided support, both intellectual and personal, as well as thoughtful comments and advice in the preparation of this dissertation. My brother Diego helped inspire my early interest in archaeology, by joining me in search of the Trojan War. My brother Carlos took the majority of the photos presented in this dissertation, with his careful photo documentation of the architecture of Chavín. Special thanks go to Jerry, Susie, George, Alice, Jeremy, and Geoff Kembel for their support and encouragement.

Finally, my husband John has been a never-ending source of encouragement, support, assistance, humor, and love. Additionally, his skills in engineering, computer programming, and design provided the technical foundation, both in the field and upon our return, that made this project possible. To him I give my most heartfelt thanks.

TABLE OF CONTENTS

ABSTRACT.....iv

ACKNOWLEDGEMENTS.....vii

CONTENTS.....x

TABLESxvii

ILLUSTRATIONSxviii

Chapter

1. INTRODUCTION, BACKGROUND, AND RESEARCH DESIGN 1

 Introduction.....1

 Background.....2

 The Site of Chavín: Location and Architecture2

 Chavín’s Place in Andean Prehistory: The Chavín Horizon and Site Chronology.....4

 Site Construction Sequence: Evidence of Construction Phases.....6

 Review of work relating architecture sequence to other sequences.....8

 New Research at the Monumental Center at Chavín de Huántar.....10

 Research Design.....11

 The Research Process11

 The Research Questions.....12

2. METHODOLOGY: MAPPING AND ANALYZING ARCHITECTURE IN THREE-
DIMENSIONS 14

 Fieldwork Methodology.....14

 Mapping Internal Spaces and Exterior Features14

 Visual Documentation of the Architecture17

 Data Overview17

 Analysis Methodology18

 Creation of tools18

| | |
|---|-----|
| Analysis Methodology | 20 |
| Significance..... | 23 |
| 3. LEVEL 1 ANALYSIS: INDIVIDUAL GALLERY CONSTRUCTION EPISODES | 25 |
| Issues in Determining Gallery Construction Episodes..... | 25 |
| Internal seams as data; deciphering their chronological implications..... | 26 |
| Gallery stonework as chronological data | 27 |
| Architectural design principles and the construction sequence..... | 30 |
| Construction Analysis of Individual Galleries | 31 |
| The Escalinata Staircase | 31 |
| The Alacenas Gallery | 40 |
| The East Face Gallery..... | 43 |
| The Zanja Gallery | 46 |
| The Laberintos Gallery and The Pasos Perdidos Gallery | 47 |
| The Lanzón Gallery | 57 |
| Gallery VIII | 65 |
| The Mirador Gallery and The Loco Gallery..... | 66 |
| The Marino Gonzáles Staircase | 77 |
| The Murciélagos Gallery | 78 |
| The Cautivos Gallery..... | 79 |
| Gallery XIII | 81 |
| The Liticos Gallery..... | 82 |
| The Columnas-Vigas Gallery | 85 |
| The Portada Gallery..... | 91 |
| The Doble Ménsula Gallery..... | 95 |
| The Caño Gallery..... | 99 |
| The Caracolas Gallery | 100 |
| The Ofrendas Gallery | 100 |
| The Campamento Gallery | 101 |

| | |
|---|------------|
| The Cortada Gallery | 101 |
| The Escondida Gallery..... | 102 |
| The Tello High Gallery..... | 103 |
| The Tello Low Gallery | 103 |
| Conclusions regarding gallery construction episodes and construction principles | 103 |
| Gallery Seams and Episodes..... | 103 |
| Construction Principles..... | 104 |
| 4. LEVELS 2-3 ANALYSIS: SPATIAL RELATIONSHIPS BETWEEN INTERNAL AND EXTERNAL ARCHITECTURE | 106 |
| Issues in Studying Spatial Relationships at Chavín | 106 |
| Horizontal seams | 106 |
| The Ventilation System | 107 |
| The drainage system within Building A | 108 |
| Dealing with architectural complexity at Chavín: methodological issues | 109 |
| Spatial Relationships within Building A – Northeast corner of Building A (NEA)..... | 110 |
| Delineation of area..... | 110 |
| NEA Gallery-to-Gallery relationships | 111 |
| NEA Galleries-to-Exterior Relationships | 112 |
| NEA Stonework and the Coarse-to-Fine Transition | 113 |
| NEA spatial relationships relevant to construction sequence | 116 |
| Construction of the NEA | 117 |
| Implications | 118 |
| Building A – Northwest corner (NWA) and middle section (MA)..... | 119 |
| Delineation of the NWA area | 119 |
| NWA Gallery-to-Gallery Relationships | 120 |
| NWA Gallery-to-Exterior Relationships | 123 |
| Construction of NWA-MA area..... | 127 |
| Implications | 130 |

| | |
|--|-----|
| NEA-NWA-MA relationships | 131 |
| SA- South end of Building A | 132 |
| SA Gallery-to-Gallery Analysis..... | 133 |
| SA Gallery-to-Exterior Analysis..... | 134 |
| Construction of the SA | 140 |
| Relationships within Building A..... | 141 |
| The ventilation system and its chronological implications | 141 |
| Chronology of MA-SA | 144 |
| Columnas-Vigas | 145 |
| Pegs and external alignments..... | 146 |
| Tenon head course –relationships externally and internally in Building A | 146 |
| Architectural alignment variability within Building A | 148 |
| Building A Chronology Summary | 148 |
| Building B..... | 151 |
| Delimitation | 151 |
| Building B Gallery-to-Gallery Analyses..... | 151 |
| Building B Gallery-to-Exterior Analyses | 154 |
| Building B construction sequence | 158 |
| Building C..... | 160 |
| Building C Gallery-to-Gallery Relationships | 160 |
| Building C Gallery-to-Exterior Relationships | 161 |
| Building C Construction Sequence..... | 163 |
| Circular Plaza Atrium | 164 |
| Gallery-to-Gallery Relationships within the Circular Plaza Atrium..... | 164 |
| Gallery-to-exterior relationships within the Circular Plaza Atrium..... | 165 |
| Relationship between the Circular Plaza Terrace and Escalinata | 166 |
| Circular Plaza Staircase – chronological relationships | 167 |
| Summary of Circular Plaza Atrium Construction..... | 168 |

| | |
|---|------------|
| Building D..... | 169 |
| Building E | 169 |
| Building E Gallery-to-Gallery Relationships..... | 170 |
| External Evidence of Construction | 170 |
| Building E Gallery-to-Exterior Relationships..... | 171 |
| Summary of Construction History of Building E | 172 |
| Summary - Levels 2-3 Analyses | 173 |
| 5. LEVEL 4 ANALYSIS: SITE-WIDE SPATIAL AND CHRONOLOGICAL | |
| RELATIONSHIPS..... | 175 |
| Staircases in Buildings A, B, and C | 175 |
| Covered Staircases..... | 176 |
| Symmetrical Staircases and Construction..... | 177 |
| Construction Sequence of the East Area | 180 |
| The Plaza Menor Terrace..... | 181 |
| The Plaza Mayor and Plaza Mayor Terrace..... | 183 |
| Building E and Building F | 184 |
| The Middendorf Staircase and Building F..... | 185 |
| Building D | 185 |
| Building G and the Bennett "Cells" | 186 |
| East Area Chronology..... | 187 |
| Chronological Relationship between East Area and Buildings A, B, and C and the CPA..... | 188 |
| Relationship of East Face of Building A to East Area..... | 188 |
| Relationships between the East Area and Building B, Building C, and the Circular Plaza | |
| Atrium..... | 191 |
| Site-wide construction and the geologic setting..... | 192 |
| Construction of Buildings NWA-B-C: 2000 Excavation Proposals and Results | 192 |
| Summary..... | 194 |
| 6. SITE CONSTRUCTION SEQUENCE AND GALLERY STANDARDIZATION | 195 |

| | |
|--|------------|
| Chronological Narrative of the Construction of Isolated Phases, Including Galleries, by Area ... | 195 |
| Building A | 196 |
| Building B and the Circular Plaza Atrium | 199 |
| Building C..... | 201 |
| East Area..... | 202 |
| Chronological links between areas | 204 |
| Patterns Within the Gallery Sequence: Gallery Standardization..... | 205 |
| Final Construction Sequence..... | 214 |
| Evaluation of Construction Stages based on Gallery Standardization..... | 214 |
| Discussion of Site-Wide Construction Sequence..... | 215 |
| 7. INTERPRETATIONS AND IMPLICATIONS OF THE CHAVIN ARCHITECTURAL | |
| SEQUENCE..... | 217 |
| Summary and Terminology of the Architectural Sequence | 217 |
| Architectural Patterns and Interpretations..... | 218 |
| High-Level Architectural Principles: What are the architectural principles at Chavín and | |
| how do they inform the construction sequence? | 218 |
| How does the architecture at Chavín change over time? What are the implications of | |
| these changes for site use and labor investment over time?..... | 222 |
| Architectural Forms and Chronology | 226 |
| What does the sequence suggest about Chavín ideology and how it may have changed | |
| over time? | 231 |
| Comparison of the Construction Sequence to Other Sequences for Chavín | 237 |
| Towards an absolute chronology for Chavín architecture: comparisons of the architectural | |
| sequence to radiocarbon dates from the monumental center | 237 |
| Relationships of the architectural sequence to the ceramic sequence | 242 |
| Relationships of the architectural sequence to the art sequence | 243 |
| Relationships of the architectural sequence to surrounding occupations..... | 247 |

| | |
|---|-----|
| Implications for understanding Chavín, its relationships with other sites, and the Chavín horizon | |
| | 250 |
| Changes at Chavín | 250 |
| Relationships with other sites, chronology, and causes of decline | 251 |
| Implications for interpretation and reevaluation of the Chavín horizon | 254 |
| 8. CONCLUSIONS..... | 256 |
| APPENDIX A. ILLUSTRATIONS..... | 262 |
| APPENDIX B. TABLES | 302 |
| BIBLIOGRAPHY | 313 |

LIST OF TABLES

| Table | | Page |
|-------|--|------|
| 5.1. | Centered staircases and doorways | 303 |
| 5.2. | Symmetrical staircases | 304 |
| 6.1. | Initial construction sequence | 305 |
| 6.2. | Initial gallery sequence | 306 |
| 6.3. | Final gallery sequence | 307 |
| 6.4. | Construction sequence for the monumental center at Chavín de Huántar | 308 |
| 7.1. | Radiocarbon dates associated with monumental architecture at Chavín de Huántar, Peru | 309 |
| 7.2. | Summary of revised construction sequence and associated radiocarbon dates | 310 |
| 7.3. | Sequence comparison based on the three-phase construction sequence by Rowe (1967) | 311 |
| 7.4. | Sequence comparison based on revised architectural sequence | 312 |

LIST OF ILLUSTRATIONS

The following illustrations are included in Appendix A and are designated within the text with “-A” following the figure numbers. These, as well as the remainder of the figures which are referenced by the figure number only, are available in digital format. Please refer to <http://www.kembel.com/silvia/chavin> or <mailto:srkembel@stanfordalumni.org> to access or request the illustrations in digital format.

| Figure | Page |
|---|------|
| 1.3. Map of external architecture at the monumental center of Chavín de Huántar..... | 263 |
| 1.4. Plan of the ruins of the temple of Chavín (Rowe 1967:Figure 2). Depicts a three-phase construction sequence for Chavín, with Old Temple and New Temple designations..... | 264 |
| 2.11. Map of gallery locations in Buildings A, B, C, and the Circular Plaza Atrium. | 265 |
| 2.12. Mapped galleries in Buildings D and E..... | 266 |
| 3.418. Carving of intertwined snakes located in the west wall of the Upper Portada staircase. | 267 |
| 4.2. Plan and Architectural North (A) and West (B) views of Buildings A, B, C, and the Circular Plaza Atrium..... | 268 |
| 4.5. NEA (Northeast corner of Building A) area and galleries..... | 269 |
| 4.6. NEA area -- Spatial relationships of internal and external architecture. | 270 |
| 4.28. NWA (Northwest corner of Building A) area and galleries. | 271 |
| 4.29. MA (middle area of Building A) area and galleries. | 272 |
| 4.30. NWA area -- Spatial relationships of internal and external architecture. | 273 |

| | | |
|--------|--|-----|
| 4.31. | MA area -- Spatial relationships of internal and external architecture. | 274 |
| 4.32. | MA area with Columnas Patio -- Spatial relationships of internal and external architecture. | 275 |
| 4.48. | SA (South area of Building A) area and galleries. | 276 |
| 4.50. | SA area -- Spatial relationships of internal and external architecture. | 277 |
| 4.75. | Building A Construction Phase 1: NEA Phase. | 278 |
| 4.76. | Building A Construction Phase 2: NWA-High NWA-MA-SA Platform Phase. | 279 |
| 4.77. | Building A Construction Phase 3: High NEA Phase. | 280 |
| 4.78. | Building A Construction Phase 4: SA Phase. | 281 |
| 4.79. | Building A Construction Phase 5: High MA Phase. | 282 |
| 4.80. | Building A Construction Phase 6: High SA Phase. | 283 |
| 4.81. | Building A Construction Phase 7: Late Building A Phase (Building A Black and White Axis Phase). | 284 |
| 4.82. | Building A Construction Phases: Full Sequence. | 285 |
| 4.85. | Building B area and galleries. | 286 |
| 4.86. | B area -- Spatial relationships of internal and external architecture. | 287 |
| 4.93. | Building B Construction Phase 1: B Platform-ILR Phase. | 288 |
| 4.94. | Building B Construction Phase 2: WB-MB Phase. | 289 |
| 4.95. | Building B Construction Phase 3: EB-High B Phase. | 290 |
| 4.96. | Building B Construction Phases: Full Sequence. | 291 |
| 4.97. | Building C area and galleries. | 292 |
| 4.125. | Circular Plaza Atrium (CPA) area and galleries. | 293 |
| 4.126. | Circular Plaza Terrace blocks the entrance to Escalinata (Esc). | 294 |
| 4.131. | EB-High B-CPA Phase. | 295 |

| | | |
|-------|---|-----|
| 5.35. | Centeredness and symmetry of staircases and architectural features within East Face of Building A. | 296 |
| 6.12. | Standardization of gallery episode forms, by construction stage. . | 297 |
| 6.26. | Architectural relationships between phases grouped within the Black & White Stage. | 298 |
| 7.1. | Phases in the Expansion Stage, with galleries and alignments of select architectural features. | 299 |
| 7.2. | Phases in the Expansion Stage, with galleries and alignments of select architectural features. Detail view of Figure 7.1 view (B). | 300 |
| 7.3. | Phases in the Expansion Stage, with galleries and alignments of select architectural features. Detail view of Figure 7.1 view (A). | 301 |

CHAPTER 1

INTRODUCTION, BACKGROUND, AND RESEARCH DESIGN

Introduction

The monumental center of Chavín de Huántar, located in the highlands of Perú, has attracted much attention from archaeologists since the early part of the twentieth century. Originally expounded as the “Mother Culture” or origin of Andean civilization by Julio Tello (1943, 1960), Chavín later was shown to have been preceded by a long sequence of coastal and highland monumental centers (summarized by Moseley 1985). Chavín was then postulated not only to have appeared late in this sequence, but to have reached its peak in regional influence only after many coastal centers containing art and architectural forms similar to Chavín had declined by the fifth or fourth centuries B.C. (Burger 1981). Central to the issue of Chavín's chronology is the architecture of Chavín itself. The site consists of large platform mounds, terraces, and sunken plazas, permeated by a labyrinthine network of internal galleries. Understanding how and when the site was built and grew is fundamental to understanding Chavín, its chronology, and its relationships with other sites in the north-central Andes.

Key among early studies of Chavín architecture was the three-phase construction sequence proposed by John Rowe (1967), based on construction seams evident in external walls at the site. This sequence was widely accepted, forming the basis for subsequent studies that linked the architecture to ceramic sequences and radiocarbon dates for the site and surrounding area (Burger 1981, 1984, 1988, 1992, 1993; Lumbreras 1977, 1989, 1993). The architecture at Chavín, however, contains more chronological evidence than is incorporated into Rowe's sequence. Numerous internal construction seams and other gallery evidence, as well as new

external seam data revealed by John Rick (Rick et al.1998), clearly indicate that the architectural sequence at Chavín is more complex than archaeologists previously believed.

The primary objective of my research has been to develop a more accurate understanding of how and when the monumental center at Chavín developed by determining and analyzing its construction sequence. Results provide a new understanding of construction principles that guided Chavín's growth, architectural forms incorporated at Chavín over time, as well as a clearer comprehension of the process of Chavín's architectural growth. They hold significant implications for understanding and rethinking Chavín's relationships with other central Andean sites of the Initial Period (1800-900 B.C.) and the Early Horizon (900-200 B.C.).

Background

The Site of Chavín: Location and Architecture

Located in a narrow highland valley (Figure 1.1) in the north-central Peruvian Andes, Chavín de Huántar lies at an elevation of 3,150 m. The temple buildings (Figure 1.2) sit near the point where the Rio Huachecsa flows into the Rio Mosna, a tributary of the Rio Marañon and part of the greater Amazon basin drainage system. Now, as in the prehistoric past, the site is difficult to reach: from the western desert coast, one must cross the mountain ranges of both the Cordillera Negra and the Cordillera Blanca, whose peaks exceed 5,700 m, while from the eastern jungle one must cross the Cordillera Oriental or follow the strenuous, indirect path up the river drainage from the Amazon.

The primary constructions at the site are platform mounds, called buildings, connected by raised terraces, sunken plazas, and staircases that span the various levels (Figure 1.3-A). The external walls of the buildings are constructed of large stones laid in regular courses and set with mud and chinking stones. Thick courses, designated as "A" courses, alternate with thin or "B" courses, creating different patterns of AB and ABB coursing across the facades. Both coarse and

fine stonework is present, at different elevations of the walls. Decorative features, called the tenon-head course and the cornice course, sit near the present highest reaches of the largest building, Building A.

Within these buildings, terraces, and plazas lies the gallery system, a network of passageways, rooms, staircases, ventilation shafts, and drainage canals built within the temple buildings and terraces. I refer to this network in general as “internal architecture.” The construction of the gallery walls consists of courses of typically coarse, rectangular stones in a matrix of mud and small chinking stones. The ceilings of the galleries are built with large stone slabs that span the passageways or rooms below, sometimes supported by corbels. Numerous architectural features are present in the galleries, such as vents, niches, and pegs. The vents connect individual gallery segments to other segments in the same gallery, to other galleries, or to the exterior. The area between the galleries and the external walls of the buildings is solid, filled with small stones and mud, often in orderly fill.

The site has suffered much post-Chavín-period destruction and modification. For example, post-Chavín populations occupied the temple buildings, leaving accumulated layers of structures on top of the buildings and within some of the galleries. Large historic-period incursions destroyed major portions of Building A, leaving large trenches across its east face. Stones have been removed piecemeal from the temple to construct buildings in the surrounding area. Parts of the site were used as agricultural and grazing land well into the 20th century, with some of the galleries serving as livestock corrals. In 1945 a major aluvi3n, or landslide, scoured the top portions of the temple, burying the site and completely filling most of the galleries with mud and rubble. In the decades that followed, significant efforts led by the site caretaker, the late Sr. Marino Gonz3les, cleared aluvi3n mud from many of the structures and galleries, enabling, among other things, the present study.

Chavín's Place in Andean Prehistory: The Chavín Horizon and Site Chronology

The site of Chavín de Huántar has been central to archaeologists' study of Andean prehistory and early complex societies in the Andes. Tello (1960) proposed that Chavín was the origin of Andean civilization, the mother culture from which widespread similarities in art, ceramics, and architecture had spread across the Andes in a "Chavín horizon." Subsequent work demonstrated that Chavín was preceded by a long sequence of early monumental centers in the Preceramic and Initial Periods, many of which incorporated the art, ceramic, and architectural features that Tello postulated originated at Chavín (Moseley 1985).

These early monumental centers were characterized by striking variability in social organization. Moseley (1975) drew attention to this variability, arguing that maritime resources supported the earliest complex societies and monumental architecture on the Peruvian coast before the adoption of agriculture and pottery. Scholars believe that an exchange system for necessary nutrients between the maritime coastal economy and its highland agricultural counterpart furthered development of social complexity in both regions during the Preceramic Period (Moseley 1985; Burger 1985). Monumental centers continued to develop through the Initial Period (1800-900 B.C.) and into the Early Horizon (900-200 B.C.). By the mid-Early Horizon, many coastal centers had gone into decline, collapsing by around fifth or fourth centuries B.C. (Burger 1981; Moseley 1992).

Based on a comparison of radiocarbon dates gathered in and around the temple at Chavín to a set of radiocarbon dates from sites on the coast, Burger (1981) postulated that construction at Chavín began around 800 B.C. and reached its peak only after the centers on the coast had declined. He proposed that the broadly used term "Chavín horizon" be delimited to describe the period when an integrated exchange system, a specific set of ceramic attributes, and technological innovations in metallurgy and textiles became widespread across the Andes, between 490-200 B.C. (Burger 1988, 1993). These broadly similar cultural characteristics appeared nearly

simultaneously over a wide geographic range, extending from the region of Ica, Huancavelica, and Ayacucho in the south, to Pacopampa and the Lambayeque-La Leche valleys in the north, spanning the Andes from the western coast to the eastern slopes leading to the jungle (Burger 1988:137, 1992:216-219). He hypothesized that this spread of characteristics corresponded with the peak of construction at Chavín and thus the peak in influence of a “Chavín cult.”

Debate exists, however, regarding Chavín's chronology, both internally and with respect to other sites. Disagreements revolve around a number of issues: the interpretation of radiocarbon dates that differ from the stratigraphic positions of their samples; split samples returning dates separated by more than 300 years; a set of samples taken from bones possibly contaminated by carbonates from the temple limestone and thus producing the earliest dates for the site; a handful of samples with no provenience; and questionable selection of the most “representative” dates (Burger 1981,1984:277-281; Lumbreras 1989:106-114). Arguing that Chavín was a relatively late phenomenon, Burger proposes a three-phase chronology based on ceramics and radiocarbon dates: Urabarriu, 850-460 B.C.; Chakinani, 460-390 B.C; and Janabarriu, 390-200 B.C. (Burger 1984:277). Arguing that Chavín had earlier beginnings, Lumbreras proposes a four-phase chronology also based on ceramics and radiocarbon dates: Urabarriu, 1200-800 B.C.; Ofrendas, 800-600 B.C.; Chakinani, 600-400 B.C.; and Rocas or Janabarriu, 400-200 B.C. (Lumbreras 1989:186).

These debates over Chavín's chronology need to be resolved in order to clearly understand Chavín's role as a highland religious site within the late Initial Period and Early Horizon. An important step towards this end involves resolving Chavín's architectural sequence and fixing it in time. This dissertation contributes to this resolution by determining the site's architectural sequence and beginning to establish its absolute chronology.

Site Construction Sequence: Evidence of Construction Phases

Seams and other architectural features at Chavín contain important information regarding the site's construction sequence. Construction seams are the primary key to understanding the site's architectural sequence. Seams exist in both the external architecture and the galleries. Many are evident only in the galleries because the corresponding exterior stonework, where originally the seams likely continued, is missing, buried by fill, or covered by later constructions. In addition to seams, the galleries contain other features that can inform the construction sequence. The construction of the temple is characterized by both vertical and horizontal growth, and the locations and elevations of the galleries, their interconnectedness, their stonework characteristics and coursing patterns, evidence of modification, and the identification of construction principles all provide insight into the Chavín's architectural history.

Early studies of Chavín have consistently recognized seams as a key to understanding the site's construction sequence. These studies have approached the site's construction sequence primarily in terms of data gathered from seams on the exterior of the temple. Because these studies have not used the galleries as a key source of chronological data, the wealth of evidence the galleries contain regarding construction phases has not been integrated into an understanding of the construction sequence or related analyses. Previous work on the construction sequence has utilized primarily plan views. The spatial complexity of the interior and exterior seams can be studied most effectively with accurate three-dimensional mapping and analysis of the site architecture, as discussed in the chapter that follows.

Multiple archaeologists have addressed the question of how the monumental center at Chavín was constructed. Archaeologists such as Tello (1960:121), Chávez Ballón (1960:17-19), Rowe (1962:9), Lumbreras (1974b:60), and Burger (1992:130) have suggested that the seams on the exterior of the temple buildings at Chavín mark junctions between construction phases separated by significant lengths of time. These discussions focused on the analysis of seams in the

exterior architecture, although some interior seams were recognized. Kaufmann Doig (1993:36-39), on the other hand, argues that the whole temple complex was planned and built in one phase. He argues that the seams evident on the east and west sides of the temple are a result of various building techniques used simultaneously rather than markers of different construction phases. Pozorski and Pozorski (1987:39-41) do not recognize the seams at all and claim the temple buildings were constructed in a single episode.

Characteristics of Chavín architecture demonstrate that the seams in the temple do indeed mark distinct building phases separated by significant lengths of time. Many seams show clear evidence of being created by abutment; in these cases differences in the construction technique, materials, and alignment of courses between the two sides of a seam suggesting a significant time depth separates their construction. Batter, the inward leaning of external walls, is evident in some seams, suggesting those seams mark former external walls rather than differences in building technique. Wall plaster is visible in two internal seams, suggesting in both cases that a new wall was built directly up against an earlier plastered wall. These internal seams are evidence that the complex was built in a number of different phases, likely separated by significant spans of time, rather than as a single building project.

Rowe (1962:9) recognized seams across the east and west faces of the temple complex and was the first to develop a construction sequence for the site. He modified this original four-phase sequence a few years later into a simpler three-stage sequence (Figure 1.4-A). He proposed an original U-shaped “Old Temple” oriented towards the east with flanking north and south wings. This Old Temple was followed by the construction of the “New Temple”, consisting of two slab additions to the south and a set of structures extending east, including a large rectangular sunken plaza flanked by two mounds to the north and south, forming a U with the slab additions and the south wing of the Old Temple. Rowe’s three-phase sequence has been widely adopted and is the standard model presented in works on Chavín (Burger 1984:229-246; Burger 1995:131; Lumbreras and Amat 1965-1966; Lumbreras 1971:2; Lumbreras 1989), Andean

prehistory (Lumbreras 1974b:60; Moseley 1992:155; Moore 1996:51-52; Isbell 1976:289), general archaeology (Renfrew & Bahn 1991:360-361), and art history (Kubler 1975:254; Stone-Miller 1995:39).

Review of work relating architecture sequence to other sequences

Studies of other aspects of Chavín have used Rowe's construction sequence as a foundation. In particular, key studies have attempted to establish links between the architecture and relative sequences of other aspects of Chavín material culture. This work and the critical links that have been proposed are addressed here.

Art

Rowe's iconographic seriation (1962, 1967) details the stylistic change between the various sculptures associated with the Old Temple and the New Temple. Based on his architectural sequence, this seriation is anchored to two points in the architecture. The primary anchor point for the sequence, located on the east face of Building A, is the sculptures of the Black and White Portal, comprised of the two feline-avian figures on the columns and the avian figures on the lintel spanning them. These are defined by Rowe as Phase D. Phase AB is also anchored in the architecture. It includes the Lanzón monolith from the Lanzón Gallery as well as feline cornice blocks from Building A, such as the one currently in place on the west face of its southwest corner (Rowe 1962:12).

Ceramics

Lumbreras's excavations in the atrium of the Old Temple (the Circular Plaza Atrium) revealed the Circular Plaza and galleries, including the Ofrendas Gallery, constructed in a terrace surrounding the plaza (Lumbreras 1977, 1993). Based on its location within U-shaped arms of

what Rowe had concluded was the Old Temple, Lumbreras (1977, 1993) concluded that the Circular Plaza Atrium belonged to the Old Temple, and that therefore that the Ofrendas Gallery and the ceramics found in it did as well. The ceramics from the Ofrendas Gallery are the ceramics most directly and clearly associated with an architectural phase. Lumbreras postulates a relationship between his ceramic phases and Rowe's architectural sequence, associating the Old Temple with the Urabarriu (1200-800 B.C.) and Ofrendas (800-600 B.C.) phases of his chronology, and the New Temple with the Chakinani (600-400 B.C.) and Rocas-Janabarriu (400-200 B.C.) phases (Lumbreras 1989:23, 186).

Burger (1981, 1984) created a three-phase ceramic sequence based on his excavations outside the monumental center and surface collection in the monumental center and the surrounding area. Burger also has postulated a relationship between his ceramic sequence and the earlier three-phase architectural sequence outlined by Rowe (1967), proposing that the first building phase corresponds with the Urabarriu phase of his chronology (850-460 B.C.), the first addition with the Chakinani phase (460-390 B.C.), and the second addition with the Janabarriu phase (390-200 B.C.) (Burger 1984:229-245; 1995:165). Burger states that the "Urabarriu ceramics pre-date or are contemporary with the earliest pottery of the Ofrendas Gallery (Burger 1984:230).

Radiocarbon

Radiocarbon samples from the Ofrendas Gallery deposit returned uncalibrated dates of 1100 B.C. and 750 B.C. (Lumbreras 1993). Due to the location of the Ofrendas Gallery within the Circular Plaza Atrium, it was concluded to have been constructed with the Old Temple (Lumbreras 1977). These dates therefore were viewed as a chronological frame of reference for the Old Temple and the earliest constructions at Chavín (Lumbreras 1977; Burger 1981, 1984). These dates are widely viewed as the primary published Chavín-period dates from reliable contexts at the monumental center (Burger 1981; Lumbreras 1993).

New Research at the Monumental Center at Chavín de Huántar

In the summers of 1995, 1996, and 1998, Rick led an extensive mapping project of the Chavín temple complex and surrounding areas using total station surveying technology, to study the site's architecture (Rick et al. 1998). Work also involved strategic excavations at architectural seams to reveal details of the site's construction. A separate system for mapping the galleries at Chavín was developed by my team as a subset of the greater mapping project, as described in the following chapter.

Excavations at Seams

Strategic excavations by Rick in 1996 and 1998 have revealed critical information regarding the exterior seams at Chavín (see 1.3-A above for locations of exterior seams). Excavations revealed a seam on the north face of Building A, referred to here as seam A-N-1. (External seams are referenced by describing the building and face in which they sit, and the specific number for that seam on that face. For example, A-N-1 stands for Building A-North face-Seam #1). The north seam on the east face, A-E-1, was found to extend to the foundations of Building A. Together these two seams demonstrate that an early building forms the northeast corner of Building A; this building is called the NEA (northeast corner of A) (Rick et al. 1998). Opposite A-E-1, on the west face, no seam was found; this contradicts the placement of a postulated seam here by Rowe (1962, 1967). The south seams on the east (A-E-2) and west (A-W-1) faces align with each other along a plane, indicating they mark opposite ends of the same seam, and terminate in a low platform that extends south under the south portion of Building A. Additional seams were not found on the west wall of the temple, opposite the north wall of Building A and the south wall of Building C (Rick et al. 1998). Documentation of the forms and

locations of these seams enables precise analyses of how the exterior seams compare with the internal seams in the galleries, as described below.

Radiocarbon samples collected from these excavations were corrected for 13/12 C fractionation, but the dates were not calibrated. The limitations of the calibration curve for the middle of the first millennium B.C. are recognized and raise significant issues regarding the reliability of dates from this time period; however, they do not appear to reverse the major trends seen in the radiocarbon dates discussed in Chapter 7.

Research Design

The Research Process

Determining a more accurate site construction sequence is an important step towards resolving Chavín chronology. The buildings at Chavín provide a rich source of data about the site's construction; the numerous internal seams present in the galleries as well as the new external seam data revealed by Rick et al. (1998) clearly show that the architectural sequence at Chavín is much more complex than archaeologists previously believed. In the light of new, three-dimensional measurement data, I reevaluate Chavín's architectural sequence in order to develop a more accurate understanding of how Chavín's architecture grew and changed.

After proposing a relative construction sequence based on precise three-dimensional data, I anchor the sequence in time to suggest an absolute chronology for Chavín's temple complex. I compare Chavín's sequence with published radiocarbon dates for the site (Burger 1981; Lumbreras 1993), and with dates from radiocarbon samples collected in Rick's strategic excavations at the site (Rick et al. 1998; Rick and Kembel 2000). Because studies regarding Chavín and its place in Andean prehistory have built upon Rowe's construction sequence, I evaluate sequences developed for ceramics (Burger 1984; Lumbreras 1989), art style (Rowe 1962, 1967), and occupation patterns (Burger 1981, 1984) at the site in the light of this newly

proposed construction sequence. Absolute dates for a number of the phases fix the relative chronology in time and test hypotheses proposed by Burger and Lumbreras that link ceramic and art phases to the architectural phases. I conclude by examining the implications of this sequence for better understanding Chavín, its relationships with other sites, and its place within Andean prehistory. The results of these analyses help clarify our understanding of the site of Chavín and its relationships with other Initial Period and Early Horizon sites.

The Research Questions

This dissertation addresses a set of primary questions regarding the architecture of the monumental center at Chavín and its construction sequence.

1. What are the architectural principles at Chavín and how do they inform the construction sequence? Determining the construction principles employed at Chavín, as well as how they changed as the temple grew, can help elucidate growth patterns and the construction sequence.
2. How does the architecture at Chavín change over time? What are the implications of these changes for site use and labor investment over time?
3. Chavín is viewed by scholars as a combination of the U-shaped platform, which originated in the central coast, and the circular plaza, which originated on the north coast (Williams 1980, 1985; Moseley 1985; Burger 1985). Architect Carlos Williams states,

Whether both the circular pit and the U-shaped pyramid arrived together at Chavín or were successive importations remains an unsolved problem. A better analysis of the architectural structure of the temple and absolute dating of its different stages of construction would help to solve this problem. (Williams 1985:238)

Building on the ideas of these scholars, a set of questions regarding architectural forms and chronology follows:

a. When were the Circular Plaza and the U-shaped form incorporated into Chavín architecture?

b. Are other forms present as well, and if so, what are they? Do they indicate coastal antecedents and influences, highland antecedents and influences, or innovations specific to Chavín? When are these other forms introduced?

c. What aspects of Chavín architecture are unique to Chavín? Do these aspects change over time?

4. What does the sequence suggest about Chavín ideology and how it may have changed over time?
5. How does the architectural sequence of the monumental center compare with the site's radiocarbon dates, ceramic sequences, art style sequence, and patterns of population settlement and growth?

Finally, this dissertation considers the answers to these questions and the results of these comparisons together, to address their implications for understanding the site of Chavín, its relationships with other sites, and its place within Andean prehistory.

CHAPTER 2

METHODOLOGY: MAPPING AND ANALYZING ARCHITECTURE IN THREE-DIMENSIONS

As outlined in the previous chapter, a full investigation of Chavin's construction sequence required mapping the site's internal architectural spaces three dimensionally, linking the resulting data to external architectural data, and analyzing them together in three dimensions. In response to this challenge, my team and I developed equipment and methods for collecting three-dimensional data in interior spaces as well as tools and methods with which to analyze that data. This process, along with an overview of the resulting data, is outlined below.

Fieldwork Methodology

Mapping Internal Spaces and Exterior Features

Prior to our investigation of the site, archaeologists had created a number of maps of the galleries, attempting to document their locations within the temple buildings (Roosevelt 1935:Fig. 23; Tello 1960:Fig. 9, Fig. 10; Lumbreras and Amat 1965-1966:Planos II-IV; Lumbreras 1971:Fig. 2; Kauffmann Doig and Gonzales Moreno 1993:Fig. 18, Plano 14). They were unable, however, to map them precisely due to technological and methodological limitations in mapping internal spaces separated by unknown distances. This inherent difficulty in locating the galleries accurately in space caused the horizontal locations of the galleries in the resulting plan-view maps to vary, along with their shapes, sizes, and orientations. The galleries' elevations within the buildings were not documented, nor were their exact locations and orientations relative to each

other and to external architectural features including seams. The presence and locations of internal construction seams also were not documented.

To surmount the difficulties encountered by past researchers, my team and I developed new technology and a new methodology for collecting three-dimensional data in interior spaces. We designed a laser-based system for accurately mapping interior architectural spaces, and in 1996 began establishing the absolute position of each gallery within the site. We returned to Chavín in 1998 with a refined version of this system to complete the mapping project of the galleries and important exterior features, as well as to collect other architectural data.

The key to this new internal mapping system is a visible-laser technology that enables distances to be measured in small interior spaces without the cumbersome optics and reflector rod of standard surveying equipment. In the 1996 field season, we used leveled, orthogonal laser lines to form the axes of local coordinate systems in the galleries, creating the foundation of the first version of the gallery mapping system. The Plumb Level Square (PLS), a self-leveling laser-emitting device available commercially, projected orthogonal lasers up, down, left, right, and forward (Rick 1996:8-9). From these laser lines, a set of equipment was used to measure the distance, vertical angle, and horizontal angle for each three-dimensional point collected. This equipment consisted of a Leica Disto (a laser-based hand-held electronic distance measuring device (see Rick 1996:9)), a digital level attached to the Disto, and a jig system designed for the project by one of the team members (Figures 2.1 - 2.3). Three different methods for acquiring data were used, depending on the architectural geometry of the space. The data were recorded by hand into a custom database on laptop computers. Contextual details and notes useful in reconstructing the space were logged simultaneously into a field notebook. Following the 1996 data collection, custom software was developed and used to convert the distance and angle measurements into local x-y-z coordinates for each gallery. Using custom software developed for the project, the points for each gallery then were translated and rotated into the site coordinate

system established by Rick's concurrent total-station mapping project of the topography and exterior architecture of Chavín. This placed each gallery in its absolute position within the site.

We refined aspects of the gallery mapping system in order to streamline the data collection process for the 1998 field season, still incorporating the visible-laser technology. In this system, Leica's DataDisto GSI emits a visible red laser to a desired point, measures the distance to that point, and then transfers the data to an attached total station, an electronic surveying instrument. The total station then reads the horizontal and vertical angles from the origin of the visible laser to the measured point and downloads all the data to a laptop computer, which plots the data real-time on a laptop computer (Figures 2.4 - 2.6). Each three-dimensional point is accurate to +/- 3 mm, and gathered within the site coordinate system. Combined with a customized tripod and a specialized database, both designed and implemented by my team, this new visible laser system enabled us to map the galleries in all their forms, from long passageways and steep staircases to narrow canals and collapsing rooms, tasks that would have been nearly impossible otherwise (Figures 2.7 - 2.9). The combined result from these two field seasons is a highly precise set of data that establishes, for the first time, the form and absolute position of each accessible gallery within the site.

In the galleries we took measurements at points that define the shape and geometries of the gallery, such as along the intersections and midpoints of walls, floors, and ceilings, as well as at architectural features such as seams, niches, vents, and pegs (Figure 2.10). Each three-dimensional point was given a code corresponding to the architectural feature it documented, to facilitate later modeling. These points and associated information document the form and location of the galleries, as well as the architectural details of their internal construction.

We also used the visible laser system to collect spatial data for important exterior architectural features. These include exterior seams, the tenon-head and cornice courses, vent openings, hanging staircases, coursing changes, stone-type changes, and wall perimeters.

Additionally, we collected data to check the locations of the galleries mapped in the 1996 season, to confirm that the systems were consistent, and to link the data sets collected by each.

After our 1998 field season, Leica introduced reflectorless total stations, instruments that combine the visible-laser technology of the DataDisto GSI system with the reflector-based survey technology of traditional total stations. With these innovations in commercially available mapping technology, archaeologists can now map internal architectural spaces more easily than before and with less dependency on custom development.

Visual Documentation of the Architecture

Fieldwork also included visually documenting the architecture. This documentation involved exploring the site in order to locate any galleries, vents, or drainage canals that had not been included in earlier maps; gathering architectural observations by documenting each gallery and portions of the exterior architecture with descriptions and drawings of seams, stone work, and other architectural features; and photographically documenting the architecture in order to facilitate modeling and answering new questions upon the return from the field. We also interviewed the site caretaker, the late Marino Gonzáles, and a site worker, Alejandro Espinoza Noceda, regarding recent modifications to the site and the galleries, to supplement an extensive set of videotaped interviews of Marino Gonzáles by Rosa Mendoza Rick, completed between 1995 and 1998..

Data Overview

During the 1996 and 1998 field seasons my team and I gathered approximately 20,000 three-dimensional points documenting the 26 accessible galleries as well as internal and external seams, and other important external architectural features (Figures 2.11-A, 2.12-A, 2.13 - 2.16).

We documented five galleries unreported in publications, and forty-five interior seams. To facilitate modeling and analysis of the three-dimensional data away from the field, we documented the interior and exterior architecture with architectural drawings and approximately 3000 photographs.

Because published names do not exist for the newly documented galleries, we referred to them with the following names, according to the tradition of using names that describe the location or a characteristic of each gallery. These galleries are: the East Face Gallery (la Galería de la Fachada Este), the Gallery of the Trench (la Galería de la Zanja), the Gallery of the Waterspout (la Galería del Caño), the Tello High Gallery (la Galería Tello Alta), and the Tello Low Gallery (la Galería Tello Baja). To the galleries Tello called Galleries XV and XVI, we added the names the Cut Gallery (La Galería Cortada) and the Hidden Gallery (la Galería Escondida), respectively.

Analysis Methodology

Because the type of spatial data collected by my team was new, I developed new tools and methods to work with and analyze the data.

Creation of tools

Computer Model of Architecture

My primary goal was to use the collected three-dimensional data to model the temple so that I could define precisely how the galleries relate spatially to each other, to seams and other architectural features, and to the temple area as a whole. Using MicroStation, a computer-aided-design (CAD) program, I designed the model structure to allow the user to analyze the spatial data with maximum flexibility. To do so, I developed a hierarchical file structure with three types

of files: point files, surfacing files, and analysis files. Point files form the model's foundation. Individual point files contain the points of a single architectural unit, such as a gallery or an exterior feature (Figure 2.17). Within that file, points of distinct architectural features, such as corners or seams, are imported onto separate viewing levels. These levels can be viewed individually or together in any combination. The point files can then be surfaced or analyzed; in surfacing files they can be fleshed-out to enhance visualization (Figures 2.18, 2.19), while in analysis files they can be measured or analyzed. From a central surfacing or analysis file, any number of point files can be worked with simultaneously or selectively, as can groups of point, modeling, and analysis files. The model can be updated with new data points, modeled surfaces, or analytical features, and any feature or point set can be turned on or off as desired. The model's flexible structure enables the user to explore and analyze any feature or issue of interest.

Detailed analyses, such as measuring features or comparing dimensions, are based on specific data points. Grounding the analyses on individual data points enables the results to be highly accurate. Surfacing, on the other hand, primarily helps the user visualize the architecture in three-dimensions. Surfaced models thus enable the user to understand the spatial relationships between architectural elements. Surfacing an individual gallery involves connecting the color-coded points, defining surfaces of features, and creating and surfacing a triangulated wireframe mesh. Surfacing larger areas of the site follows a similar process, building from the three-dimensional data points.

With this three-dimensional model, I can establish the construction sequence by analyzing how the galleries and interior seams relate to each other and to the exterior architecture and seams. This analysis process is explained below.

Image Database

Approximately 3000 photographs documenting the site architecture were scanned and entered into a searchable image database. The purpose of the database is to provide a searchable,

visual documentation of the galleries and the exterior of the site, in order to facilitate the three-dimensional modeling and analysis of the architecture away from the field. The database is searchable by twenty-three fields, such as Location Within Site and Gallery Segment. It makes an invaluable source of data readily accessible to the researcher.

Other tools

All field notes, architectural analyses, and drawings were copied and compiled into notebooks for ready access during the analysis process. To answer specific questions about the architecture beyond those addressed in my own interviews, videotaped interviews of Marino Gonzáles by Rosa Rick were duplicated and indexed with help from other students. Additionally, radiocarbon samples from the excavations by Rick were dated, in order to begin to establish an absolute chronology for the construction sequence.

Analysis Methodology

My analysis required a process that would enable me to systematically identify and sequence individual construction phases, as well as to infer site planning principles and architectural canons. I therefore developed the following four levels of analysis. While the three-dimensional points, photographs, and drawings can only be gathered on the site, most of the analyses here can only be done in the computer model. Much of the Level 1 analysis can be done on-site, but Levels 2, 3, and 4 are possible exclusively via the computer model.

Level 1- Individual gallery: What are the construction episodes of each gallery?

The first step in deciphering the construction sequence is to determine the number and sequence of construction episodes within each gallery. This involves analyzing the features of a gallery that are relevant to its construction sequence, such as its form, seams, stonework, and

evidence of modification, then forming and testing hypotheses about its construction. In this process the three-dimensional data points are studied along with field notes, photographs, and drawings. Understanding the construction sequence of a gallery requires determining the chronology of each seam in that gallery – that is, which side of the seam was built first. In some cases, this process is straightforward and confirms conclusions drawn in the field. In other cases, where the construction is less clear, the seams are reexamined as site planning and construction principles emerge in the analysis. Additional insight into the construction of a gallery can come from its relationships with other galleries and the temple exterior, as well as how it accords with inferred site planning principles that emerge in higher levels of analysis; the construction sequence of a gallery can be validated by incorporating these relationships. In cases where portions of galleries no longer exist due to erosion, destruction, or collapse, analyses are based on data recorded in earlier accounts. The results of this level of analysis form the foundation for the subsequent higher levels of analysis.

Level 2 - Gallery-to-gallery: How do the galleries relate to each other?

The next level of analysis determines how the gallery construction episodes determined above relate to each other spatially. This process involves using the computer model to systematically study how each gallery's interior features relate to those of other galleries, such as relative gallery elevations, dimensions, and locations; how galleries overlap in plan and elevations; how galleries connect via vents, or stairs; how they relate to internal seams; how internal seams relate to each other; how, if at all, individual construction sequences interlink; and how other elements compare, such as architectural features, form, construction, and stonework. Once established, gallery-to-gallery relationships can indicate building events that extended beyond single gallery modifications or episodes, linking multiple galleries and building areas, and indicating large-scale building phases that affected the galleries. Combined, the individual gallery

sequences and the relationships between galleries are used to begin establishing the relative chronology of the galleries.

Level 3 - Galleries-to-Exterior: How do the galleries relate to the exterior architecture?

The third level of analysis addresses how the galleries relate to exterior features. Do they align with significant exterior coursing changes? Do they align with exterior seams, cornices, staircases, or plazas? These analyses involve studying the relationships, in plan and elevation views, between galleries and features on each external face, comparing their elevations and placement within the temple. They also involve investigating structural connections between interior and exterior, such as vents and staircases. Galleries are analyzed individually and in groups, in order to identify relationships between the internal architecture and exterior features that indicate larger construction phases. Many construction phases can be isolated and sequenced with the combined Levels 2 and 3 analyses.

Level 4 - Site-wide analyses: How do all the above elements fit together, and in what sequence?

Level 4 analysis integrates the results of the first three analysis levels, in order to further isolate phases of construction and determine their chronological sequence. Gallery construction episodes, gallery-to-gallery relationships, and gallery-to-exterior relationships are analyzed within and between large areas of the temple. Construction principles that emerged in previous levels of analysis are analyzed at a site-wide level, helping to clarify how different areas of the temple relate. Resulting hypotheses regarding the construction sequence are used to deduce possible locations of buried external seams for subsequent strategic excavations (such as those by Rick in the 2000 season). Results from these excavations are used to validate and/or refine the sequence hypotheses. With phases isolated and construction principles identified, the site's architectural phases are then sequenced at a site-wide level. Further analysis of gallery construction patterns

within this site-wide sequence enables floating phases to be more precisely anchored within the sequence. The phases of the site sequence are then grouped into higher-level construction stages.

In carrying out these analyses, a distinction is made between isolating construction phases and sequencing them. Isolating a phase involves identifying elements that were built at the same time as a complete unit. Sequencing phases involves determining the chronological relationships between these isolated units. Distinguishing these is essential. For example, the isolation of a phase may be clear but not its place in the sequence, or a feature's relationships to some phases may be clear, but not whether it should be included in a particular phase. Additionally, two isolated phases may clearly come after another phase, but their chronological relationships to each other may not be clear; this is particularly true when phases are not contiguous. By synthesizing the galleries' individual construction episodes and their spatial relationships with each other and the exterior, site-wide construction phases can be isolated and sequenced.

Significance

These methods for gathering, modeling, and analyzing spatial data contribute significantly to archaeology. Archaeologists are now able to do "virtual fieldwork," exploring sites on the computer in order to answer questions that previously could not be answered and to pose new questions that previously could not be conceived. Large sets of precise spatial data for any site with substantial architectural remains can be collected, modeled, and analyzed. Interior spaces such as the galleries at Chavín can be studied more accurately, because the researcher can take points of view that are impossible to access in the field. The model gives archaeologists "x-ray vision" to see through walls into the interior of the structures, to examine the site from any angle, and to take measurements between any points or features and compare their dimensions, their elevations, and their alignments within the site. These methods can be used to test

hypotheses by analyzing existing data, and as a predictive tool to more efficiently direct purposeful excavation in the future. They facilitate single-site studies as well as multi-site comparisons, making possible broad studies of architectural growth and patterning.

CHAPTER 3

LEVEL 1 ANALYSIS: INDIVIDUAL GALLERY CONSTRUCTION EPISODES

The first level of analysis addresses the individual galleries at Chavín and the information they contain regarding the site's construction sequence, as outlined in the previous chapter. The seams, stonework, and layout of each gallery are examined to determine the number and sequence of its construction episodes. Construction episodes are viewed as distinct chronological phases within an individual gallery. The results of this interior analysis of gallery construction episodes provide a foundation for determining the site's construction sequence, and reveal patterns in the design and construction of the galleries.

Figures 2.11-A and 2.12-A show the locations and forms of the galleries, based directly upon the three-dimensional data gathered in the galleries. In the figures that follow, maps of individual galleries are also based directly on the three-dimensional data, and thus appear somewhat irregular due to the existing variation in the gallery walls. Detailed descriptions of the forms and dimensions of many of the galleries are provided in Tello (1960) and Lumbreras and Amat (1965-1966). Specifics regarding gallery forms and dimensions are included here primarily when relevant to determining gallery construction episodes; otherwise, forms and dimensions are presented visually in figures.

Issues in Determining Gallery Construction Episodes

Before examining the construction episodes of each gallery individually, it is helpful to address three issues relevant to the galleries as a group that emerge in the following analyses: the chronology of internal seams, the chronology of internal stonework, and construction principles.

Internal seams as data; deciphering their chronological implications

Forty-five seams were documented inside the galleries. Most of them exist only in the galleries and do not extend to the exterior architecture, a significant factor in determining the construction sequence of the site. Internal seams take two primary forms: end wall seams and wall seams. End wall seams are formed when one wall perpendicularly abuts another. Wall seams lie within a single wall, and are formed when one portion of the wall abuts another. Seams can lie in either a vertical or a horizontal plane. They are usually marked by a straight edge separating the two sides of a seam, as well as by a change in coursing, a change in stonework, and/or, in some cases, a thin band of plaster in the mortar at the plane of abutment.

Determining the chronology of each seam – that is, which side of the seam was built first – is critical to determining the sequence of the galleries' construction episodes. The primary clue in establishing the chronology of most seams is the order of abutment, indicated by the stonework of the two sides of the seam. However, the order of abutment does not indicate the amount of chronological separation marked by the abutment; as Schreiber (1978:62) states, “abutment indicates that one wall was built later than another, although ‘later’ may mean one minute later as easily as one century later.” It is thus necessary to search for other factors that help establish time depth in the construction of a seam and that suggest that the seam marks significantly different building episodes. The primary factors in determining whether a seam marks chronologically distinct constructions, or episodes, are differences in stonework and coursing between the two abutting walls, and the presence of plaster in the plane of abutment. Other factors can include relationships with other galleries or gallery segments that indicate the abutment was separated significantly in time, such as a set of vents blocked by an addition; a functional change in the gallery's form; or construction patterns that suggest abutment may have been used as a construction technique within a single building episode.

Establishing the time depth of a seam also involves determining whether the seam was created during Chavín times or if it was created in a post-Chavín period, either prehistorically or more recently; this is done by examining stonework characteristics, early descriptions and photographs of the galleries, and interviews of Marino Gonzáles and other workers closely involved in the site's maintenance. Many areas in the galleries and across the site have been modified, consolidated, or reconstructed since Chavín times, creating seams and other signs of additions. The primary factors responsible for these changes include prehistoric post-Chavín occupation and modifications to the architecture, and modern efforts to consolidate and reconstruct collapsed or collapsing areas after the 1945 landslide that covered the site and filled the galleries. These efforts were begun by Marino Gonzáles soon after the 1945 landslide and continue today largely through efforts coordinated by the Instituto Nacional de Cultura and UNESCO. Post-Chavín modifications are discussed here only when relevant to understanding the original construction sequence.

Gallery stonework as chronological data

As part of the study of gallery chronology, I investigated whether gallery stonework could be classified according to a limited number of formal types and whether any such formal types would correspond with gallery construction episodes. Observations indicated that gallery stonework is present in a continuum of variables including stone size, regularity of coursing, amount of mortar used between stones, amount of chinking stones, size of chinking stones, and amount and quality of worked stone. Different construction episodes do contain different patterns of stonework, but these patterns do not easily lend themselves to a typology, in large part because the above variables comprising the stonework can vary within individual gallery construction episodes. A complete formal study of possible stonework typology within the galleries was

determined to be outside the scope of this project, but could be a fruitful line of future investigation.

Even without a formal typology, however, differences between stonework in the two sides of a seam can be used to examine the time-depth of that seam. The basic principles are these: if the walls on different sides of a seam are built with different stonework, the seam likely marks a significant chronological gap between their construction. If the stonework on both sides of a seam is very similar, the seam may not represent a significant time gap, and may be an example a construction technique in which abutments or other indicators of seams are created within a single building episode.

As a corollary to this, similar stonework in two non-adjoining areas suggests those areas may have been built in the same episode. Similar stonework likely would be created by builders using the same construction technique with the same quality of building materials. This does not mean that galleries built in the same phase will necessarily have the same stonework; galleries within the same phase could have different stonework, depending on factors including the construction technique used by the builders and the available building materials.

This reasoning is consistent with the fact that some interior surfaces of some of the galleries, such as Escalinata and Lower Loco, are covered with plaster. Plaster in the galleries was noted by Tello (1960), Rowe (ms.a), and Lumbreras and Amat (1969), who all concluded that originally the galleries likely were plastered inside, suggesting that gallery walls, ceilings, niches, staircases – effectively all interior surfaces in the galleries – were covered with plaster. For example, Tello reports that the interior walls frequently are found covered with a layer of clay hardened by fire (Tello 1960:32), stating that

presently the walls of the galleries are found without covering, but it can be supposed that originally they were plastered and perhaps decorated with frescos and polychrome reliefs ... judging by the large quantity of clay that lies on the floors, the remains of red and yellow paint on some of the walls, and the pieces of burnt clay in the rubble of the galleries and the upper buildings of the main temple. (Tello 1960:92; translation mine)

Rowe's report concurs, stating:

The galleries were stuccoed inside. There are bits of mud plaster at least 1 cm thick, fairly commonly in the corners. Some of the fragments were painted white. I saw one which suggested an adobe relief of volutes, but the fragment was small and damaged. The north entrance stairway was all plastered, including walls and steps. Bits of loose plaster are found in most of the galleries with traces of vermilion. One bit of vermilion painted plaster is in situ in the entrance hall of the Lanzón gallery. Bits of plaster painted yellow and white are also found. No black. González has not found traces of plaster on the outer walls. (Rowe ms.a:103)

The report by Lumbreras and Amat is also consistent with this, stating that

according to what can be observed in some galleries, it appears that all of the interior walls were covered by a thick layer of earth that served as plaster, a smooth layer that was covered with paint that could be red, white, or yellowish-cream. (Lumbreras & Amat 1969: 149-150; translation mine)

Additionally, in excavations in the Ofrendas Gallery, they report that a clay layer averaging 10 cm in thickness but ranging between 20 cm and 8 cm

was evidently formed of earth from the disintegration, caused by humidity and other factors, of the surfacing and plaster that all the walls in the gallery contained. In the excavation of some cells it was still possible to observe that the layer of earth that covered the walls was up to 5cm thick. The fallen earth, with the humidity and the pressure, turned in certain areas to blocks of hard clay, while in others where there is still humidity, it appeared with all the plastic and greasy consistency of clay, which made the excavation difficult. (Lumbreras & Amat 1969:167; translation mine)

These statements confirm the present evidence of plaster in the galleries, suggesting that the galleries as a whole were plastered, in colors of white, red, and yellow. Remains of plaster presumably were most visible when Tello visited the site prior to the landslide of 1945 that filled the galleries with mud and rubble. In galleries where the landslide mud was cleared, remains of the mud still cover many of the walls, obscuring plaster that may have remained after the landslide.

The plastering of the gallery walls is an important factor to consider when studying the stonework in the galleries and its chronological implications. It suggests that the stonework of prior gallery construction episodes likely were covered in plaster and not visible to the builders in later episodes, and thus that any hypothetical attempt by builders to match the style of an earlier episode would have been unlikely. Plaster was observed embedded in two seams, in the Lanzón

Gallery and the Columnas-Vigas Gallery, as discussed below; the presence of plaster in these seams suggests that galleries were plastered after each construction episode, rather than all at once.

The lessons taken from the gallery stonework at Chavín are summarized as follows: stonework is not easily categorized as a limited number of formal types; stonework within a given gallery construction episode can vary; stonework that differs between adjoining walls separated by a seam suggests the walls were built at different times; similar stonework between non-adjoining walls suggests these walls could have been built at the same time; and stonework can vary between galleries built in the same phase.

Architectural design principles and the construction sequence

The search for architectural design principles and construction patterns involves observing architectural features that repeat across the site. Once identified, these design principles help determine relationships between different areas, contributing to the construction sequence. For example, one of the most consistent design principles evident at the site is that ceilings over staircases and stepped canals are stepped. This pattern was noted by both Tello (1960) and Rowe (ms.b), and new evidence presented in this chapter supports it as well. When observing the numerous areas with stepped ceilings in which the floors were covered with fill, both Tello and Rowe used this pattern to conclude that a stepped ceiling implied a staircase sat beneath the fill. As floors have since been cleared in galleries including Portada, Liticos, and Laberintos, their observations have proven correct. Accordingly, this design principle can be used to help determine the construction history of some areas, just as other design principles and building patterns observed in this and later chapters can be used in later analyses to study the construction of other areas of the temple.

Additional design principles and construction patterns observed in the following analyses are: many galleries were built in multiple construction episodes; significant modifications were common and occurred in most of the galleries, largely to accommodate additions in new construction episodes; galleries or levels within a gallery connected by stairs were built in different episodes; some external walls were converted to internal walls by the abutment of a gallery against them; galleries were entered from the outside through descending stairs; staircases do not contain corbels; and batter marks tall interior walls as well as tall exterior walls. These principles and patterns are highlighted in the gallery analyses that follow.

Construction Analysis of Individual Galleries

The Escalinata Staircase

The Escalinata Staircase, or la Galería de la Escalinata, is located in the north side of Building A in the NEA, aligned parallel to its north face (Figures 3.1 - 3.4). The entrance lies at the base of the north face of Building A, and presently is largely blocked by debris and constructions in the Circular Plaza Atrium. Inside the entrance lies a double staircase, with one staircase ascending to the east, another to the west. The gallery is filled with much debris and post-Chavín occupations, and its upper portions have eroded and fallen along with the upper surfaces of the temple. It is a prominent gallery, the largest in the NEA.

Escalinata's coherent design and its lack of seams or evidence of significant modifications suggest it was built in one episode as a functional unit (Figure 3.5). It contains innovative architectural elements not seen elsewhere at Chavín, such as a double-staircase ascending from a single entrance staircase, tie beams, and a relieving window.

Tie Beams and Stonework

Two large stone beams span Escalinata mid-height, providing important information regarding the construction of this gallery (Figure 3.6). They lie at approximately the same elevation and the same course. One spans the east staircase, the other the west staircase, and they are symmetrically placed equidistant from the center of the north entrance. These beams tie together the north and south walls of Escalinata, stabilizing and supporting the tall walls and ceiling of the gallery. No other tie beams are found at the Chavín.

The construction of the walls in which the beams are embedded clearly indicates the beams were set in place at the same time that both walls were built. The coursing on both the north and south walls is consistent around the beams, with no evidence of disjunctions or deconstruction. This is most evident on the east beam (Figures 3.7 - 3.10), whose joints with the walls are not partially obscured by later additions, unlike the joints of the beam on the west (Figures 3.11, 3.12). Although the top of the south wall is deteriorating from erosion, its stonework is consistent (Figure 3.13) from top to bottom, as are the remains of the north wall. Taken together, these data indicate the tie beams, south wall, and north wall of Escalinata were built at the same time, which in turn suggests that the steps between the walls were also built in this episode.

Stairway at North Entrance

A 3m-long passageway connects the north face of Building A and the north internal wall of Escalinata. The floor, sides, and entrances to the passageway are presently obscured by fill and later constructions (Figures 3.14 - 3.16). Two extremely large beams span this space, forming a stepped ceiling, with the north beam lower than the south. The south beam forms the passageway's doorway lintel in the north interior wall of Escalinata, while the north beam forms the entrance beam from the north wall of Building A. The two beams support the fill that lies between these two walls.

The stepped ceiling formed by these two beams suggests that below the debris lies a staircase, a conclusion reached as well by Rowe (ms.b:129, 132). What was the form of this staircase and how did it connect the outside and the double staircase inside Escalinata? To explore this, the first step is to analyze how the three staircases would have intersected in the gallery. Patterns of staircase construction at Chavín suggest that the bases of the double staircases meet at a landing, and that the landing is the width of the passageway to the north. Rowe reaches the same conclusion (ms.b:129). To estimate where this landing sits, the slopes of the stairs are drawn as lines in CAD, continuing down until they meet. They meet in the middle of the double staircase at a point that aligns with the center of the north passageway. This suggests that the landing is centered between the staircases and aligned with the doorway. Given the pattern at Chavín that landings are as wide as the passages they connect, the landing must be as wide as the passageway to the north. The landing therefore must sit at the elevation where the slopes of the stairs intersect the width of the segment going north, as marked by the original walls of the segments going north. The points of the intersection on east and west are symmetrical with respect to the entrance and to the double staircases, and they lie at the same elevation, showing that the landing sits 1.75 m below the bottom of the interior beam and is 2.52 m wide. Apparently during Rowe's visit in 1963, this landing was not fully obscured as it is today: his sketches show a clear landing. The above estimates are consistent with his measurements at that time: he measured 1.74 m between the landing and the bottom of the inside beam, and 2.51 m as the width of the landing (Rowe ms.b:130, 128).

How large was the north entrance doorway, and to what level did the stairs from the internal landing descend? Because all external doors at Chavín are taller than they are wide, we can conclude that this door was taller than 2.52 m. A maximum height of 3.20 m places it at the level of the base of the NEA, which is defined as the intersection of the East Face North Seam and the floor found at its base in Rick's excavation (Rick et al. 1998). Which is the more reasonable estimate? With a base at this level, the stairs leading north would have the same slope

as the stairs in the east and west staircases, with room for a small 0.70 m landing under the entrance beam, a pattern also common at Chavín. Therefore, while the doorway could be between 2.5m and 3.2 m high, it is unlikely that it is closer to 2.50 m, because it would have been square. It more likely sits at or close to 3.20 m, because 3.20 m makes its proportions more similar to other doorways at the site, and it places the doorway at the base of the NEA. In either case, the base of the doorway was very close to the base of the NEA.

An interesting feature of these stairs is that people cannot be seen through the entrance once they reach the central landing; the central landing sits just 12 cm below the bottom of the outer beam. Between this landing and the highest reaches of the staircases at the top of the temple, people on these stairs would not have been visible from the exterior.

Relieving window

Directly above the north entrance stands an open space in the north face of the NEA and the north wall of Escalinata, observed in our analysis and confirmed by Rowe (ms.b:131), who called it a relieving window. The outlines of this relieving window are still visible, although it is partially filled with later constructions (Figures 3.16 above, 3.17). It is bounded on the east by an edge relatively unobscured by later additions, rising directly above the east edge of the doorway (Figures 3.18 - 3.20). On the west a similar edge is abutted by later additions (Figure 3.12 above), but also stands directly aligned over the west edge of the doorway below. These edges rest directly on the interior beam and the tie beams form part of their edges. The original height of the relieving window is unknown, as the top of the north wall above the window has disappeared, but it was at least 3.03 m tall, as the west side currently stands at this height. This height gives rise to the speculation that perhaps the relieving window was the same height, 3.20 m, as the estimated entrance doorway below. A long fallen beam currently lies diagonally across the relieving window; it measures approximately 1.90 m, but appears broken, suggesting that it could have

been long enough to span the 2.60 m-wide space between the uprights, and giving rise to speculation that it originally could have spanned the relieving window.

The function of the relieving window was to reduce weight on the beams below. Without the relieving window, the beams of the north passageway would have had to support the weight of the entire north wall directly over them. Even as massive as these beams are, this would have been an enormous load. The relieving window is centered in the staircase, directly above the north entrance; interestingly, one of two vents that connect with Alacenas through the south wall of the gallery is centered within the relieving window. This vent and the role it may have played are investigated below.

The construction of this area indicates that the relieving window was built at the same time as the support beams and the rest of the south and north walls, and thus with the north entrance doorway.

Ceiling beams

Currently ceiling beams span only the west staircase, even blocking the top of the steps. No beams exist over the east staircase, where the north wall that once supported them has fallen away at the level of the ceiling. The outline of the top of the east end of the south wall mirrors the outline of the top of the west end of the south wall below the west beams, at the same elevation; this suggests that beams did previously cover the east side at this level, in a stepped layout mirroring those on the west. This suggestion is supported by actual measurements reported by Tello (1960) and Rowe (ms.b) on the ceiling when it was fully or largely intact. They indicate that as late as 1963 ceiling beams still spanned the whole gallery, including the east staircase.

As mentioned above, ceilings above staircases are stepped. The ceiling of Escalinata apparently exhibited this pattern as well. Currently the intact ceiling beams and the imprint left by fallen beams step down from the east and west ends of the gallery, and then step up in the area over the relieving window, for a total of 5 ceiling steps each. This concurs with Rowe's (ms.b)

reports and measurements. Tello (1960), however, reports that the ceiling continued to step down towards the center, reaching its lowest point over the center of the gallery. The north wall is missing at this level on the east staircase (see Figure 3.6 above), but the south wall remains intact above this level, suggesting the ceiling in fact stepped up over the center of the gallery. It is worth noting that drastic deterioration apparently has occurred in this gallery since Rowe's visit, including the collapse of the ceiling of the east staircase.

The stonework of the top of the west staircase and its ceiling indicates that the top of the staircase was closed off in a post-Chavín period. The western-most beams lie over late period supports, blocking the top of the stairs (Figure 3.21). The beams themselves are very small, much shorter and narrower than the massive original beams just to the east (Figure 3.22). The north and south walls of the west staircase contain late post-Chavín walls that support these short beams, which are too short to span the space unaided. Their size, the fact that support walls were added to narrow the space so that it could be spanned by these small beams, and the fact that the supports are haphazardly constructed suggests that these small beams have been placed by later populations and that the staircases remained open during Chavín times. The stonework of these additions corresponds with stonework found in the entrance area of the gallery and thought to be post-Chavín. The west staircase, according to Marino Gonzáles and Rowe (ms.b), was used as a corral in recent times.

On the east side, while the beams themselves are gone, crude support walls constructed like those on the west stairs suggest that the east stairs were also blocked after Chavín times (Figures 3.23 - 3.25).

A support column of stones to the north rests on the west tie beam (Figures 3.26, 3.27, 3.6 above). Marino Gonzáles confirms this was built by him to prevent the remaining overhanging beams from collapse (personal communication, 1998; Rick and Gonzáles interviews, 1995-1998).

Landings

The east and west staircases each contain a landing approximately half-way up. These two landings do not currently sit at the same elevation, but they do appear to have been at the same level originally. The steps in the gallery, as is common in most staircases at Chavín, are largely built of single stone blocks. However, just below the current east landing lie two steps built of many patched-together small stones (Figure 3.28 - 3.30). Their construction suggests that they are not original steps. Their placement suggests this as well: the east landing sits two steps higher than the west landing, and is not a flat, cleared landing, but is covered with piled dirt. This landing appears to have been raised by the addition of these two steps; the original landing likely sits below them, or was destroyed. The construction and placement of these two steps suggest that the two landings originally were at the same elevation, and that the two staircases were symmetrical, consistent with the rest of the gallery. This symmetry extends even to the elevation of each visible step: each of the other steps on the east staircase aligns almost exactly with its visible counterpart on the west staircase.

Vents

The south wall of Escalinata contains two vents that connect to Alacenas. One vent opens over the west staircase, the other is centered in the opening of the relieving window.

Maximum Elevation

The maximum elevation of the Escalinata staircases would have been as high or higher than the top of the beams spanning the gallery, leading to the top of the building containing the gallery; exactly how high is unclear. The present highest steps on the east are partially missing (see Figure 3.29 above) due to severe erosion of the top of the building in its northeast corner. Maps II and III in Lumbreras and Amat (1965-1966) suggest that the stairs may have climbed

higher than they do currently, indicating steps at the top of the east stairs turned and climbed south. Rowe (ms.b:131) however, does not record any steps that turn to the south.

Batter

The inner walls of Escalinata are battered, causing the width of the gallery to be narrower at the bottom than at the top. The walls of Escalinata, however, were not exterior walls: these walls have batter because they are tall. This suggests adjusting the definition of the application of batter at Chavín to apply to tall walls, whether internal or external. Batter therefore applies generally to external walls not merely because they are external but because they tend to be tall: as is seen later discussions, short external walls do not exhibit batter. Thus, batter is applied in the construction of tall walls, internal and external, likely as a construction technique to prevent collapse.

Plaster

Plaster currently exists in numerous places throughout the gallery, particularly on the north stairwell wall, the west stairs, and the west buttress beam. (Figures 3.31, 3.32). This suggests the whole gallery was covered with thick plaster. Lumbreras and Amat (1965-1966:152-153) note that the plaster is more than 5cm thick in some areas, with various layers. Rowe (ms.b:131, 135) reports,

“On each side of the relieving window is a great stone beam (viga) tying the walls of the stairwell together. These vigas were plastered with mud plaster, wrapped with rope, and plastered again. MGM [Marino Gonzáles Moreno] says there are two layers of rope wrapping. The whole interior of the stairwell was heavily plastered with mud plaster, including the risers and treads of the stairs. The plaster is best preserved on the west stair which is covered.”

Interestingly, the plaster on the side of the west tie beam covers small coursing layers that rest on the beam (See Figure 3.26 above), suggesting that the beam was heightened before plastering.

Late constructions

The entrance to Escalinata was partially blocked by post-Chavín constructions, built of small stones with little mortar, similar to those in the rest of the gallery. The late stone walls form a narrow passage out the north passageway, creating rubble-filled areas on either side (see Figures 3.14 and 3.15 above). A structure sits above the landing between the two staircases (Figures 3.33, 3.34). Rowe states that the entrance on the north side of the structure “is over half filled in and is partly blocked as well by side walls of small stones representing a later addition eventually used as a tomb” (ms.b:129). He states that Chavez and Gonzáles excavated this tomb while he was in Chavín, concluding that it was at least in part post-Chavín (ms.a:117).

Other later additions exist as well. Seams indicate that wall additions were abutted to the relieving window after its construction (see Figure 3.12 above). The east and west stairs contain late walls supporting their ceilings, as described above.

Summary of gallery form and construction

The coherent original design of Escalinata, as well as the lack of any evidence for Chavín-period construction seams or modifications, indicate that Escalinata was constructed in one highly planned episode. The coursing of its north and south walls is consistent, despite the loosened mortar and missing chinking stones at the top of the south wall, which appears to be a result of deterioration of the top of the exposed wall, rather than a difference in stonework. Symmetrical beams tied together the north and south walls. The double staircases descended to meet at a now-buried landing from which a now-buried set of stairs descended through the north entrance. Above this north staircase and its monumental doorway stood a large relieving window, centered within the gallery, across from a vent in the south wall that leads to Alacenas. The symmetry of the space is remarkable: the levels of the stepped ceiling beams mirror each other across east and west, climbing with the stairs, and likely staying high in the center over the relieving window; the north entrance and relieving window are centered in the staircases, the

staircases and their landings are symmetrical, and even their individual steps mirror each other. The layout, use, and symmetry of the space were changed by post-Chavín constructions that partially obstructed the entrance, filled in the base of the staircase, and closed off the top of the west staircase. The space has also deteriorated significantly with the partial collapse of ceiling beams, the north wall, and the top of the east staircase.

Escalinata is arguably the grandest and most innovative gallery at Chavín. Its entrance was truly monumental. It contains beams more massive and interior walls taller and containing more batter than elsewhere in the galleries. It also contains features unique in the site such as the tie beams, the relieving window, and the double staircase form aligned parallel to the exterior wall and ascending perpendicularly from a single entrance staircase.

The Alacenas Gallery

Alacenas lies in the northeast corner of Building A, south of Escalinata and west of the East Face Gallery (Figures 3.35 - 3.37). Construction evidence suggests it was built in two episodes (Figure 3.38). The first episode was entered via a single staircase that descended likely from the top of the NEA. The second episode is an excellent example of how galleries were modified; part of the gallery's ceiling underwent significant deconstruction so that a second entrance could be built.

Construction and Modification of South Entrance

A modern entrance currently exists at the south entrance to Alacenas, but the stonework suggests it may have undergone modifications in Chavín times. When Marino Gonzáles discovered the gallery after 1945, it could only be entered from the east, as the south entrance was blocked with collapse (Lumbreras and Amat 1965-1966:153). Gonzáles subsequently cleared and consolidated the south entrance, creating an additional access to the gallery. He built a vertical

shaft of walls on the east, south, and west of an original landing above stairs leading down to the gallery (Figure 3.39). The shaft is built of small stones and intermittent foot-hold pegs (Figure 3.40), with which one descends to the top of the landing after descending from the temple surface via a small set of steps to the north. The last of these steps is an original beam that spans the stairs below.

Distinct seams on the east and west walls of this area mark the boundary between large Chavín stones and the small stonework of Gonzáles's consolidation. Original stones extend south past the southmost beam into the shaft, terminating in an irregular edge rather than a distinct straight wall or clear doorway edge (Figures 3.41 - 3.44). Because entrance doorways are flush with the beams above them at Chavín, the irregular termination of original stonework extending beyond the beam suggests that the staircase originally extended farther to the south, continuing to climb. The upper reaches of the stairwell likely either collapsed or were torn out and possibly filled in, perhaps by the addition of a later structure in the area.

Because the south entrance possibly was modified in Chavín times and a new south entrance was constructed in modern times, it is difficult to fully decipher this area's full construction history. It does seem clear, however, that, due to modifications to the top of the south entrance, the gallery eventually required an east entrance. While it is possible that a new entrance was built even as the south entrance remained open, this seems unlikely, given the difficulty in modifying the east segment of the gallery and the awkwardness of the resulting east entrance, as discussed below. A more plausible explanation is that access to the south entrance was inhibited or blocked by later constructions, requiring a new entrance—a hypothesis examined in the next chapter.

Construction and Modification of East Entrance

To accommodate this new entrance, the east segment of the gallery, Segment A was deconstructed, modified, and reconstructed. The architecture indicates that a corbel and the beam

above it were lifted out, and a layer of beams stepping up to the east was laid down across the gap (Figures 3.45 - 3.47), creating a seam. This seam is referred to here as Ala-A-1, following the naming conventions described above. The modification process may have involved removing the other beams and corbels as well, and laying them or new ones down in a configuration better able to withstand the added weight from above. These modifications created an opening through the ceiling over the east wall. A small segment to the east was built adjacent to this opening, connecting to a set of steps turning north and leading up out the gallery. The top of this entrance has been slightly consolidated by Marino Gonzáles.

Presently, passage through this entrance is difficult because it opens into the gallery at the level of the corbels. How the east entrance functioned is unclear. Perhaps a set of steps were built against the wall to facilitate access – and were later removed.

Construction and Features of the Rest of the gallery

The remainder of the gallery appears to have been built with the South Entrance in the first construction episodes, as it contains no clear seams. Three corners of the gallery exhibit some abutment, but these appear to be merely remnants of the gallery's construction technique, not markers of major construction events. The half-doorway between A and B has seams on both sides; its stonework and placement strongly suggest it is a post-Chavín addition (Figure 3.48).

Alacenas contains a number of different architectural features that enter into later analyses. Alacenas contains numerous niches, after which the gallery was named; Lumbreras and Amat (1965-1966:153) propose that their small size suggests they may have been more similar to tenon head sockets than to functional niches. The gallery also contains two vents that connect with Escalinata to the north, one over Escalinata's west staircase and one directly centered over Escalinata's north entrance and visible through its relieving window.

Overview of gallery form and construction

The evidence presented above suggests that Alacenas was built in two episodes. In the first episode, the present general form of the gallery was constructed, with two large side segments connected by a smaller central segment. The staircase climbing south from this central segment formed the gallery's original entrance, and it likely climbed farther and higher to the south than it does today. In the second episode, a new entrance from the east was created by removing a beam in the east segment of the gallery, raising the ceiling at that location, and building a covered landing and small staircase up and out of the east side of the gallery. Major modifications to the east segment altered the gallery's original form and access.

The addition of a new structure that blocked the south entrance best explains the construction of the second entrance. While construction of the second entrance did not necessarily have to rely on an obstructed south entrance, the irregular termination of original stonework at the top of the south entrance landing, the effort required to lift the beam in the east segment and build the new entrance (which would have required first removing all fill above the gallery), and awkward, atypical yet clearly Chavín-period architecture of the resulting east entrance all support the conclusion that the east entrance was built out of necessity. This hypothesis that a later structure blocked the south entrance will be examined in following chapters.

The East Face Gallery

The East Face Gallery is located near the northeast corner of the NEA. It was recognized and partially documented by Rowe (ms.b:83). As it was not named by him, and does not appear in publications regarding the galleries, it is referred to here as "The East Face Gallery" due to its distinct opening into the east face of Building A (Figure 3.49, 3.50). The interior is partially filled with massive fallen beams and rubble resulting from the collapse of its upper portions. It

appears to have been built in one episode (Figure 3.51 - 3.54). It was a staircase, likely was entered from the top of the building and not the bottom, functioning as a "hanging staircase".

Form and Construction of the Gallery

The two steps evident in the dirt fill over the floor near the entrance, the stepped ceiling, the slope of the rubble inside the gallery, and the significant elevation gain as one continues into the gallery all indicate that this gallery was a staircase. Rowe (ms.b:83) noted three steps rising from the entrance.

Close examination of the interior of the gallery revealed no seams, suggesting it was built in one episode. The interior stonework of the gallery is large, with a well-made ceiling well-integrated with the walls (Figure 3.55), suggesting no deconstruction occurred. Eventual clearing of the collapse that obscures portions of the walls may reveal hidden seams, but analysis of the visible walls and the gallery's form make the presence of construction seams appear unlikely.

Collapse of the gallery's upper portion

Large intact beams comprise half of the ceiling of the gallery's upper-most area (Figure 3.56). The other half is blocked by fallen beams, stone blocks, and other rubble (Figure 3.57). The walls and ceiling up to this point are intact, yet the gallery is largely filled with rubble that has fallen through this space (Figure 3.58), almost reaching the gallery's opening on the east face. The presence of these fallen beams and collapsed stones suggest they fell from higher walls or ceiling levels, from which we can conclude that the gallery climbed higher than its present maximum elevation. How high the gallery might have climbed is difficult to estimate based on the number of fallen beams, but the large amount of collapse suggests a significant portion of the gallery existed above the present maximum elevation of the gallery. The amount and positions of the rubble, including the large beams, suggest that the gallery was blocked by collapse, rather than purposefully closed off.

In the segment closest to the East Face of Building A, stones also appear to have fallen in from the ceiling and walls between the first two beams. The resulting rubble partially fills the segment (Figure 3.59). Similar gaps between ceiling beams are found in the Marino Gonzáles Staircase, described below.

East Face opening and support pilaster

The opening of the gallery on the East Face of Building A is very low, measuring only 1.38 m high; it seems unlikely that it was made for people to enter or stand in at full height (Figure 3.60). The first step is situated approximately 0.63 m from the façade.

On the north side of the opening a pilaster of small stones supports the beam above the opening (See Figures 3.60 above, 3.61). The construction of this pilaster suggests it was a late addition, but its placement suggests it was built at the time the beam was placed, as the beam appears to be too short to span the entrance without this pilaster. The construction history of this area is unclear. It may be related to the patched-looking area north of the gallery opening, and may signify possible deconstruction and modification of this area.

East Face Vent

The East Face vent is located directly north of the East Face Gallery (See Figure 3.50 above). Their proximity implies they are in some way associated with each other. The vent is large, built of large beams and wall stones, which is abnormal for vents. It extends west straight into Building A approximately four meters, then terminates in gravel and dirt. The cross-section of the vent does not taper as it exits the building. The fact that it is level implies it was not a drain, but rather a vent that likely connected with a gallery or other interior space at the same level; such an internal space has not yet been identified. Such large vent openings on the exterior are uncommon; in fact, this is the largest of the known vent openings.

Summary

The East Face Gallery was a staircase that extended higher than present, likely to an entrance at the top of the NEA. The present upper portion of the gallery descends north to a landing, where it turns east and descends to the east face of Building A. Analysis of the gallery stonework suggests that it was built in one episode, with large ceiling beams and a well-constructed interior of rough stonework.

The Zanja Gallery

The present entrance to the Zanja Gallery is located in the large historic-period trench in the east face of the north portion of Building A (Figures 3.62 - 3.64). This trench cut through the gallery, creating the current entrance into the south end of a single gallery segment (Figure 3.65). Only a small portion of a passageway of the Zanja Gallery is currently accessible. More of the gallery could remain in the southern face of the cut. As this gallery was not noted in other publications, it is referred to here as La Galería de la Zanja, or the Gallery of the Trench.

No seams exist in the visible segment (Figure 3.66), indicating it was built in one episode (Figure 3.67). The construction of the north end of the segment indicates that the gallery continued farther than its current extent: while ceiling beams in the visible segment run east-west, ceiling beams in the north end of the passageway run north-south, supported by a lowered beam just south of the collapsed area. This suggests that the visible passageway intersected with a gallery segment to the north that continued east-west and possibly further north.

Zanja is a reminder that more buried or collapsed galleries may exist in areas that are now inaccessible; without the large historic-period trench, it seems unlikely that this gallery segment would have been exposed.

The Laberintos Gallery and The Pasos Perdidos Gallery

The Laberintos Gallery is located in the northwest corner of Building A (Figures 3.68 - 3.71). It contains three distinct construction episodes (Figure 3.72). It is contiguous with the Pasos Perdidos Gallery and thus they are considered together here. The Laberintos Gallery provides an excellent example of how galleries were modified. Many common gallery construction patterns also are seen here, including stepped ceilings over stairs and stepped canals, and stairs that connect different construction episodes. It also contains some unusual features, such as a curved vent, pegs, and doorway pegs (Figures 3.73 - 3.77).

The Seam Between Upper Laberintos and Lower Laberintos: Lab-E-1

The first seam exists in Segment E of Laberintos (Figure 3.78). It consists of a plane running east-west through the gallery segment, evidenced by abutments on the east and west walls. Following the naming conventions described above, the east side of the seam is called Lab-E-1-e, and the west side of the seam is called Lab-E-1-w. The stonework surrounding the seam indicates that the wall south of the seam was built first. The south stones run behind those to north. North of the seam the hall widens and contains corbels, while in the narrower south segment and its stairs, corbels are absent. Additionally, the large stonework of the south side terminates at the seam in a straight vertical edge, while the smaller, rougher stonework on the north side appears to have been built to fill a space against an existing wall: the north wall courses are less formal, with small stones filling the spaces against straight-edged south courses (Figures 3.79 - 3.84). No evidence of deconstruction is apparent. Stonework differences evident at the seam continue through the rest of the gallery, with the stonework in south of the seam being larger and more finely constructed, and the stonework north of the seam being smaller, rougher, and less formally constructed (Figures 3.85 - 3.91). The stonework at the seam indicates that the walls south of the seam were built first, followed by the episode abutted to the north. The area

north of the Lab-E-1 seam, consisting of Segments A, B, C, D, and the portion of Segment E north of Lab-E-1, is called “Lower Laberintos.” The area south of Lab-E-1, including the stairs in Segment E and the upper level of the gallery, except for Segment O, is Upper Laberintos. Seam Lab-E-1 indicates that Upper Laberintos was built before Lower Laberintos.

The upper portion of the walls immediately north of the seam show atypical construction that suggests that the north side of the seam was modified after its initial construction. On both the east and west walls, the first corbels just north of the seam are separated from the ceiling beam above it by a course, rather than sitting directly beneath the ceiling beams like they normally do (Figures 3.92 - 3.95). This implies that the ceiling beam originally sat on the corbel, was lifted, and a stone set on top of the corbel to raise the beam. This modification would make sense if it had been done to accommodate the addition of the south segment to the north segment by creating a stepped ceiling over the step to the south segment. However, this possibility does not override the more conclusive abutment evidence that indicates the north wall was built after the south wall. Rather, it appears that this atypical corbel construction indicates either a miscalculation in the original construction of the walls north of the seam, or, more likely, that the level of the ceiling beam was adjusted after the original construction of the added north segment to accommodate that step in the floor at the plane of abutment.

A ceiling beam partially spans the seam (Figure 3.96). The beam crosses from north to south on the east side, sitting primarily north of the seam, in the later episode. This configuration is similar to one in Lanzón, as seen below, in which a beam primarily in a later segment crosses the seam over to the earlier episode. This appears to be a result of the construction of these types of seams, suggesting that this ceiling beam was placed at the time of abutment, perhaps replacing an original beam at the edge of the older segment, in order to integrate with the addition.

The end walls in Segments C and D align along the same plane as Lab-E-1, and therefore seams would be expected at these end walls as well, indicating Segments C and D were abutted against earlier walls aligned with Lab-E-1. The stonework in Segments C and D, is not

completely clear (Figures 3.89, 3.97, 3.98). Segment C appears to contain no seams. The end wall corners of the south wall are somewhat obscured by mud, but the stones of the side walls do not appear to abut the end wall. Additionally, the courses of the end wall generally align with those of the side walls, the east corbel rests on the end wall, and the ceiling beam rests on the end wall. Most importantly, the stonework of the end wall is the same as that of the side walls, and matches the rest of Lower Laberintos; it is small, rough, with much chinking and mud. In Segment D, however, the end wall stonework differs from the stonework in Segment C: the stones in the top three courses are much larger than those in Segment C and in most of the rest of Segment D. They are closer in size to the stones south of the seam in Segment E. The lower courses are smaller. Additionally, the side walls appear to abut the end wall, but the stonework is not completely clear largely due to mud covering the corners, and the stone at the bottom of the vent in the east wall appears to interlink with the end wall. The southmost corbels do not sit atop the end wall, but rather abut it. The ceiling beam sits atop the end wall. Overall, the coursework in Lower Laberintos allows the tentative conclusion that an end wall seam exists in the south end of Segment D but not in Segment C. The stonework in the southwall of Segment D suggests that it could have been built at the same time as Upper Laberintos, and that it in fact connected with the west wall of the entrance to Upper Laberintos, possibly forming an outer north wall west of the entrance. The stonework in Segment C, however, suggests that the end wall did not connect with Segment E, but rather was built at once with the rest of the segment. An interesting note is that the two sides of the seam in Segment E do not exactly align, with the east side of the seam sitting approximately 12cm north of the west side. The end wall of Segment D aligns with the west side of the seam, while the end wall of Segment C sits farther north and aligns with the east side of the seam.

Taken together, these data on Lab-E-1 and Lower Laberintos imply the following construction scenario: an entrance to Upper Laberintos opened directly to the north at the current location of Lab-E-1, with a wall extending west at least past Segment D's west wall, and an east

wall extending no farther east than the west wall of Segment C. When Lower Laberintos was constructed, Lab-E-1 was created at the former entrance to Upper Laberintos, Segment D was built up against the former north wall west of the entrance, aligning with the west edge of the doorway, and Segment E was built east of the north wall east of the doorway. The lack of vents west out of Segment D suggests the area to the west of Lower Laberintos was not open, while the vents leading to the exterior from Segment C indicate the area east of Lower Laberintos was open.

Seams between Upper Laberintos and the Laberintos Alcove: Lab-O-1 and Lab-E-2

The second seam in the Laberintos Gallery is located in Segment O or the “alcove”, the small segment located north of the stairwell of Upper Laberintos (Figures 3.99, 3.100). Here the seam is identified as Lab-O-1.

The stonework of Lab-O-1 clearly indicates that an exterior wall was broken through and a new segment abutted to the north. The vertical strip of wall immediately south of the seam consists of single courses of thick stones recessed perpendicularly into the plane of the wall, alternating with two courses of thin stones protruding perpendicularly out past the plane of the wall into the space of the gallery (Figures 3.101 - 3.109). Together these stones form an ABB pattern. The east and west walls mirror each other, with recessed single thick courses across from recessed single thick courses, and protruding double thin courses across from protruding double thin courses. Mortar is present on the outward surfaces of some courses. The construction of this alternating coursing of recessed and protruding stones in an ABB pattern, and the alignment of this wall with the exterior north face of Building A, as shown in Level 3 analysis, indicates that these stones are remnants of an external wall that used to exist here, running east-west, and that stones were ripped out to form an opening through the wall with edges that conformed as closely as possible to the smooth faces of the walls. The seam sits to the north of this former external wall. The stonework of the wall north of the seam indicates it was abutted up against the south

side and therefore that the south side of the seam was built first. No seam exists in Segment E below this seam. These data indicate that Upper Laberintos was built before the addition north of Lab-O-1, and that an external wall was broken through to enable the addition north of Lab-O-1.

Stonework evidence immediately south of Lab-O-1 suggests that the part of the alcove south of Lab-O-1 did not exist before the external wall was broken through. Rather, it suggests that the stairs in Segment E originally were covered by a stepped ceiling that later was extensively deconstructed and modified, essentially removed and replaced with walls to form a connection with the exterior. Small, irregular stonework lies between the former external wall and the large, regular stonework to south of the step into the alcove (Figures 3.110, 3.111). The border between the small irregular stonework and the large regular stonework steps down to the north on both east and west walls, terminating near the first alcove step. This stepped border lies directly over the stairs descending to the lower hallway.

This evidence suggests that originally the stairs in Segment E were completely covered by a stepped ceiling, following the site-wide pattern in which stepped ceilings cover internal staircases. The beams of this stepped ceiling rested on the large wall stones that now form the border with the small irregular stones, stepping down near to what is now the first alcove step, and descending to the lower hallway as the original stones still do today (Figures 3.112 - 3.114). Fill existed between the stepped ceiling and the exterior wall to the north. A significant deconstruction event then took place which involved removing the highest beams in the stepped ceiling and the fill between them and exterior wall, and breaking through the exterior wall. The space was then rebuilt, using small stonework to fit in the irregular space to connect the original gallery walls to the exterior wall. An addition was built north of the seam, creating an entrance at the level of the upper gallery. In sum, an original stepped ceiling was deconstructed and rebuilt as a hallway to lead through former fill to an outside exit. A seam exists where the stepped ceiling stones were removed and the small stonework was added; this is called Lab-E-2. The Laberintos Alcove was therefore a separate episode, built after Upper Laberintos, that required two seams:

Lab-E-2, where the beams were removed, and Lab-O-1, where the external wall was broken-through, each connected by walls of irregular small stonework in the alcove portion between them.

The full length and form of the alcove past the external wall is not known. Marino Gonzáles reported that he closed an exterior opening in the northeast corner of the alcove to prevent tourists from entering the gallery here (Figures 3.115 - 3.117). Seam evidence here suggests, however, that this opening was not the original entrance. The ceiling above the north end of the alcove and a seam in the west wall of alcove, marked by a jagged edge and a coursing change (Figure 3.118), suggest that the north end of the alcove was reconstructed before the door in the west wall was filled. It appears that the Alcove could have extended farther north as well as east than at present.

Two shallow niches or sunken panels sit in the walls of the stairwell between the Alcove and Upper Laberintos (Figures 3.119 - 3.121). The form of these niches suggests they originally may have been used to hold something like planks to close access between Lower and Upper Laberintos (Roosevelt 1935:40; Lumbreras and Amat 1965-1966:151-152). Analysis of the stonework here indicates these niches were built during the Upper Laberintos episode rather than the Alcove episode, in that they are constructed of the large stonework of Upper Laberintos and lie south of the Lab-E-2 seam. It follows therefore that these niches originally could have been used to close off access between the lower and upper galleries, but that they were not built as a way to cross to the Alcove, because the Alcove was not yet constructed. Following the construction of the Alcove, the niches would have provided a way to connect Upper Laberintos directly to the exterior.

Relative chronology of the Upper Laberintos, Lower Laberintos, and the Alcove

Upper Laberintos clearly was built before both Lower Laberintos and the Laberintos Alcove, with its original entrance located at the seam in Segment E. The relationship between

Lower Laberintos and the Alcove is not as straightforward. The Alcove as it currently stands does not vertically overlap Lower Laberintos. However, if the Alcove extended farther to the north and east as its stonework indicates, it would have crossed over Lower Laberintos, suggesting Lower Laberintos was built either before or at the same time as the Alcove. Access to the Alcove from the exterior likely relied on Lower Laberintos being in place; otherwise, the entrance to the Alcove would have stood a level above the entrance to Upper Laberintos, with uncertain means of access; this suggests the Alcove was not built before Lower Laberintos. For these reasons, I hypothesize that Lower Laberintos was constructed before or at the same time as the Alcove.

Pasos Perdidos

Pasos Perdidos consists of set of vertical shafts and stepped, slab-lined canals covered by stepped ceilings. It was documented, along with the Laberintos Gallery, by Roosevelt (1935:Figure 23) in his visit to the site in 1934 accompanying Tello. It was given its current name by Lumbreras et al. (1976), who hypothesize that it was part of an acoustic-hydraulic system within the galleries. It forms one of the vertical shaft canal systems within the larger drainage system.

Construction analysis

Pasos Perdidos is currently entered via a hole in the floor of Segment H of Upper Laberintos (Figure 3.122). It is very carefully constructed, with vertical drains, doorway lintels, curving segments, and nicely laid stonework. South of Segment H of Upper Laberintos, Pasos Perdidos ascends and splits into three perpendicular branches containing vertical shafts. To the north of Segment H of Upper Laberintos, Pasos Perdidos descends, curves, and also splits into multiple branches.

In section of Pasos Perdidos south of Upper Laberintos, three independent branches converge into one. In Segment B, the branch to the south, a large vertical shaft opens onto a canal

of extremely steep set of stepped, overlapping slabs that are covered by a stepped ceiling (Figure 3.123). The vertical shaft measures approximately 60 cm x 45 cm and its top is filled with debris approximately 1.32m. It is built of stones approximately 30cm long and 10-15cm high. The canal continues descending, becoming less steep, (Figure 3.124) until it intersects two branches extending from the east and the west. These branches have similar slopes, less steep than Segment B. At its west extent Segment C contains a rubble-filled vertical shaft that drops onto a floor of stepped, overlapping slabs that descend to the intersection, covered with a stepped ceiling (Figure 3.125). It crosses perpendicularly through the vent from Upper Laberintos, described above (Figure 3.126), which itself continues north through three walls and a doorway of Upper Laberintos to the exterior. The branch to the east is extremely noteworthy. From its highest point, it descends, as the other branches do, via stepped slabs under a stepped ceiling, to the intersection (Figure 3.127). However, rather than stopping at the top in a vertical shaft like the other segments, the canal curves and descends to the northeast (Figure 3.128). Above the highest point of the canal, an upper channel descends through the ceiling, creating a unique double-layered canal (Figure 3.129). The three segments meet in an offset intersection (Figure 3.130) constructed with doorway lintels, and descend north.

Immediately north of the current entrance from Segment H of Upper Laberintos the canal descends steeply, with a floor of overlapping stone slabs and a stepped ceiling. It then tapers in width and height, gets steeper, and then levels out into an area with flat ceiling beams and coursed stonework, some of it built of large rectangular stones. North of the area where the canal levels out, the extremely confined lower portion of the canal contains numerous differences in stonework and possible seams. The stonework and structure of the canal change here; the main passageway contains much smaller and less regular stonework, connects with a system of descending vertical shafts from the northwest, curves to the north with different stonework again, and meets with a descending vertical shaft system containing different stonework. Drawings by

Roosevelt (1935:Figure 23) and Tello (1960:Figure 9) suggest that the system of vertical shafts from the northwest connects with vents extending east from Segment C in Lower Laberintos.

Mapping was difficult (Figures 3.131 - 3.133) due to the confined space of the canal. My team was able to map the intersection and a large part of each branch north of Segment H of Upper Laberintos, but was not able to map the upper portions of each branch or the lower canal north of Segment H.

Sequence of canal segments

The form and stonework of Pasos Perdidos suggests that it was constructed in two primary episodes. The first episode, called Upper Pasos Perdidos, consists of the three branches and vertical shafts south of Segment H of Upper Laberintos, as well as the portion of the canal that descends under Segment H, north to the point where it levels out. These areas contain consistent, formal stonework and construction, as well as no apparent seams, suggesting it was built in one episode. The second episode of the canal consists of the area to the north and east of Upper Pasos Perdidos, where the canal levels out. This is called the Lower Pasos Perdidos. It contains numerous seams, differences in stonework, and changes in form, that suggest that it was added after the construction of Upper Pasos Perdidos.

Relationship with Laberintos Gallery

Upper Laberintos connects directly with Upper Pasos Perdidos through the south-trending vent in Segment H. This vent contains no seams and extends 2.10 m to the north, where it intersects Segment C of Upper Pasos Perdidos. Together with the close proximity of Upper Pasos Perdidos to Upper Laberintos and the functional relationship suggested by their interconnectedness, particularly as proposed by Lumbreras et al. (1976), this vent suggests that they were built in the same construction episode.

The set of relationships between Laberintos and Pasos Perdidos suggests that Lower Pasos Perdidos may have been built with Lower Laberintos. Upper Pasos Perdidos likely was constructed with Upper Laberintos, Upper Laberintos likely was constructed before Lower Laberintos, and Upper Pasos Perdidos was likely constructed before Lower Pasos Perdidos. Drawings by Roosevelt (1935:Figure 23) and Tello (1960:Figure 9) suggest that Lower Pasos Perdidos connects with Lower Laberintos. This suggests that they could have been built at the same time, and that Lower Pasos Perdidos may have been built to continue Pasos Perdidos through the new construction containing Lower Laberintos.

Summary of Laberintos Gallery and Pasos Perdidos

Laberintos Gallery and the Pasos Perdidos Gallery together form a single gallery complex that can be divided into 4 distinct units: Upper Laberintos and Upper Pasos Perdidos, Lower Laberintos, Lower Pasos Perdidos, and the Alcove. Evidence suggests that Upper Laberintos and Upper Pasos Perdidos were built together and before the other episodes. Lower Laberintos and Lower Pasos Perdidos may have been built together as a functional unit. The Alcove was built either at the same time or after Lower Laberintos. The Laberintos Gallery therefore contains three construction episodes: Upper Laberintos with Upper Pasos Perdidos, Lower Laberintos possibly with Lower Pasos Perdidos, and the Laberintos Alcove. Lower Laberintos and the Laberintos Alcove could have been built as part of the same phase. This question is analyzed further in later chapters.

The Laberintos Gallery illustrates many of the building patterns seen in the galleries: the ceilings over stairs are stepped, such as in Segment E and the entrance steps; the stairs in Segment E, which begin at Lab-E-1, connect different episodes; the first episode, Upper Laberintos, was significantly modified to accommodate a later addition, the Alcove, changing the gallery's form and the way it was used; the staircase in Segment E contains no corbels, but corbels are present in parts of Lower and Upper Laberintos; the stonework varies between episodes; the end wall of

Segment D in Lower Laberintos could have been an earlier exterior wall near the Upper Laberintos entrance; Lower Laberintos is entered through descending steps, but the Upper Laberintos episode was not, an interesting situation discussed further below.

The Lanzón Gallery

Overview

The Lanzón Gallery is located in the center of Building B (Figures 3.134 - 3.138). Three seams with significantly different stonework between them exist in Segment E, its central east-west hallway. End wall seams exist in each segment of the Inner Lanzón Chamber. Near the gallery's entrance a possible seam exists. Together these seams document how the gallery was modified over time, indicating it was built in three or four primary episodes (Figures 3.139, 3.140).

Seams in Segment E

In Segment E of the Lanzón Gallery, three seams exist, called here, from west to east, Lan-E-1, Lan-E-2, and Lan-E-3. All of them run north-south through the segment. Examination of abutments at these seams and stonework differences between them suggests that the seams separate three episodes, built from west to east.

The East Seam in Segment E: Lan-E-3

In the east seam, Lan-E-3, abutment evidence indicates that the construction to the west was built in an episode before the construction to the east. A relatively straight west edge on both the south and north walls is abutted by the construction to the east, which contains smaller stones in the mortar by the seam (Figures 3.141 - 3.147). Additionally, the abutment from the east also crosses the seam at the top with a ceiling beam slightly overlapping from east to west (Figure

3.148), as in the Laberintos seam Lab-E-1, in which the beam also spanned from the newer segment to the older. West of the seam sits a gap in the ceiling on both north and south sides, over the top wall course by the seam. The south side (see Figure 3.145 above) has no crossing beam, but it does have a small stone between the beams filling the gap, as if a narrow beam was removed here, or perhaps a very large beam was removed and replaced by the existing smaller one, especially if it was a distinctive doorway lintel. The abutment evidence indicates that the west side of this seam was built before the east.

Consistent with this conclusion is the significant difference in stonework east and west of the seam. East of the seam the gallery walls are built of medium-sized, roughly rectangular stones, with irregular chinking and coursing. This stonework continues throughout the remainder of the gallery to the east, into segments D, C, B, and A (Figure 3.149). In contrast, to the west of the seam, the stonework consists of large, smoother rectangular stones with very clear coursing and chinking. This distinctive stonework exists in this gallery only between the Lan-E-3 and the Lan-E-2 seams, a length of only 2.26 m.

The south side of the seam, Lan-E-3-s, contains plaster, a rare feature visible only here and in a seam in the Columnas-Vigas Gallery, discussed below. Mud from the 1945 aluvi3n that formerly covered the seam has been removed here, revealing the seam. No plaster is visible on the north side of the seam, Lan-E-3-n, but plaster likely exists in this as well as other seams, yet has not been revealed through clearing of the mud from between the stones.

The Center Seam in Segment E: Lan-E-2

The construction data for this seam indicate that walls to the west of the seam were built before those to the east (Figures 3.150 - 3.160). The walls west of the seam protrude 0.015 m further out into the corridor on both north and south sides, narrowing the width of the hallway. These walls terminate in a relatively straight edge at the seam, while the walls to the east fill the space against the seam with patchy areas of small stones, vertical rocks, and mortar that are set

back along with the rest of the walls east of the seam, particularly on the south wall. The seam runs between the ceiling beams, which are similar and well-placed with respect to each other. These data indicate that the episode to the east of the seam was abutted to episode to the west of the seam.

The stonework differences here also are consistent with this conclusion. The large, well-coursed stonework of the walls to the east, described above, differs greatly from that in the walls to the west. The stonework to the west is not clearly coursed, with thin, slablike stones combined with smaller, irregularly shaped stones.

The West Seam in Segment E: Lan-E-1

The construction of this seam is less clear than the previous two because the hallway here is very narrow due to buckling walls, and because the walls still contain remnants of aluvi3n fill between their stones, making observations less clear. A straighter edge east of the seam, particularly on the south wall, as well as less mortar with fewer small stones incorporated in it on the edges east of the seam, and signs of abutment of from the west against this edge suggest that the construction east of the seam likely was built before the construction west of the seam (Figures 3.161 - 3.164).

Stonework differences are not as clear here, perhaps in part due to the poor condition of the walls.

Possible seam near entrance: Lan-B-1

The south wall of Segment B in the Lanz3n Gallery appears to be a filled-in doorway (Figures 3.165, 3.166). The stonework and mortar of this wall are clearly different than those of the adjacent walls. Within the south wall itself, the bottom courses are flat and more regular than the courses above them. The courses on the south wall do not align with those on the adjacent walls, particularly to the east. The west wall runs behind the south wall. Additionally, a large

beam above the fill spans the wall, its ends supported by the east and west walls. This could be a former doorway lintel, as it follows the construction pattern of the doorway lintels to Segments C, D, and E (Figures 3.167 - 3.169), not the construction pattern of end walls, which have no large stone spanning the top of the wall. The recessed section adjacent to and above the beam to the west is unusual; the partly stepped structure of the ceiling and beams almost suggest a staircase of some sort existed here, up or down (Figures 3.170, 3.171). It is not clear when the south wall might have been filled, but González says he did not fill it (González, personal communication, 1998), and the wall is present in Tello's map (1960:Figure 9) indicating that the wall likely was filled earlier than this. Where a passageway through this doorway may have led is unclear, but the possibility that the passage extended south, and possibly up or down, is intriguing.

Inner Lanzón Chamber

At the west end of Segment E lies the cruciform Inner Lanzón chamber. The Lanzón monolith stands in a small central square from which short side segments extend to the north, west, south, and east. The east segment of the cruciform joins with the west end of Segment E.

Seams, Stonework, and Construction History

The north, west, and south segments of the Inner Lanzón chamber contain end wall seams, in which the side walls of the segment abut the end wall. The stonework of the three endwalls is similar, with regular courses and chinking, while the stonework of the side walls of each segment is similar, but differs from the end walls and is built with smaller stones in less regular coursing.

In the south segment of the Inner Lanzón Chamber, Segment F, the stonework indicates the end wall was abutted by the sidewalls, creating seam Lan-F-1 (Figures 3.172 - 3.176). For example, the corners of the top two and lower two courses are somewhat obscured by aluvi3n, but most of the visible end wall stones run behind the side walls with no interlocking. The end wall is

clearly coursed, comprised of medium and large stones relatively consistent in size from top to bottom, with significant regular chinking in the lower half of the wall and very little in the upper half. The side walls have irregular coursing, with small, medium, and large stones, and irregular chinking. The coursing of the end wall and sidewalls do not align. These features indicate that the side walls were built up against the end wall (Figure 3.177).

Similarly, in the west segment, Segment G, the sidewalls clearly abut the end wall, creating seam Lan-G-1 (Figures 3.178 - 3.182). The end wall is built with consistent stonework in relaxed courses that are less clearly defined and that contain less chinking than in the north and south segments. It is constructed of medium-large stones, with larger stones in the higher courses and smaller stones around the vent at the base of the wall.

In the north segment, Segment H, aluvi3n obscures the corners of the top three courses, but an end wall seam (Lan-H-1) is clear below this level, in which the side walls abut the end wall (Figures 3.183 - 3.189). The top two courses are comprised of single medium-large stones separated by chinking, while below this the wall is comprised of medium-large stones with chinking. The coursing and chinking are regular. The side walls have relaxed coursing and some chinking. The differences in stonework of the top courses of the end walls of Segment H and Segment F suggest horizontal seams may exist there, but the evidence is not conclusive.

Segment I, east of the Lanz3n monolith, connects with Segment E at the seam, Lan-E-1, described above. Its side walls have relaxed coursing with little chinking, containing gaps from which it appears chinking has fallen, and stonework size and construction resembling that of the sidewalls in the other segments (Figures 3.190, 3.191). Its walls currently are bowing. The southwest corner of Segment I, as well as other areas in the Inner Lanz3n chamber, have been consolidated by Marino Gonz3les (personal communication, 1998; Rick and Gonz3les video interviews 1995-1998). These areas can typically be identified by smaller, irregular stonework (Figures 3.192 - 3.194).

The side walls of adjacent side segments meet towards the center of the chamber, forming corners that define the central square space around the Lanzón monolith. At each corner, the stones interlock. These interlocking corners and the similar stonework of the side walls of adjacent side segments suggest that the side walls of adjacent segments were formed by large "support blocks," each built as a unit (Figure 3.195).

Taken together, the seams and stonework in the Inner Lanzón chamber suggest that the end walls of the chamber were part of a continuous rectangular wall, here called the Inner Lanzón Rectangle, that formed the outside of the chamber. Additionally, they suggest that the support blocks were built up against the corners of the square, creating the cruciform space that could then be spanned by stone ceiling beams. The ceiling beams spanning the side segments rest on both the side walls and the end walls, indicating that the ceiling beams were placed after both the Inner Lanzón Rectangle and the support blocks were in place.

This conclusion suggests that the wall segment between Lan-E-1 and Lan-E-2 in Segment E forms the original opening of the Inner Lanzón Rectangle. Lan-E-1 is the seam between the support blocks of Segment I and the Inner Lanzón Rectangle, while Lan-E-2 marks the outer plane of the Inner Lanzón Rectangle. East of Lan-E-2 lies the finer stonework of the Middle Lanzón episode, which was abutted to the east face of the Inner Lanzón Rectangle, as shown at Lan-E-2.

It is possible that the support blocks and ceiling were built in the same episode as the Inner Lanzón Rectangle, as part of a construction technique that created endwall seams between the Inner Lanzón Rectangle and the support blocks. However, the differences in stonework between the Inner Lanzón Rectangle and the support blocks suggest that they were built in two different episodes, named the Inner Lanzón Rectangle episode and the Inner Lanzón Chamber episode. In the Inner Lanzón Chamber episode the cruciform likely was roofed, following the construction of the support blocks. This suggests that the Inner Lanzón Rectangle was an open

and likely free-standing structure. If it was roofed, it likely was roofed with a material other than stone, given that it measures 6.65m x 6.79m.

Vents

Vents in the Inner Lanzón Chamber indicate that the Inner Lanzón Rectangle originally contained vents opening to the east and the west. A vent in Segment G connects to the west face of Building B. In Segments F and H, two vents trend east through the east support blocks. Three-dimensional measurements into the two vents in Segments F and H indicate that they continue through the Inner Lanzón Rectangle encompassing the chamber. This suggests that when the support blocks were built, vents were built in the blocks to connect vents in the Inner Lanzón Rectangle to the Inner Lanzón Chamber. When these vents pass the outer extent of the wall, they curve inward toward Segment E. This suggests that the vents were continued through later additions to the east.

The very presence of vents in the Inner Lanzón Rectangle suggests that the Inner Lanzón Rectangle may originally have been roofed, perhaps with wood, as the presence of vents implies that the space was “interior.” It is possible, however, that the vents could have been built in the walls without the space being roofed.

The Lanzón Monolith

The Lanzón monolith (Figures 3.196 - 3.198) likely was in place by the end of the construction of the Inner Lanzón Chamber episode. The form of the Inner Lanzón Chamber appears to have been designed to enclose the Lanzón monolith. Whether it was in place within the Inner Lanzón Rectangle prior to the construction of the Inner Lanzón Rectangle is not clear.

Pegs

In each side segment, at similar elevations, small, narrow stone pegs protrude perpendicularly out of the walls (Figures 3.177, 3.189, and 3.195 above; Figures 3.199 - 3.204). In Segment H they are in their original positions, but in Segments F and G some pegs were reinserted into their original positions in the walls by Marino Gonzáles (Gonzáles, personal communication, 1998; Rick and Gonzáles video interviews 1995-1998). A possible significance of these pegs is addressed in later chapters.

Summary and Implications

The Lanzón Gallery appears to have been built in three or four primary episodes. In the first episode, the Inner Lanzón Rectangle episode, a rectangular wall opening to the east was constructed, likely as a free-standing structure. In the next episode, the Inner Lanzón Chamber episode, the corners of this rectangle were filled in with support blocks, and the resulting narrow side segments were roofed with stone ceiling beams. The Middle Lanzón episode was constructed, extending the entrance of the gallery farther east. The Outer Lanzón episode was then constructed, extending the gallery entrance further east and to the south.

Whether the Inner Lanzón Chamber and the Middle Lanzón were built at the same time is unclear; they were abutted to opposite sides of the entrance to the Inner Lanzón Rectangle, and thus have no apparent direct chronological relationship. The Inner Lanzón Chamber likely was completed either before or with the construction of the Middle Lanzón episode. This is because the form of the Middle Lanzón episode suggests that it was surrounded by fill, which in turn suggests that the Inner Lanzón Chamber likely was completed and surrounded by fill by the time the construction of the Middle Lanzón episode was complete. I hypothesize that, rather than the Inner Lanzón Rectangle being covered by the construction of the Inner Lanzón Chamber prior to the construction of the small Middle Lanzón, the Inner Lanzón Chamber and the Middle Lanzón were built simultaneously, as one effort, to transform the Inner Lanzón Rectangle into a gallery:

the rectangle is roofed, the entrance is extended to the east, and the structure is surrounded by fill. This hypothesis suggests that the Lanzón Gallery was built in three episodes--Inner Lanzón Rectangle, Inner Lanzón Chamber-Middle Lanzón, Outer Lanzón -- rather than four. In either case, by the end of the Middle Lanzón episode, the transformation of the Inner Lanzón Rectangle from likely a free-standing open structure to an integrated part of an internal gallery is complete.

Gallery VIII

Gallery VIII was located directly above the Inner Lanzón Chamber. It was largely destroyed by the aluvi3n of 1945: Rowe (ms.b:93) noted approximately 40 cm of the walls of part of Gallery VIII remained, buried, after the landslide. Drawings and descriptions in Tello (1960:Fig, 17, Figure 19, 109) from before the aluvi3n, however, enable the gallery to be reconstructed in CAD (Figures 3.205 - 3.207), and thus its spatial relationships with other elements to be analyzed.

Gallery VIII appears to have stood 1.80 m high and to have contained three north-south segments connected by a central east-west segment (Tello 1960:Fig, 17, Figure 19, 109). Tello (1960: Figure 17, 109) notes that vents extend to the east and west, and that its east vent measured 70cm x 70cm and extended 11.90m towards the east face of Building B. The location of the entrance to Gallery VIII is unclear. One of Tello's sketches (1960:Figure 17) suggests possible collapse in the south extreme of the eastern east-west passage and in the north extreme of the middle east-west passage; perhaps one of these extremes held an entrance to the gallery.

Gallery VIII is similar in size to the Inner Lanz3n Chamber directly beneath it. It is possible that Gallery VIII at some point may have been a free-standing rectangular structure, open or covered, similar in form and size to the Inner Lanz3n Rectangle and the free-standing rectangular structures atop Building A.

The Mirador Gallery and The Loco Gallery

Mirador and Loco are located in the north-central portion of Building C (Figures 3.208 - 3.211). Because Mirador was connected to Loco via gallery segments to the north of their present areas, as discussed below, the two galleries are presented here together. They were built in four episodes (Figures 3.212 - 3.215) some of unusual construction indicating much modification to the gallery over time. These episodes exhibit many of the construction patterns seen in galleries examined thus far.

Construction of Mirador

Mirador contains consistent stonework and no apparent seams, indicating it was built in one episode. Its walls are built of irregularly shaped stones of varying sizes, large to small, in poorly defined courses surrounded by heavy mortar (Figures 3.216, 3.217).

Remnants of former passageways exist outside Mirador and Loco, including the walls that connect their present entrances (Figures 3.218 - 3.224). These indicate that the galleries at one time were connected. Tello (1960: Figure 9, 110-111), prior to the aluvión of 1945, documented them not only as connected, but also extending further to the north to a gallery patio that had three gallery entrances; this patio is referred to here as the Loco Patio. This connection between the galleries via the outer segments as well as similar stonework in the north segment of Loco suggest that Mirador was built at the same time as the northernmost segment of Loco, discussed further below. The galleries connect via vents as well; a vent connects the west wall in Mirador to Loco and continues out the west Loco wall to what is now collapse, but originally may have been a gallery segment to the west (or to the outside).

Points shot on the exterior remnants of the gallery segments include a small corner to the west of the Loco Gallery. This corner is symmetrical to the east corner of the exterior remains.

This suggests that Tello's drawn reconstruction of this area is valid, and that a west counterpart to Mirador could have existed.

Loco

Numerous seams exist in Loco. The gallery contains a large amount of fill, particularly in the west area where most of the seams are situated. The bottom portions of these seams are buried, but the tops provide enough clear information about their construction to be considered reliable evidence regarding the construction history of this gallery.

Seam at the Intersection of Segments B and S: Loc-B-1

One of these seams, Loc-B-1, is located in the west end of Segment B, just east of the intersection with and "doorway" to Segment S (Figure 3.225). The stonework of the seam indicates that the west side was built before the east side. On the north portion of the seam, Loc-B-1-n, the straight edge of the wall west of the seam and the small stones in the rougher wall east of the seam suggest that the east side was abutted to the west (Figure 3.226). On the south portion of the seam, Loc-B-1-s, the wall west of the seam also is very straight, with the wall east of the seam less straight but with no small stones remaining between the edges to indicate clearly the direction of abutment. Above this, however, the beam from the east overlaps the top of the doorway lintel to west; indicating that the doorway likely was there first (Figure 3.227). The stonework on either side of the seams differs, with smaller and more compactly placed stones to the west of the seam, and larger stones to the east of the seam; additionally, the courses do not align (Figures 3.228, 3.229). This seam indicates that Segment S was built before Segment B.

Seam at the north end of Segment L, east wall: Loc-L-1

Another seam, Loc-L-1, exists in the north end of Segment L, on the east wall (Figure 3.230). The seam continues up between ceiling beams. Small chinking-type stones on the south

side and a straighter edge on the north side of the seam suggest that the north side was built first and the south side later was abutted to it (Figure 3.231, 3.232). The coursing is not aligned across the north and the south sides of the seam, and the stonework on the south is slightly larger than that on the north.

No seam exists on the west wall of Segment L opposite the Loc-L-1 (Figure 3.233, 3.234). The stonework, although somewhat irregular, appears original and built in one episode. The stonework consists of larger stones similar to those on the south side of the seam on the east wall.

Seam at the west end of Segment P: Loc-P-1

Seam Loc-P-1 lies in the west of Segment P, just east of the intersection with Segment R (Figure 3.235). On the north side, small stones from the east overlap the seam, suggesting an abutment of the east side against the west (Figure 3.236). The small stones to the east of the beam, west of the seam, are not weightbearing, and may have been added with the abutment of the east wall. Additionally, the north side has a “column” of stones to the east of the seam, as if only stones of a certain size would fit here (Figure 3.237): this supports R being built first. The stonework is different between the two sides; to the west of the seam the column under the doorway lintel contains smaller stones, stacked to create a straight edge, while to the east of the seam the stones vary more in size, with small and large stones with relaxed coursing. The coursing on the two sides does not align. On the south wall, the building order of the seam is less clear, with no stones clearly overlapping the seam and thus indicating the order of abutment (Figure 3.238). The column under the doorway lintel also has stones smaller than the larger ones to the east of the seam, and again the beam does not come up to the edge of the column, rather the column extends east with stones that do not hold the weight of the column and could have been added after the abutment (Figure 3.239). While not conclusive, the north wall evidence suggesting that the west side of the seam was built first likely carries over to the south wall,

assuming that both sides had to have been built at the same time to support the doorway lintel that spans them. Overall, the analysis of this seam suggests that the west side and Segment R were built first, followed by the east side and Segment P.

Presently Segment R is filled with rubble, but its east-west running beams are evident, supported by the door beam (Figure 3.240). It is unusual in a narrow short segment like this to have beams run perpendicular rather than parallel to a doorway; similar beams occur in Segment Q, where they collapsed.

Seam at the east end of Segment P: Loc-P-2

In the east end of Segment P, on the north wall just west of Segment Q, lies another seam -- Loc-P-2 (Figure 3.241). The stonework is very unstable, including collapsed beams in Segment Q (Figure 3.242), in great contrast to the intact beams in Segment R. The coursing on either side of the seam does not align, and the stonework on the west side is larger than that on the east, but the stonework does not clearly indicate which side was abutted. Chronological information does appear in the construction of the ceiling, however. After the walls were abutted, forming the seam, overlapping ceiling beams were placed in a very unusual pattern, running east-west perpendicular to and resting on the Segment Q doorway lintel, parallel to the north wall (Figures 3.243 - 3.245). The big beam parallel to the north wall in Segment P suggests that the north wall did not exist first, because if nothing stood to the east, in order to roof P the beams would need to run N-S. The fact it runs E-W and rests on the doorway lintel to Segment Q suggests that the doorway lintel to Segment Q existed first, meaning Segment Q was built before Segment P.

No seam exists directly to the south of this seam, because the seam itself aligns directly with the east wall of Segment L, where Segment L intersects Segment P.

Seam at the south end of Segment L: Loc-L-2

A seam, Loc-L-2, may be apparent on the east wall of the south end of Segment L. The seam is not clear because aluvión still covers the stonework, keeping it from being clearly observed, and because the area appears to have been partially reconstructed, likely in the excavation and reparation work by Diessl (1989). In the area underneath the raised beam towards the south end of the hallway, approximately at the equivalent location of the seam in the north end of Segment L, the wall is obscured by mud or aluvión on wall (Figures 3.246 - 3.249). North of this area the east wall is built of large stones. South of this area the stonework is much smaller, with smaller courses that do not align with the large courses to the north. The aluvión or mud between these two areas makes the presence of a seam unclear. It appears that some stones may cross this area of aluvión cover. Evidence of rebuilding also obscures the wall's construction; the beam at the south of Segment L, crossing Segment M in front of Segment N, appears to be hidden in the wall of Segment L. The stonework in this area appears to have been rebuilt. Overall, the stonework changes between the north and south portions of the wall suggest that there could have been a seam there, particularly when compared with the similar pattern in the south end of Segment L. It is expected that a seam here would indicate that south portion of the east wall of Segment L was built before the north portion.

No seam is apparent on the west wall of the segment opposite the east area (Figures 3.250 - 3.252), echoing the construction of the north end of the Segment L. This wall contains the same stonework as the area to the north of the aluvión area in the south end of Segment L.

Seam at the east end of Segment M: Loc-M-1

In the east end of Segment M, seam Loc-M-1 is located on the south wall directly east of the east wall of Segment L (Figure 3.253). This area has undergone partial reconstruction by Diessl (1989). The visible construction evidence suggests that the east side of the seam was built before the west side of seam. The top of the seam is covered by aluvión (Figure 3.254), but the

lower part of the seam is clear, with a straight edge and neatly laid compact courses of small rectangular stones on the east, and small stones in the bottom third on the west, in courses of larger, less regular stonework, indicating the west was abutted against the east side of the seam (Figure 3.255). Also, the ceiling beams run east-west over the doorway lintel, covering the hallway space, suggesting that the doorway lintel had to have been placed before the hallway, and thus that the east side of the seam was built before the west side. The vent in the south wall suggests it was built into a closed space and that the west side of the seam was built later than the east side. This evidence indicates Segment N likely was built before Segment M.

Seam at the west end of Segment M: Loc-M-2

In the west end of Segment M, seam Loc-M-2 is located just east of Segment O. The north wall's stonework indicates the west side of the seam was built before the east side of the seam. The west side has a straight edge against which small stones from the east cross the seam, suggesting the east was abutted to the west. The stonework on the west is small, more orderly, and compact (as is the stonework in Segment O), while to the east the stonework is larger and less orderly, and the courses do not align across the seam (Figures 3.256, 3.257). On the south wall, the stonework and abutment pattern is the same as on the north, indicating again the east side abuts the west (Figures 3.258, 3.259). Thus the architectural evidence indicates that Segment O was built before Segment M.

Segment S

Segment S, located at the west end of Segment B (see Figure 3.225 above), has a number of interesting areas. First, behind the central "column" support (Figure 3.260) lies a clear end wall seam, Loc-S-1, with the column abutted against the west wall (Figures 3.261, 3.262). The stonework of the column is similar to the end wall.

Second, Segment S contains three unusual “zig-zag” lines. In the west wall of the north branch of Segment S, a vertical “zig-zag” line is clearly marked by uneven coursing (Figure 3.263). In the south branch, a zig-zag line also appears, marked by the stone courses not aligning (Figure 3.264), although the collapsed stones and rubble obscure a full view of it. The south wall near the southeast corner has another zig-zag line (Figure 3.265). In the north wall this area has collapsed so it is unclear whether such a feature existed here as well (Figure 3.266). Both sides of these seams likely were built at one time: stones overlap, despite mis-aligned courses. This suggests the walls containing these seams were built at once, using a different building method; these “zig-zag” lines appear to be a construction technique rather than a chronological seam. They may result from walls being built from opposite directions until they met, creating courses that did not align but were made to fit as best as possible at these “zig-zag” lines.

Third, a possible end wall seam exists in the northwest corner of S, in which the larger stonework of the north wall appears to go behind the smaller stonework of the west wall (Figures 3.267, 3.263 above). The southwest corner of S is partially collapsed and obscured, but the stones on the south wall appear to be bigger than those on the west wall (Figures 3.268, 3.264). If these were seams, this would imply that the room originally was open to the west, or the south and north walls were built without bonding.

In Segment S, a square room appears to have preceded the column, which preceded the present ceiling. Segment S could have been built in one episode, even if the construction is disjointed and not smoothly integrated between and within walls. It could also originally have been a small open rectangular structure or room, with the column and ceiling beams added later. The reason for the unusual building methods evident in this segment, particularly the column supporting the ceiling beams, and the zigzag lines, is unclear.

Axis shift

The primary architectural axis of Mirador and the north part of Loco differs from that of south Loco. The axis shift occurs in Segment A, near the vent to Segment K on west wall (see Figures 3.208, 3.211 above). South of these points, Segment A veers to the west. North of these points, Segment A veers to the north.

Stonework changes in the gallery correspond with the axis shift, as far as can be seen given reconstruction of this area by Gonzáles (Gonzáles and Rick video interviews, 1995-1998). Mirador, the outer segments, and the north part of Segment A in Loco contain the same large stonework, which continues south until the area near the big beam over Lower Loco. South of this in Segment A, the stonework is much smaller. A formal seam does not exist between these areas; Segment A has been consolidated by Gonzáles in many places, including the here at the west wall of Segment A between Segments D and B, and at the vent to Segment K from Segment A, where a patched area extends diagonally down to the south. The reconstruction of the stonework in this area thus covers the area in which a visible seam might have existed. The reconstruction could account for some of the shift in axis but not all of it, because Mirador and the outer segments are differently aligned as well, and they have no signs of consolidation or late alteration. The consolidated stonework does appear to follow the directions of the walls into which it was integrated.

Taken as a whole, Segment A appears to contain transitions between both different axis alignments and different stonework somewhere between the top of the Lower Loco stairs and the area just south of the AE intersection. It is hard to pinpoint an area in the stonework, partly due to Marino reconstructions, so the shift is more of a gradient transition rather than an abrupt point or seam.

These shifts in stonework and alignment axes suggest that Mirador and the north part of Loco were built separately from south Loco, the area south of Lower Loco. Whether the switch

from one alignment to the other was deliberate rather than incidental in unclear; it may have been due to a need to align the north portion of Segment A over Lower Loco.

Lower Loco: Loc-A-1-Hz

Lower Loco is located in the north end of Segment A in Loco (Figure 3.269), presently spanned by boards. In Lower Loco, steps descend below the current floor level of Upper Loco. At the current base of the excavation the walls indicate that the gallery turns west and continues underneath the west wall of Segment A. According to Marino Gonzáles (Gonzáles and Rick video interviews, 1995-1998), the excavation stopped for fear of collapse before reaching the base of the stairs, and the steps continue down into the fill. This implies that the original floor level of Lower Loco was lower than the base of the excavation. Thick plaster covers the walls and steps. Burial likely preserved the plaster, which provides more evidence that the galleries were plastered and thus that the stonework of the gallery walls likely was not visible.

It is unclear whether or not Lower Loco was originally roofed, and how or if it was covered when Upper Loco was built (Figures 3.270, 3.271). The north “ledge” is primarily dirt. Corbel-type stones exist over the south end, but do not jut out over the stairs and actually sit above floor level of the Upper Loco, although there may have been space for removed beams to sit. If ceiling beams spanned Lower Loco here originally, they do not appear to have followed the stepped pattern characteristic of ceilings over stairs. The straight edges of the top of the Lower Loco walls thus suggest that these walls originally supported ceiling beams that spanned Lower Loco, or were open; the flat wall tops suggest that any ceiling over Lower Loco was originally flat, not stepped. The lack of outlines of a stepped ceiling here suggests that Lower Loco did not originally contain a staircase but rather was a straight hallway segment to which stairs were added, likely at the time Upper Loco was built, to connect Lower and Upper Loco. The fact that the top step is much taller than the others, making the stairs uneven and atypical of Chavín steps, is consistent with this scenario. Alternatively, the stairs may have been original but stood open,

leading to a gallery or part of a hanging staircase opening to the north, with the appropriate turn at the bottom landing; these alternatives, however, do not conform with the stair construction principles used at Chavín. The stairs thus suggest that access was maintained between the two, and that Lower Loco was not filled in to support Upper Loco. How the opening to Lower Loco was spanned, and why Upper Loco was built directly over Lower Loco, are unclear.

What is clear, and most relevant here, however, is that Lower Loco was built before Upper Loco, and the Upper Loco was added on top of Lower Loco, at the horizontal seam Loc-A-1-Hz.

South Loco

The stonework in the remainder of the south part of the gallery is largely similar to that in the segments connecting the square segments to the west, consisting of med-large stones in rough but clear coursing, mixed with small chinking stones. Together these are called "South Loco." Some areas are consolidated by Gonzáles (Gonzáles and Rick video interviews, 1995-1998) but these usually contain stonework distinct from the original stonework, comprised of smaller stones laid with much mortar. Segment G contains a couple of corbels, but otherwise the stonework is similar to that in IJK suggesting this is not exterior stonework of an early Building C exterior wall.

This stonework differs from the stonework in the north part of Segment A, in Mirador, and in the exposed segments between the two galleries, or the area here called North Loco. The stonework in North Loco is comprised of larger stones, with less regular coursing, than in South Loco, (Figures 3.272 - 3.274, 3.218 above, 3.219 above, 3.223 above). As mentioned in discussing the axis, above, the transition seems to occur mid-Segment A, in the area near the lowered beam in A near Segments C and D, just south of the top of the stairs to Lower Loco. North Loco and South Loco also have different ceiling levels, transitioning in the area near the

large lowered beam in A near Segments C and D. Thus, North and South Loco are distinguished by different ceiling levels, a shift in axis, and a shift in stonework.

Construction history

Four main construction episodes in Loco have been identified above; 1: Lower Loco; 2: Loco Rooms (Segments S, N, O, Q, and R separated by seams in the west end of Loco); 3: South Loco (Loco south of stairs, east of Rooms, and connecting Rooms); 4: North Loco (North Loco, exterior segments, and Mirador). The following chronological relationships between these episodes are clear: Lower Loco must be before Outer Loco, because it is below Outer Loco. Loco Rooms must be before South Loco, because of the seam chronologies. South Loco could be before, same time, or after Lower Loco. South is before or possibly at the same time as Outer Loco. Lower Loco could be before, at the same time, or after Loco Rooms.

The most plausible sequence for their construction is the following: first, Lower Loco was built, as either a gallery completely enclosed in this area, or possibly as open stairs in the top of a platform leading down to a gallery segment that turns west. Then on top of the platform containing Lower Loco the Loco Rooms was built. Later, South Loco was built, connecting the Loco Rooms and creating the seams at the doorways to the Rooms. North Loco was then built, with a lower ceiling, different stonework, and an shifted from the South Loco axis but aligned with the axis of Lower Loco. North Loco was built over Lower Loco and they were connected with stairs, and a way to span it must have been created. From the exterior, according to Tello (1960), North Loco was not entered via descending stairs, but rather from a gallery patio to the north that contained three entrances into Building C.

Segments S, N, O, Q, and R, built during the Loco Rooms episode, originally likely were free-standing rectangular structures. Whether they were roofed or left uncovered is not clear. It is possible they were covered and not freestanding, like rooms in a building, each with exterior openings; however, the fact that they did not originally connect with walls between them is

inconsistent with this possibility. It is interesting to note that the visible portions of these rooms do not contain vents.

The Marino Gonzáles Staircase

The Marino Gonzáles Staircase is located on the west face of Building A, near the Laberintos Gallery. It is a large staircase covered with a stepped ceiling. Some of the ceiling beams in the west end of the staircase have fallen, creating gaps in the ceiling (Figures 3.275 - 3.279). The staircase connects the current ground level with the top of Building A.

Level 1 evidence indicates that the Marino Gonzáles Staircase was built in one episode (Figures 3.280, 3.281). No seams or differences in the stonework are evident. The stonework is consistent throughout the gallery, comprised of mostly large stones, with some medium stones and small chinking (Figure 3.282).

Analysis suggests that this staircase originally did not open to foundation or ground level, but was a hanging staircase in the west face of the temple, which is currently largely buried in fill. The present entrance to the staircase, where stone steps disappearing into a dirt landing, suggests that the original entrance level of the Marino Gonzáles Staircase is buried. In the CAD model, when the slope of the staircase is continued west down from the lowest visible step, the stairs meet the exterior wall 2.16 meters below the present entrance floor. This suggests that the floor of the original entrance sat near this level. If the stairs do not continue down, the entrance would be located even higher. In either case, the stairs do not descend to ground level or the foundation of Building A, indicating that the gallery likely was a hanging staircase.

The top of the staircase was modified recently. As part of these modifications, a ladder climbs to the surface through a gap between ceiling beams (Figure 3.283). With the modifications, the history of the area is not clear. However, Rowe (ms.b:94-95) noted that

“the stairway approaches the surface but then is broken and blocked; the closing probably took place in antiquity, as there is a curved wall corresponding to a post-Chavín

("Huaylas") occupation over the top of the stairs and a square tomb built against the door at a time when it had been partly filled in. At the head of the stairs is a deep treasure hunter's hole, evidently dug in from the stairs rather than from the upper surface of the mound."

This suggests that the staircase was originally open in Chavín times.

The walls of the Marino Gonzáles staircase exhibit batter. The south wall is more battered than the north wall. This is significant, indicating that, like in Escalinata, tall interior walls contain batter.

Summary

The consistent stonework and the lack of seams in the Marino Gonzáles Staircase suggest it was built in one episode. It contains the stepped ceiling characteristic of staircases at Chavín, with no corbels. Its walls exhibit batter characteristic of tall walls, whether exterior or interior, at Chavín. It differs from other staircases in that it apparently descended straight out the building and contained no landings, rather than bending at ninety degrees and containing one or more landings, as most of the other staircases do.

The Murciélagos Gallery

The Murciélagos Gallery is located in the west side of central Building A. It is currently entered from the Cautivos Gallery (Figures 3.284 - 3.286). The ceiling over the staircase descending from the entrance is stepped and is not supported by corbels (Figures 3.287, 3.288). The gallery's stonework consists of large-medium stones with chinking and clear coursing (Figure 3.289), although some of the walls, taller here than in most galleries are greatly deteriorated by severe bowing (Figures 3.290 - 3.292).

No seams are evident in Murciélagos, indicating the gallery was built in one episode (Figure 3.293). Two end walls (Segments B and C) are partially obscured by rockpiles, but the portions that are visible suggest no seams exist. The area just inside the entrance from Cautivos

(Figure 3.294) contains some features typical of seams, but evidence of overlapping stonework indicates these rather are remnants of construction technique and no seams exist here either.

Murciélagos contains many unusual features and characteristics that are highly variable in form. First, the gallery contains many exterior and interior vents; in addition to a vent at the end of each side segment, double rows of now-collapsed stacked vents interconnect the side segments, and a vent in the center of the Murciélagos staircase (Figure 3.295) trends south east out of the gallery. Second, the segments in this gallery are not orthogonal to each other, the angle of the main hallway changes at the stairs, and the whole gallery itself is skewed with respect to the architectural alignment of the site. Third, Segment C has a step and raised floor (Figure 3.296), very unusual gallery features. Explanations of these features and characteristics become clearer with the Levels 2 and 3 analysis below, where they enter into the analysis of Murciélagos' relationships with other internal spaces and the exterior.

Summary

In Murciélagos, the consistent stonework and the lack of seams indicate the gallery was built in one episode. A stepped ceiling covers the entrance stairs, which descend into the gallery. The staircase contains no corbels. It contains many features unique to the gallery, features that take on greater meaning when examined in the light of their relationships to other galleries and site-wide patterns.

The Cautivos Gallery

The Cautivos Gallery is located in the west side of central Building A (Figures 3.297 - 3.299). It is entered through a descending staircase from the top of Building A. Construction evidence suggests was built in one episode, abutting against an earlier wall to the north containing the entrance to Murciélagos (Figure 3.300).

The stonework of this north wall is much different from the rest of the gallery. Its stones are very large, much larger than the stonework in the rest of the gallery, with well-laid chinking between the stones (Figures 3.301, 3.302). The north wall stones are comparable to exterior stones in size and quality. The north wall continues past the modern entrance gate to the east, where the entrance steps are laid in front of it. This evidence indicates Cautivos is abutted against an external wall containing the entrance to Murciélagos, which then became the north wall of Cautivos. Lumbreras and Amat (1965-1966:148, 160) noted this difference in stonework as well, stating that Cautivos was abutted against the south wall of the Old Temple.

The north wall contains evidence of how Cautivos was built up against it. New constructions appear to have been added to the top of the north wall during the construction of Cautivos, creating a horizontal seam (Cau-A-1-Hz) marked by a course of pegs and a coursing change. The pegs sit directly on top of the extremely large stones and surrounding chinking of the former external wall (Figures 3.303, 3.304). They are irregularly placed on top of the large courses, with much mortar, and are covered with a thin course of small stones that support the ceiling beams, which unusually slant down from this wall to the south. These pegs begin just west of the bottom of the staircase and continue west down the length of the main hall. East of the pegs, the stones in the peg course and the courses above it are smaller than the large stones below the peg course, and continue east into the gallery stairs. The large north wall stones also continue east past the entrance and appear original up to the second step from the top (Figures 3.305 - 3.308). This evidence suggests that the pegs and the additional course to support the ceiling were not original to the external wall, but were added at the time of the building of Cautivos: the pegs mark a horizontal seam at the abutment of Cautivos to the external wall of Murciélagos.

This horizontal abutment implies that the course below the pegs, at the top of the doorway lintel of the Murciélagos entrance, marks either the maximum height of the external wall before Cautivos, or the level to which a higher external wall was deconstructed to accommodate the new gallery and to which the pegs and the ceiling courses were added. If the wall had

continued higher, the gallery could just have been abutted against it, as in Columnas-Vigas. However, the long east-west main hallway parallel to the north wall necessitates ceiling beams that must rest on the north wall; it is unclear within the gallery whether it was designed this way to take advantage of a low north wall, or whether a higher north wall was deconstructed to conform to the desired gallery form and/or to accommodate the peg feature. The pegs do not have a structural function like corbels, as indicated by the fact they do not support the ceiling.

No other seams are apparent in the gallery. The south walls contain vents that are blocked soon after they exit the gallery, and the west walls contain vents that were built by Marino as part of a reconstruction of the west end of the gallery, which Tello (1960:112) had found collapsed and open to the west. Pegs and variations on pegs line the halls (Figures 3.309 - 3.311).

Summary

Cautivos likely was built in a single episode, abutting against the former south-facing exterior wall containing the entrance to Murciélagos. A horizontal seam lies between the top of the former exterior wall and a course of pegs added with the construction of Cautivos, possibly involving major modifications to the north wall. The stonework between the older north wall and the added gallery is drastically different. Cautivos is entered via a descending staircase, the ceiling of which appears to have been destroyed. The construction of Cautivos against the exterior wall resulted in Murciélagos being accessed only via Cautivos. The stairs between Cautivos and Murciélagos connect two different construction episodes.

Gallery XIII

Tello named and documented Gallery XIII, drawing an elevation view of the gallery (Tello 1960:Figure 9., 112-113, Figure 22). Gallery XIII lies north of Cautivos and west of Murciélagos (Figures 3.312 - 3.314). The gallery is currently entered from the north wall of

Cautivos, the former exterior wall, through what appears originally to have been a vent extending south that has since been widened (Figure 3.315). The west wall of this vent appears intact, but the east wall and part of the ceiling have collapsed or been torn out (Figure 3.316). If this vent was original to this wall, built with Murciélagos before Cautivos, it originally would have opened to the exterior.

Inside the gallery, a vertical shaft meets a sloped floor descending to the west. The vertical shaft measures approximately 45cm x 45cm, and is formed of flat-faced rectangular stones stacked neatly with little chinking, with one stone per course. The shaft falls approximately 3.90 m from its rubble-plugged top to the vent at which one enters (Figure 3.317), and then falls approximately 1.85 m to the sloped bottom (Figure 3.318), where it opens and descends to the west. The area that can be seen was built in one episode; no seams are evident, and it to be a functional unit.

My team and I could not confirm the layout shown in the Tello's (1960:Figure 22) section sketch, because it includes much more than we could see in this narrow shaft. The location of the present entrance does concur with a vent shown in Tello's drawing. One vent that would correspond with the top vent shown in the drawing exists in the rubble fill of the west face (Figures 3.319).

The Liticos Gallery

The Liticos Gallery (also known as La Galería de las Piedras Labradas) is located near the center of Building A (Figures 3.320 - 3.322). It contains two levels connected by a staircase. A possible horizontal seam at the top of this staircase suggests the gallery could have been built in two episodes (Figure 3.323). The gallery follows many of the building patterns seen in other galleries, and contains a number of features indicating the use of various construction methods.

Evidence of horizontal seam in stairwell

In Liticos a subtle but clear transition in stonework occurs beneath the top three courses of the stairwell leading down to the lower level of the gallery. Below this line the stairwell walls are built of loosely coursed, small, rough stones, approximately 15-20cm x 15-20 cm (Figures 3.324 - 3.327). The three courses above this line are better coursed and built of larger, more rectangular rocks than the rest of the stairwell. The stonework above the transition is well-coursed in most areas, made of medium (30x15cm) and some large (80x20cm) rectangular stones, most of which are framed by small chinking stones (Figure 3.328) while below the transition the small stonework continues, with large thick beams, in Segment I and (Figures 3.329, 3.330) into Segment J (Figures 3.331, 3.332), where it becomes larger, with clearer but still loose coursing containing heavy mortar and little chinking in some areas. This stonework transition in the stairwell suggests that a horizontal seam (Lit-K-1-Hz) exists here. This evidence for a horizontal seam divides the gallery into two episodes, Lower and Upper Liticos, and is reexamined in the Levels 2-3 analysis.

A stepped ceiling covers the stairs, which atypically terminate between approximately 0.3 and 0.8 m above floor level in lower Liticos Seg I. The explanation for this is unknown.

Half Seams

Two "half-seams," or seam-like features below vents, are present in Upper Liticos, one in Segment D (Figure 3.333) and one in Segment H (Figure 3.334). On each, the slope of the seam indicates the right side was built first. It is not clear what they represent, but they appear to be evidence of construction technique rather than evidence of chronology.

Abutment as construction technique

In Segments A (Figure 3.335) and D (Figure 3.336), abutments in two corners appear to be result of only construction techniques rather than of chronological seams. The abutment

evidence does not continue through to the opposite walls, and the stonework of both sides of the abutments is the same.

Transition between Upper and Lower Liticos

The northwest corner of Segment B, at the top of the stairs between Upper and Lower Liticos, is unusual. First, on the north wall, a strip of stones aligned with a sharp straight edge continues up to two courses below the corbels. West of this strip, stones have fallen from the wall (Figures 3.337 - 3.339). At first it looks like the area of fallen stones west of the straight edge could be a filled-in door or niche or steps. However, no beam exists over the top of the area as would be expected if it had been an open space, nothing spans the space except the corbel, and the north wall stones seem to bond with west wall, although this is not completely clear. It therefore does not appear that this area originally was open. No clear chronological significance is evident at this point.

Second, the stairs to Lower Liticos and the niche above the stairs are not centered in the west wall of Segment B (Figure 3.340); this is very unusual. The beams over the stairs and the niche are approximately the same width, as if they were placed to be centered, but they are off-center and slightly covered on their north ends by the north wall. The stonework in the northwest corner is not clear, along with the chronological implications of this area.

Summary

A change in stonework at the top of the stairs in the Liticos Gallery suggests a horizontal seam is present, separating this gallery into two episodes, Upper and Lower Liticos. This conclusion is readdressed in the next chapter, after analyzing its relationships with other galleries and the exterior. Both Upper and Lower Liticos are entered via descending staircases covered with stepped ceilings, neither of which contain corbels, although corbels do exist in other

segments of the gallery. Half seams and a number of other unusual features are present, but their chronological implications currently are not clear.

The Columnas-Vigas Gallery

The Columnas Gallery and the Vigas Ornamentales Room are located in the east side of the center of Building A (Figures 3.341 - 3.344). The Vigas Ornamentales Room is located within the larger Columnas Gallery, and therefore they are addressed here together and called the Columnas-Vigas Gallery. Evidence indicates it was built in two primary episodes (Figure 3.345). Analysis of the Columnas-Vigas Gallery contributes to understanding how galleries were accessed, how new episodes were added, the significance of interior plaster, and the significance of varying quality of stonework within the gallery. It contains some of the best extant evidence for the construction of gallery patios.

Seams along the north wall

Clear end wall seams exist on the north wall of the gallery; these seams are identified as Col-A-1, Col-C-1, Col-E-1, Col-H-1, Col-N-1, Col-P-1, and Col-R-1. At these seams, the north wall continues behind each of the abutting side walls, and in each segment the north wall stonework is the same, with large, well-coursed stones and regular chinking. The stonework in the side walls is smaller with more irregular coursing and chinking (Figure 3.346). The stones of the top courses of the north wall clearly rise higher above the beams, which do not sit directly on the end walls but on sidewall corbels in front of them. The stonework of the north wall suggests that it was an exterior wall that extended higher than the top of the gallery, and that the north segments of Columnas-Vigas later were built abutted to it. Rowe (ms.a:95) and Lumbreras and Amat (1965-1966:148, 158) observed this abutment and concluded that the north wall was a former exterior wall.

The north former exterior wall and the gallery continue east to the point where they were destroyed by one of the large historic-period trenches in the east temple, opening the gallery directly to the east (Figure 3.347). Collapsed stones at this entrance indicate another internal gallery segment, Segment A, existed here with the same construction and shape as the segment immediately to the west, Segment C. Like the other gallery segments, the side walls of Segment A are constructed of smaller stonework than the north wall, and abut its large stonework (Figures 3.348, 3.349).

In the west end of the gallery, Segment R, the north wall extends behind the west wall, as it does in the rest of the gallery (Figure 3.350). The west wall, however, is constructed more similarly to the north wall than to the rest of the segment and north-south walls in other segments (Figure 3.351). Also, the stonework and coursing on the south wall is much different than the east or west walls, which appear to run behind the south wall (Figures 3.352 - 3.354). The ceiling construction is well integrated, however, although the beams don't continue across the south wall. This segment has a strange mix of constructions. On the whole, it appears that the west wall of Segment R was built after the north wall yet before the rest of the segment and the rest of the gallery. The south wall may have been added after the west and east walls, but before the segment was roofed.

Seam with plaster in Segment E: Col-E-2

Col-E-2 is a seam containing red plaster that lies in the east wall of Segment E (Figures 3.355 - 3.357), opposite the south wall of Segment F and the south walls of Segments C and A (Figures 3.358, 3.359). The presence of plaster in the seam suggests that the two sides of the seam were constructed at significantly different times. Although the top of the seam leans slightly to the north, the stonework indicates that the south side of the seam was constructed first (Figures 3.355 above, 3.360, 3.361). The regular courses on the south side of the seam form a straight edge, creating a slight "column" seen in other walls (ie across the hall, Liticos Rm D). The

stonework on the north side is less regular, with small stones placed up against the seam, indicating this wall was abutted to the south wall.

Changes in the corbel layer also suggest the south and north sides of the seam were built at different times. The ceiling and corbels are higher over the seam and to the north of the seam than they are south of the seam. Differences in corbel size between north and south sections also support this: to the south of the modified area they are smaller and evenly sized (Figures 3.357 above, 3.362 - 3.365, 3.355 above, 3.358 above); in the modified area and to the north of it, they are larger and unevenly sized (Figures 3.366 - 3.370).

However, a corbel crosses the top of the seam (See Figures 3.355 above, 3.371, 3.372). This implies either that the south side of the seam, covered with plaster, stood open until the north side was abutted to it and they were both covered, or that the south wall originally contained a different corbel here. An original different corbel likely would have aligned with the seam, then when the north wall was abutted the original corbel would have been replaced with the corbel that now spans the seam. A number of factors suggest the latter explanation is more likely. The ceiling beams do align with the seam, likely due to its alignment with the opposite door, suggesting the beam just south of the seam could have been in place before the north addition. Across the hall the doorway lintel blocks the top of the wall opposite the seam; this also suggests the south could have been covered first.

Together, the architecture in Segment E suggests that the south side of the seam was built first and covered originally. The corbel and beam area around the seam were lifted and relaid to accommodate the addition of the north side of the seam and the rest of the segment to the north, as well as the beam running north-south over the east end of Segment F. The corbel level was raised and continued in the new construction north of the seam.

Because the south side was built first, the fact that no end wall seams exist in the south ends of segment C suggests the wall east from the Segment E seam did not extend far east, but stopped just east of Segment E.

Columns

Two pairs of columns exist in the gallery, a west pair between Segments N and P (Figure 3.373), and an east pair between Segments N and H. The columns are approximately 1.65 m in diameter, and are built of rough stonework. The columns are structural, supporting the ceiling beams in each segment. A very large beam spans the west columns (Figure 3.374); this beam in turn supports the corbels ceiling beams over these columns. Stonework fills the space between these columns and between the north column and the north wall. In the east pair there is no beam over the columns, rather the columns and stonework fill between them directly support the corbels (Figure 3.375).

Why a beam spans the west columns and not the east is unclear. The beam over the west columns possibly could have been there before the columns were covered and the space between them was filled, serving a purpose other than supporting the ceiling stonework. A beam could have been removed from east, or perhaps it never had one. This will be addressed more in Chapter 7.

Doorway by Columns

Although the entrance between Segment N and Segment I is presently collapsed, the stonework here suggests that the area north of the south wall of Segment I was originally open, and that to cover it the stonework above the south wall was modified. The top of the southwest corner of Segment I looks as if it was deconstructed to accommodate a large north-south beam placed here to span Segment I across to the south column. These modifications are similar to those done in Segment E and the east end of Segment F, discussed above. The door beam has cracked and the overlying layers have collapsed, but the construction evidence is still discernable. South of the intersection of Segments N and I, the corbels on the east wall shift from single-layered to two-layered. (Figures 3.376 - 3.380). The lower of these two courses contains large

similar to the corbels to the south. At the south edge of the door frame, however, the higher course becomes the large corbel layer and the lower course becomes “filler” between the door beam and the corbels. Over the door beam the lower course is coplanar with the face of the door beam, and the higher course is an overhanging corbel. South of this, the lower course becomes the main corbel and the higher course becomes smaller, like filler, but is in the same plane as the corbel, not the wall. These differences from the single corbel construction to the south support the idea that the south half of Segment N originally was covered, while the area north of the south wall of Segment I, as well as Segment I, was originally open, and the top of the southwest corner of Segment I was deconstructed to accommodate a beam to span across to the south column, creating Segment I when the area was covered. The construction of the south side of the west wall across from this corner indicates the same type of modification, in which an east-west ceiling beam was modified to accommodate a north-south beam to span across to the south beam of the east pair of columns (Figure 3.381). This supports a hypothesis that originally the south portion of these segments were roofed and the area to the north stood open, forming an open gallery patio.

Segment N

The ceiling in the north end of Segment N is a course higher than the other segments; its height is created by the beam and corbel layer over the west columns, while other segments have only a corbel layer. The construction of the southeast corner of Segment N is not clear; no seam appears to be present, but it contains a very unusual multiple corbel construction as well as an unusual connection to Upper Portada (Figures 3.382 - 3.384), suggesting the area may have been modified or adapted to later constructions (Figure 3.385).

Other areas

Many areas in the center of the gallery are presently collapsed, but appear to have formed a set of segments, here called Segments L, J, and K, between Segments M and I (Figure 3.386). Presently the west end of F, the south end of H, and all of I and J are collapsed. The doorway to Segment L from Segment M is collapsed but its frame is clearly visible (Figure 3.387, 3.388). Segment K is also collapsed, and appears to be wider than Segments F or G; through the rubble can be seen an intact beam running east-west that is at least 1.5 meters long, and none of the wall surfaces can be directly observed through the rubble, suggesting the beam is even longer. What appears to be the north-east edge of the door to section L can be seen, as can two stones in the top course at the south west corner of section K. This suggests that Segment K was a room connected to Segment M via Segment L and connected to Segment H via Segment J.

The door to Seg G was closed off after its original construction (Figure 3.362). When or why this occurred is unclear.

Summary

Taken together, these data suggest that Columnas-Vigas was constructed in two major episodes. In the first episode, called the South Columnas-Vigas episode, an open patio was framed by an exterior wall to the north, a wall to the west, and gallery segments to the south; this gallery patio, called the Columnas Patio, stood open to the east. The plaster in the seam in suggests that at least part of the inside of the gallery patio was plastered in red. The columns were built, either separately from or as part of the next episode, called the North Columnas-Vigas episode, in which the plaza was covered and segment walls were abutted to the former exterior north wall. The plaster seam in Segment E and the entrance to Segment I from Segment N marked the transition and modification area for this addition, the columns were filled in for increased support, and the gallery was extended to the east.

When the columns were added to the patio is unclear. The filled areas between the columns suggest the columns may have stood free originally and later were covered. However, the overall form and construction of the columns suggest the columns were constructed as structural elements, to support the ceiling, in which case they likely were added with the construction second episode. One possibility is that these columns may have replaced earlier, non-structural columns that may have stood in the plaza. Nevertheless, the use of columns as structural supports, whether or not they were originally intended to be used as such, is unusual at Chavín. It is difficult to ascertain whether the collapse of surrounding segments indicates that the experiment failed, or whether the collapse was a result of the large-scale historic-period trenches directly above and to the east of this gallery.

A number of larger construction principles are evident in Columnas-Vigas. For example, the gallery was entered through descending stairs into Segment N. Additionally, the gallery underwent much modification, in order to accommodate the addition of segments to the north and to roof the earlier gallery patio; with these modifications, the former north external wall became the internal north wall of gallery to which new constructions were abutted.

The Portada Gallery

The Portada Gallery is located in the center of Building A (Figures 3.389 - 3.391). It is a staircase covered by a stepped ceiling, bending approximately ninety degrees at two landings. A possible horizontal seam suggests it was built in two primary episodes (Figures 3.392, 3.393). The stonework near the top entrance of the gallery suggests modifications or a possible third episode could have been added later. Portada presently connects the top of Building A with Doble Ménsula. A major seam exists between Doble Ménsula and the lower doorway to Portada. The lower doorway is built of fine, battered stonework in an ABB coursing pattern. It has long been believed to be a former exterior doorway that aligns with the south seams on the east and west

exterior faces (Tello 1960:97; Lumbreras and Amat 1965-1966:157, Plano II). These relationships are examined further in later chapters.

Construction

Level 1 analysis suggests that the Portada Gallery was built in two episodes. The stairway contains an important coursing transition that is subtle but clear, and suggests a seam (Por-A-1-Hz) exists here. This transition is marked by observing the alignment of corresponding courses on walls opposite each other in the stairwall. Below the transition, in the lower portion of Portada, courses on walls opposite each other do not align, meaning they sit at different levels, whereas above the transition they do align. For example, at the bottom of Portada, inside the doorway, the courses on the west and east walls only align with each other underneath the doorway lintel (Figures 3.394, 3.395); above the lintel and up to the tenth course above the second landing, corresponding courses on opposite walls across the stairwell do not align with each other (Figures 3.396 - 3.399). Only above the tenth course do they align (Figures 3.400 - 3.410). The tenth course is built with stones of very different sizes, with the larger course on the west, as if height had to be equalized there. The beam above the second landing rests on the tenth course, and its size is very different, as if it too was used to equalize levels. The level of the tenth course continues across to the third landing. Additionally, the walls of Portada are battered slightly differently above the tenth course than below. All this evidence suggests a subtle horizontal seam exists above the tenth course, a seam that suggests that the Portada stairs initially climbed only to this level, and that the portion of the gallery above this level was added in a later episode. These two construction episodes are referred to as Lower Portada and Upper Portada. This hypothesis has significant implications for understanding the construction sequence of this area, and is examined further in the Levels 2-3 analysis.

Possible vertical seams

Two corners contain vertical abutment seams, but analysis of their locations in the model and the surrounding constructions shows that one may mark a significant chronological separation, while the other likely does not, but rather shows techniques of construction.

The first seam lies in the northwest corner at the top of the gallery. The north wall abuts the west wall, and the two walls contain different stonework and different coursing (Figures 3.411 - 3.413). The corbels, however, squarely rest on the west wall and the beams run north-south, sitting on the north wall and the beam over the top of the steps. A possible explanation is that the west wall originally stood open at the top of this landing, along with the beam over the stairs and the east wall on which it rested, before the north wall, corbels, and beams were added. Although not conclusive, this evidence suggests that perhaps an open space stood here between the entrances to Portada and Columnas, a space that was later filled in with a common central entrance staircase ascending to the north.

The second seam is located in the northwest corner of the bottom landing, just before the stairs descend into Doble Ménsula. The stonework here indicates that this seam likely was a by-product of the construction technique used. The north wall does abut the west wall (Figure 3.414 - 3.416), but with a possible overlap of the north wall into the west wall in the fourth course from the top. The ceiling beams sit squarely over both walls. Although the walls contain different stone sizes and coursing, the coursework actually lines up quite well, given simply that on the west wall two large courses each make up two small courses on the north wall; the bottom course of the west wall even changes to two courses just before the corner. The west wall's coursing follows an ABB (large-small-small) pattern typical of exterior walls, while the north wall's follows the BBB (small-small-small) pattern characteristic of interior walls. The west wall is continuous with the west side of the south-facing entrance from Doble Ménsula (Figure 3.417), which, as noted above, was formerly an exterior doorway. This seam, therefore, marks a transition between an exterior wall coursing pattern to one more characteristic of internal spaces, while maintaining

consistency in stonework quality between the two walls. Taken together, the overall course alignment, the similar stonework, and the ceiling structure suggest that this abutment was part of a single construction episode. It is particularly noteworthy because it shows a transition from exterior to interior stonework patterns.

Connection between Portada and Columnas

The entrance area between the top of the Portada Gallery and Segment N in the Columnas-Vigas Gallery is unusual and appears as if it may have undergone modifications. The seam at the upper northwest corner of Portada, as described above, along with the unusual multiple-layered corbels in the south end of Segment N in Columnas-Vigas, suggests that this area may have been modified or added in a construction episode after Upper Portada and South Columnas-Vigas were built.

Intertwined Snakes Carving

Embedded in the west wall of Upper Portada is a 60cm-wide by 21cm-tall stone block carved with two intertwined snakes, documented during mapping in the 1998 season (Figures 3.418-A, 3.419 - 3.423). The face of the stone is quite eroded, but the carved figures clearly comprise two intertwined snakes facing opposite directions, each with a protruding tongue. This carved image is one of four examples of art found in situ in the galleries, the others being the Lanzón monolith in the Lanzón Gallery and the two carved ceiling beams in the Vigas Ornamentales Gallery. It may be the carving documented by Bennett (1942:Figure 28), which is listed without provenience.

The erosion of the snakes suggest that the stone may have been reused from an earlier structure, and the manner in which the snake bodies are not entirely contained within the block face, but rather continue off its edges, suggests that perhaps these snakes were part of a larger image. If such an image, or a fragment thereof, can be identified, it may provide insights into the

history of the intertwined snake carving, possible reasons for its placement in this gallery, the construction of this gallery, and the use and possible reuse of art within architectural contexts. The possibility it may have been reused should be considered when studying how this double-snake image fits into the known corpus of Chavín art styles and their sequence; it may have been carved prior to the construction of Upper Portada, in which it sits. Additionally, it is interesting to consider whether or not plaster would have covered the gallery's fine stonework and this carved block in the Portada Gallery.

Summary

Evidence of a horizontal seam in Portada suggests the gallery likely was built in two primary episodes, Lower and Upper Portada, with possible modifications or the addition of a third episode at the top of its stairs. The ceiling over the stairs is stepped, with no corbels. A block containing a carving of two intertwined snake, documented without provenience in Bennett (1942:Figure 28), is embedded in the west wall of Upper Portada. The form and preservation of the carving suggests that the block may have been reused from an earlier construction.

The Doble Ménsula Gallery

The Doble Ménsula Gallery is located in the south-central area of Building A (Figures 3.424 - 3.426). Construction evidence suggests that Doble Ménsula Gallery was built in two episodes: Lower Doble Ménsula – extending from the north entrance to the base of the stairs to the south – followed by Upper Doble Ménsula, extending up from the base of the stairs to the south (Figures 3.427, 3.428). Lower Doble Ménsula underwent significant deconstruction and modification to accommodate the addition of Upper Doble Ménsula.

Lower Doble Ménsula was named after the double courses of corbels or "Ménsulas" that support its ceiling (Figures 3.429, 3.430). It appears to have been built in one episode, as no

seams are evident within the gallery. It does clearly abut the lower entrance of the Portada Gallery (Figures 3.431 - 3.435), at the seam DM-A-1. The stonework in Lower Doble Ménsula is mostly large, with some medium stones, with regular coursing and chinking, and massive ceiling beams.

Upper Doble Ménsula also appears to have been built in one episode, as no seams are evident within in. The stonework in Upper Doble Ménsula differs from that in Lower Doble Ménsula. In the main hallway, the stonework is slightly smaller than that in Lower Doble Ménsula, with less chinking but even coursing (Figure 3.436). The side segments, however, have very small, chunky stonework with loose coursing and little chinking (Figure 3.437). The third segment is largely collapsed, but through the rubble the westernmost segment can be reached. This segment has been reconstructed in modern times and contains very different stonework and mortar (Figure 3.438). Its west wall extends slightly less to the west than the segments in Lower Doble Ménsula.

Seam between Lower Doble Ménsula and Upper Doble Ménsula

Of primary importance in this gallery is the transition area between Lower Doble Ménsula and Upper Doble Ménsula, near the staircase at the south end of Segment A in Lower Doble Ménsula (Figure 3.439). A seam, referred to as DM-A-2, exists here, suggesting that Lower Doble Ménsula and Upper Doble Ménsula were built in different episodes.

The seam is located at the east-west plane where the gallery narrows at the base of the stairwell, in the corners where the wide and narrow segments meet. In the west corner, the portion of the west wall located underneath the corbels and north of the stairwell runs behind the stairwell wall, indicating an abutment of the stairwell to the west wall (Figures 3.440, 3.441); in contrast, the stairwell stones at and above the level of the corbels in the wall to the north sit above the plane of the west wall. On the east side, the top of the intersection is less clear than on the west, but indicates some of the stones are integrated from the east wall into the stairwell wall. Below

this, the stones continue to appear integrated, with the east wall running behind on top and the stairwell wall stones running behind near the bottom. (Figures 3.442, 3.443). Additionally, in Upper Doble Ménsula, the beams of the stepped ceiling above the steps abut the ceiling structures to the north (Figures 3.444, 3.445), with no overlap between them. This suggests that Upper Doble Ménsula was built up against the upper extent of Lower Doble Ménsula. Taken together, the stonework where the stairwell wall meets the lower walls and the abutment of Upper Doble Ménsula against the Lower Doble Ménsula beam structure indicate that Lower Doble Ménsula was built before Upper Doble Ménsula. This is consistent with the stonework differences between the two levels.

The construction of this seam suggests that Segment A in Lower Doble Ménsula had a south wall originally, and that this wall and the ceiling above it were deconstructed to accommodate Upper Doble Ménsula. In eight out of the nine segments with end walls in Lower Doble Ménsula, the ceiling beams at the endwalls are lowered and supported with corbels (Figures 3.446, 3.447). The one segment that does not have a lowered beam has level beams that do not step up as do those in the south of Segment A. To build Upper Doble Ménsula, it would have been necessary to remove the ceiling beams and corbels, as the beam would have been too low to accommodate the stairs. Even if the south end of Segment A did not have a lowered beam, its ceiling still would have needed to be raised. The vent in the stairs likely is the continuation of a vent in the original south wall.

The walls just north of the seam appear as if they were modified as well to accommodate this addition. In the east wall, a narrow “column” of stone lies underneath a large beam and its corbel, smaller than the others to the north, on the level of the others in this segment; to the south of this, another “column” of stone appears underneath a smaller corbel and beam a course higher than their counterparts a stone to the north (Figures 3.448, 3.449). These columns form two seam-like breaks in the wall, but these breaks terminate a few courses above the floor. Taken as a whole, it appears as if an original large, lowered end wall corbel could have been removed so that

the wall could be extended higher and integrated with the narrowing corner also being built, and that then all this was covered with a raised corbel and beam. The wall below this may have been slightly reconstructed for some unknown reason, creating the “columns”.

The wall to the west of the base of the stairs is less complicated and looks like it may be mostly original and has undergone less alteration. The south end appears as if it could have had a large lower corbel that was lifted and replaced with the shallow corbel in place now, the wall course to the south of this corbel, and the corbel and beam raised above this. A lowered end wall corbel typical of this gallery would have sat a course lower, meaning the second course from the south end could have been a corbel, extending underneath the extent of the present shallow corbel (Figure 3.450). The narrowed stairwell wall could then have been built, overlapping the west wall, which supports the raised beam against which the upper stairwell abuts.

The integrated stones of the east wall with the east stairwell wall support the conclusion that the east wall was likely redone to accommodate the raising of the end wall beams; this reconstruction enabled the east wall to be more integrated with the added stairwell wall edge than the west wall was. The west wall stonework running behind the west stairwell wall also supports this, and, along with the beam abutment over the stairwell, suggests that the walls and beams were raised before the stairwell was built.

The above evidence supports the conclusions that Upper Doble Ménsula was built later than Doble Ménsula, and that Doble Ménsula was very skillfully adjusted to accommodate the addition in this transition area.

Summary

The Doble Ménsula gallery was built in two episodes. The seam between Lower Doble Ménsula and the Portada marks where Lower Doble Ménsula was abutted to the battered former exterior doorway of Portada, changing it to a completely interior gallery. A seam at the staircase to Upper Doble Ménsula marks its addition to Lower Doble Ménsula, which required significant

modifications to the south end of Segment A of Lower Doble Ménsula. The stairs to Upper Doble Ménsula are stepped and contain no corbels, but ascend rather than descend into the gallery. They connect two different chronological episodes, containing different stonework.

The Caño Gallery

The Caño Gallery, or the Gallery of the Waterspout, is located in the southeast corner of Building A and opens to the south face (Figures 3.451 - 3.454). This gallery is not noted in earlier publications. It is referred to here after the unusual waterspout-like stone on the south face opening (Figures 3.455, 3.456).

No seams or stonework changes are present in the gallery, indicating it was built in one episode (Figures 3.457). Its form clearly indicates that it was built to drain water. In the highest reaches of the gallery, a vertical shaft approximately 40 x 40 cm in cross section descends approximately 0.68 m to a small canal with a stepped slab floor, measuring approximately 50cm wide x 60 cm high (Figure 3.458). This canal curves and descends approximately 2.6 m from the north east (Figure 3.459), and opens from the east into the top of the gallery's vertical shaft approximately 0.68 m below the top of the shaft. Finely constructed, the shaft descends 4.48 m, measures approximately 60 cm x 60 cm in cross-section, and is built of small-medium stones with slight chinking. The top of the shaft is covered by small beams (Figure 3.460). It opens onto a floor of overlapping stepped slabs that descend south out the gallery, ending in a carved stone resembling a waterspout. The ceiling is stepped and the height of the channel tapers as it descends (Figures 3.461, 3.462). The gallery clearly forms a functional unit, supporting the conclusion that it was built in one episode.

The small dimensions of the entrance suggest that the Caño Gallery was not meant to be entered once its construction was complete. No plaster is evident.

The Caracolas Gallery

This gallery is located in the southeast side of the Circular Plaza Terrace, just northeast of the entrance to Escalinata (Figures 3.463 - 3.465). It is currently entered through a gap in its ceiling; the location of the original entrance and the full extent of the gallery are unknown. It was documented in Lumbreras (1977).

The single accessible segment of this gallery contains no clear seams and appears to have been built in one episode (Figure 3.466). Most of what is visible in the gallery appears original; the west wall stonework is similar to that in the north and south walls, and the remaining ceiling beam overlaps all three (Figure 3.467). Three niches occupy the south wall. One vent trends through the west wall, while from the north wall another vent partially filled with much dirt trends north at least 2.02 m, as measured three-dimensionally.

The east end of the gallery, however, has been modified and blocked (Figure 3.468). The eastern wall is a filled-in doorway with strange stonework in its corners: the south corner looks like an abutment, while the north corner is unclear but appears bonded. The gallery likely continued to the east, but the way the ceiling intersects with the wall and the way the wall narrows suggests this doorway could have opened to an ascending staircase. The full extent and form of this gallery thus are unknown.

On the whole, this segment appears built in one episode. When this east doorway was filled in and what lies to the east of it are unknown.

The Ofrendas Gallery

The Ofrendas Gallery (Lumbreras and Amat 1965-1966; Lumbreras 1993) is located in the north side of the Circular Plaza Atrium, within the Circular Plaza Terrace (Figures 3.469 - 3.471). Stairs descend into the gallery from the top of the Circular Plaza Terrace. The gallery contains no seams and has consistent stonework throughout, suggesting it was built in one

episode (Figure 3.472). The gallery contains vents in the north walls of alternating north-south segments 2, 4, 6, 8, and 9; these vents trend north towards Building C. A vent also leads east out of the east end of the gallery.

The Campamento Gallery

The Campamento Gallery is located in the northeast side of the Circular Plaza Terrace (Figures 3.473 - 3.475). No seams exist in the visible segments, suggesting they were built in one episode (Figure 3.476). This gallery is in poor shape and contains modern supports. The original extent of the gallery is unknown, as is the location of its original entrance. Currently the gallery is entered via a hole between ceiling beams. Two segments are blocked by collapse and fill – the north extent of Segment C (Figure 3.477), and the east extent of Segment A (Figure 3.478) – but the walls and the ceiling beams above the fill clearly indicate the gallery continued beyond the present fill.

The Cortada Gallery

This gallery is located in the east end of the Building E (Figures 3.479 - 3.481), and the remains of it appear to have been built in two episodes (Figure 3.482). The east part of both Building E and the gallery have been washed away by incursions by the river in the early part of this century (Tello 1960). (Figures 3.483, 3.484). This gallery was noted by Tello and named Gallery XV (Tello 1960:113), but it is referred to here as the Cortada Gallery, or the Cut Gallery, after its erosion by the river cut. The gallery is in poor condition: the west end is collapsed and the remainder of the gallery is unstable, with leaning and bowing walls and cracked beams (Figures 3.485, 3.486). It is unclear how far the gallery originally extended into the mound.

The construction of the gallery is very simple, with no corbels, vents, intersections, or turns. The walls are constructed with mostly large unworked stones, loosely and irregularly coursed, with irregular chinking.

One seam (Cor-A-1) exists in the gallery, near of the present entrance. Analysis of the stonework indicates that the east side of the seam was abutted against the west side of the seam. The stonework on the west side is larger, more regular, and forms a straight edge, while on the east side it is smaller, more chunky, and more irregularly placed up against the edge of the west side (Figures 3.487 - 3.492). The courses do not align across the seam. The beam just to the east of the seam steps up one course on the south wall but not the north (Figures 3.493 - 3.495). The form of the seam thus indicates that the west side of the seam was constructed first, and then the east side was abutted to it. This suggests that the gallery may originally have been entered from the east at this seam's edge.

The Escondida Gallery

This gallery is located on the west side of Building E (Figures 3.496 - 3.498). This small section of the gallery appears to have been built in one episode, as no construction seams can be seen (Figure 3.499). It is presently entered through a gap created by a rotated block in the side of the building, into the end of a segment (Figure 3.500). Only a very small portion has been cleared, and it is in poor condition. Tello (1960:113) named it Gallery XV (Tello 1960:113), but it is referred to here as La Galería Escondida, or the Hidden Gallery, after its obscured location.

An end wall seam may exist, with small, irregularly coursed stones of the sidewalls abutting the west end wall, which is atypically comprised of the same large, well-coursed stones that make up the external wall (Figures 3.501 - 3.503). The side walls are in poor condition, containing much fill and cave-in (Figures 3.504 - 3.506). The external wall does not appear to have blocked an original entrance, although the external wall itself is partially buried and not

completely clear. This suggests this is not likely the original entrance, and that the location of the original entrance within the mound is not known.

The Tello High Gallery

This gallery is located at the present top of Building D, also known as the Tello Mound (Figures 3.507 - 3.511); its location inspired the name used here, no published names for it were found. Currently only the west end of one segment remains (Figures 3.512, 3.513). Its atypical and possibly reconstructed interior stonework (Figures 3.514 - 3.516) contains small-medium stones, chinking, little mortar between the stones, and an unusual slanted niche on the north wall. No seams are evident in what remains.

The Tello Low Gallery

This gallery is located lower in Building D, the Tello Mound (Figures 3.517 - 3.519, 3.510 above), and is referred to by its place within the mound. Although it contains two seams, one at the entrance and the other an end wall seam on both sides of the end of the gallery, the construction history of the gallery is unclear. It bends and is extremely small, perhaps serving as some sort of large, twisting vent. Inside, the stonework is crude and the ceiling beams are tiny, with some small corbels. Vents connect to the exterior.

Conclusions regarding gallery construction episodes and construction principles

Gallery Seams and Episodes

Thirty-five of the documented internal seams mark significant construction episodes in the galleries, while ten others either have unclear chronological implications or appear to be a result of construction techniques used within a single building episode (Figure 3.520). The above

analysis of these seams, their surrounding stonework, and the galleries identifies thirty-nine gallery construction episodes, and sequences the episodes of individual galleries. Thirty-four of these gallery episodes exist in Buildings A, B, C, and the Circular Plaza Atrium; thirty-one of them are shown in Figure 3.521. In this figure, the episodes are color-coded according to their relative sequence within each gallery, as presented in the above analysis and figures, rather than according to a site-wide sequence.

Construction Principles

A number of construction principles are illuminated in this analysis of the construction episodes of the galleries:

- Many galleries were built in multiple episodes.

- Significant modifications were common and occurred in most of the galleries, largely to accommodate the addition of new episodes.

- Some external walls were converted to internal walls by the abutment of a gallery against them.

- Batter marks tall interior walls as well as tall exterior walls.

- Plaster can be found in seams.

- Staircases do not contain corbels.

- Ceilings over staircases and stepped canals are stepped.

- Galleries or levels within a gallery connected by stairs were built in different episodes.

As a corollary to this, the location of a stairwell (without corbels) adjacent to a hallway with corbels suggests that they were built in different episodes. In galleries in which a staircase was built in the same episode as an adjacent segment, the staircase and the segment are the same width. In galleries in which the staircase was built in a different episode than an adjacent segment, the adjacent segment is wider than the staircase. In these cases, corbels in the wider

segment create the extra width. This relationship does not determine the chronological order in which the segments were built, but it does suggest that they were built in different episodes.

-Galleries were entered from the outside through descending stairs.

Most gallery episode entrances fit this pattern, as do hanging staircases. Exceptions are explained by other factors. First, most current entrances that go straight into the galleries are not original; for example, the current entrance to Zanja and the current east entrance to Columnas-Vigas were both created by historic-period trenches in the east face. Second, the original entrances of other galleries are buried. Third, a set of galleries -- South Columnas-Vigas, Middle Lanzón and Upper Laberintos, and North Loco and Mirador -- appear to have been entered directly from gallery patios. Fourth, others galleries apparently were drainage canals that were not meant to be entered after they were constructed. Finally, as the exception to the rule, Upper Doble Ménsula was entered not from the exterior, but rather via stairs ascending from Lower Doble Ménsula.

The chronology of construction episodes within individual galleries, along with the construction principles identified in this chapter, form the foundation for analyzing how the galleries spatially relate to each other and to the exterior. These relationships indicate larger construction phases in which the gallery episodes were built, as seen in the chapter that follows.

CHAPTER 4

LEVELS 2-3 ANALYSIS: SPATIAL RELATIONSHIPS BETWEEN INTERNAL AND EXTERNAL ARCHITECTURE

The individual galleries and gallery construction episodes at Chavín were not isolated units. They were part of the larger buildings in which they were constructed, and were usually located in close proximity to other galleries and the internal ventilation system. In studying how the gallery episodes examined in the previous chapter spatially relate to each other and to the external architecture, many meaningful relationships emerge that enable larger construction phases to be identified. Analyses follow a systematic process of examining, in plan and profile, how galleries and exterior features relate to each other in three-dimensions. In the below discussions, some issues relevant to these analyses are addressed first, and then the analyses are presented by area, starting with Building A and proceeding to Building B, Building C, the Circular Plaza Atrium, Building D, and Building E.

Issues in Studying Spatial Relationships at Chavín

Horizontal seams

A horizontal seam is a plane that separates two chronologically distinct vertical constructions, as in the case in which a phase is built directly on top of another. Horizontal seams require close consideration when investigating Chavín's architectural construction sequence, because they can easily become indistinguishable from coursing layers above and below them -- both in the galleries and on the exterior building faces. For example, one such seam exists between the low platform at the south end of Building A and the construction above it, as

discussed in Chapter 1 and Rick et al. (1998). In this case, the seam is not visible in the coursework (Figure 4.1). The size and rough finish of the stonework is similar on either side of the seam, and while the coursing pattern switches from AB to ABB in this area, the course at the top of the platform is a B and the course above it is an A, so without other data it is not clear whether the pattern shifts at the top of the platform, possibly indicating a horizontal seam. Only the south vertical seam, which terminates at the platform, indicates that the platform is chronologically separate from the rest of the SA. This example indicates that horizontal seams will not always be identifiable in the coursework; they can be concealed within the coursing by continuing the same building style on top. Similarly, a transition between two different stonetypes does not in itself indicate a horizontal seam.

A horizontal seam can be identified by a vertical seam that intersects it or by galleries align internally with it. Seams are planar, and therefore the alignment of groups of planar surfaces (such as walls, ceilings, or floors) suggests the presence of a seam along that plane. If a gallery crosses that seam, its construction must somehow account for this, either with evidence of an addition at that level or through evidence of deconstruction and modification. These criteria may mean that some horizontal seams may not be identified: if a horizontal seam is not evident in the coursework, and no vertical seam intersects it and no internal galleries align with it, it likely will not be detected.

The Ventilation System

The ventilation system in the buildings at Chavín, particularly in Buildings A and B, are an important source of data regarding the site's construction sequence, construction techniques, and function. The galleries contain many ventilation shafts that connect segments of a gallery to others in the same gallery, to other galleries, and to the exterior. With the mapping system we were able to learn their length and trajectory by collecting three-dimensional points down them.

This demonstrated that some are still fully open, while many others are blocked by collapse or fill. Additionally, the vents do not always exit perpendicularly out of the galleries, as earlier maps have represented them (Lumbreras and Amat 1965-66; Lumbreras 1971; Kaufmann-Doig and Gonzales 1993). Some vents curve, some trend from the gallery at an angle. Some change shape and size, frequently through lintels that drop, shortening the height of the vent after it has left the gallery.

Because vents trend through long expanses of building, they provide information about the construction sequence. Based on the conclusion that they were indeed meant to connect with another segment, another vent, another gallery, or the exterior, rather than terminating without connecting with another space, vents can provide information about the order in which areas of the temple were built. For example, some vents were continued through later phases and open to the exterior, while others were blocked by later additions. When a vent terminates without reaching the exterior, it is likely blocked by collapse, fill, or a later structure. When a set of vents terminate at points along a plane, the alignment of their farthest points along that plane suggest that as a group they may have been blocked by the addition of a new phase at this plane, and thus that a seam may exist at that plane. In some cases they inform us about construction techniques, such as how gallery placement was determined, and how vents were aligned with other elements during construction.

The drainage system within Building A

A set of galleries appear to be part of a complex vertical drainage system within Building A. Because these galleries cover large interior vertical expanses that “cross” multiple exterior horizontal features, such as changes in stonework and coursing, they provide valuable clues about the construction sequence. The three known galleries that comprise this system are the Caño Gallery, documented during the 1998 field season, Gallery XIII (Tello 1960) and Pasos Perdidos

(Roosevelt 1935; Tello 1960; Lumbreras et al, 1976). Similarities in form between these three galleries suggests their construction followed a standard set of rules that were consistent across construction phases. Differences between these galleries reflect their individual variation around these rules, responding in part perhaps to local construction and functional needs. The architecture of these spaces suggests that their main function was to drain Building A internally through a system of vertical shafts that empty over downward-sloping, stone-lined canals. Each exits Building A in a different direction: north (Pasos Perdidos), west (Gallery VIII), or south (Caño). This drainage system may have been constructed internally rather than externally both to channel heavy rainy-season runoff to keep it from degrading the buildings, and as part of a ritual hydraulic-acoustic function of the galleries, as hypothesized by Lumbreras et al. (1976).

It is unclear whether or not the vertical shafts of these drains connected directly with the top of Building A. The vertical shaft in the Caño Gallery is the only one that is still fully intact, and it does not connect with the top of Building A. Instead, the top of its vertical shaft is covered by small lintels, and another canal enters the gallery near the top of the vertical shaft, curving and connecting to a smaller vertical shaft (see Level 1 analysis). Caño may connect to the set of canals found in the top of the SE corner of Building A by Bennett (1944). The vertical shafts of Gallery XIII and Pasos Perdidos become plugged with rubble as they approach the present surface of Building A, but the original surface Building A no longer exists here and they likely climbed higher. It is possible that they could have been like the Caño Gallery and connected via small canals to the top of Building A or other galleries or canals.

Dealing with architectural complexity at Chavín: methodological issues

A fundamental issue quickly emerged in analyzing the spatial relationships of the architecture at Chavín: how to approach the richness of the architecture in order to begin to study its chronological history. Viewed as a whole (Figure 4.2-A), the complexity of the architecture

begins to become apparent. To address this complexity, rather than approaching the site as a whole, I began by dividing the architecture by areas, using known external seams as well as building distinctions as guidelines to define the areas, but not associating these areas or their names with chronological meaning. Beginning with the NEA area, the northeast corner of Building A, defined by the seams A-E-1 and A-N-1 in Rick et al. (1988), I divided the remainder of Building A into three broad areas: the NWA area (the northwest corner of Building A), the MA (the middle portion of Building A) and the SA (the south portion of Building A). Building B, Building C, and the Circular Plaza Atrium also were delimited as distinct analytic areas. The main purpose in approaching the three-dimensional study of the architecture by area this way was to be able to systematically analyze and reference specific relationships within and between architectural elements, without implying chronological relationships in doing so. Isolated construction phases resulting from the spatial analyses were then named after the areas that comprise them. Following this approach, the below discussions are presented by area, beginning with the NEA.

Spatial Relationships within Building A – Northeast corner of Building A (NEA)

Delineation of area

In the following discussions of the NEA (Figures 4.3, 4.4), please refer to Figures 4.5-A, 4.6-A, 4.7 - 4.9 as visual guides to the text.

The NEA is defined by the A-E-1 seam at its south extent (Figures 3.49, 4.10), and seam A-N-1 on the north face of Building A at its west extent (Figure 4.11). Four galleries have been identified in the NEA: Escalinata, Alacenas, Zanja, and the East Face Gallery, along with the East Face Vent. Spatial data were collected for features on the external architecture so that they could be analyzed in relation to the galleries to determine the construction history of this area of the temple. On the east face of the NEA, these features include: seam A-E-1, which marks the south

extent of the NEA; the transition between the coarse and fine stonework, referred to as the course-to-fine transition (CFT); the north edge of the stairway between the East Face Gallery and the Black and White Portal; the top A course just north of the Black and White Portal; the bottom of the A course at the floor of the East Face Gallery; the East Face vent; and the perimeter of the remaining façade. On the north face, the mapped features include the top of the high full A course; the bottom of the A course equivalent to the base of the East Face Gallery; the entrance to Escalinata; and the vent just above A-N-1.

NEA Gallery-to-Gallery relationships

The relationships between the galleries of the NEA suggest that they were built at the same time, with a later modification to Alacenas. This is the conclusion of analyses of the spatial relationships between many internal features, as presented here in a summary of significant relationships.

The galleries' elevations overlap, with no alignments along a horizontal plane, as described in the following relationships. The ceiling of the Zanja gallery sits only slightly lower than the top of Escalinata. The present east entrance to Alacenas and the base of the south entrance opening to Alacenas, both modified by Marino, also sit at this level. The floor of Zanja is covered with substantial fill; the level of this fill presently lies near the level of the ceiling of Alacenas. If the original height of Zanja is estimated to have been similar to that of Alacenas, the elevation of its floor would overlap the center of Alacenas. The East Face Gallery spans most of Alacenas, and, given that its Level 1 analysis indicates it likely extended to the top of the NEA, it likely would have overlapped Zanja as well. Escalinata spans all of these galleries, extending from the base of the NEA to the top. These overlaps, and the fact that no subset of the galleries aligns on a distinct horizontal plane separate from the others, suggests the galleries in the NEA were built at the same time.

Another line of evidence linking the construction of Escalinata with Alacenas is the fact that the vent in the east segment of Alacenas opens into the south wall of Escalinata, centered between the two staircases, above the central landing, and in the relieving window. The placement of this vent suggests that these two galleries were planned as a functional unit, and constructed as such in one construction phase. It also provides an explanation for why Alacenas sits lower than Zanja, rather than closer to the surface; the placement of the gallery seems to have been dictated by the need to locate this vent directly in the center of Escalinata's south wall.

NEA Galleries-to-Exterior Relationships

The two staircases in the NEA are each effectively centered in their respective faces. On the east face, the distance from the south edge of the East Face Gallery entrance to the A-E-1 seam to the south measures 16.86m; from the north edge of the gallery wall (not the support column) to the north corner of Building A measures 17.05m. The Escalinata gallery entrance is centered in the north face defined by the NEA corner and A-N-1; the distance from the east edge of the doorway to the east corner of the NEA measures 18.48m, while the distance from the west edge of the doorway to the estimated west corner (estimating the slope of the buried A-N-1 seam to this level) measures between 18.23 and 18.63m.

The present upper limit of A-N-1 intersects, in profile view, the elevations of Escalinata, Alacenas, and Zanja, and likely would intersect East Face Gallery if the East Face Gallery ascended to its full height. No seams are present at this level in these galleries. This suggests that originally either A-N-1 extended higher to the top of the NEA, or the NEA stepped down west of Escalinata to the level of A-N-1. Unfortunately the exterior stonework at this level on the north face is missing.

The entrances of the two staircases in the NEA align with respect to each other. The base of the East Face Gallery entrance sits at the level of the top of the Escalinata entrance lintel, and the top of its entrance corresponds with the bottom of the relieving window.

The relationship of the East Face Vent to other galleries is unclear. It does seem clear that it connected with something at the same level as the vent, as its ceiling and floors are not stepped and thus suggest it was a straight vent and not a drainage canal. No known galleries sit at this level and in line with the vent, suggesting that other galleries may exist in the NEA.

Much of the top of the NEA exterior walls are missing; much of Alacenas and Escalinata and all of Zanja lie above the current wall perimeter. Although only a single segment of Zanja is visible, this gallery likely was entered from above, given the pattern in Level 1 analysis that most galleries were entered from above.

NEA Stonework and the Coarse-to-Fine Transition

Differences in stonework between the north and east faces carry significant implications for understanding the construction of the NEA and the rest of the temple. The lower portion of the east face is comprised of coarse, largely quartzite stonework laid in an AB coursing pattern with substantial chinking (Figures 4.12 - 4.21). Above this sits finely worked, primarily granite stonework, laid in an ABB coursing pattern with sparse chinking. The line at which these meet is called the coarse-to-fine transition, or CFT. The entrance to the East Face Gallery sits in the coarse stonework, while an edge marking the north boundary of the East Face North Staircase sits in the fine stonework, south of the East Face Gallery entrance. Although the south edge of this staircase is currently missing, and the steps are missing or buried, the staircase was excavated and identified by Tello (1960:132) (Figures 4.12 above, 4.22, 3.50).

The north face of the NEA (Figures 4.23 - 4.26) is built of large, coarse blocks in an AB coursing pattern. Gaps between the large stones suggest that much chinking, though now sparse, used to exist here. Much of the north face is buried or missing; on the east end the base of the

wall is buried and the top is missing, while west of the Escalinata entrance the whole wall is buried or missing, except for a small area near the vent above seam A-N-1. No CFT exists on the north face, and small portions of four courses of coarse stonework remain on the north face above the level of the CFT on the east face.

The coarse courses of the east face continue uninterrupted across to the north face; unfortunately, at the level of the fine coursework the northeast corner is missing, so the transition between fine and coarse stonework at the corner cannot be observed (Figure 4.27).

Three primary scenarios could account for this stonework arrangement on the north and east faces of the NEA. First, the low, coarse layers could have been built, then a second phase added on top of them. In this case, the CFT would mark a horizontal seam, and the lack of a visible horizontal seam at the same level in the coarse stonework of the north face would be similar to the lack of a visible seam between the SA Platform and the phase above it, discussed above. This scenario is contradicted by the lack of seams in the galleries that cross the CFT, namely East Face Gallery and Escalinata, but it warrants a closer examination of these two galleries at the specific level of the CFT.

Along with Alacenas and Zanja, most of the East Face Gallery lies above the CFT, which sits at the top of the course containing the doorway lintel to the East Face Gallery. The interior stonework of the gallery remains coarse even as the gallery climbs into externally fine coursing. The CFT sits at the level of the rubble ceiling fill west of the entrance lintel. No corresponding seam can be seen at this level inside the staircase, although at that level rubble fill partially obscures the walls. Any horizontal seam at this level, however, would functionally make the gallery essentially useless. It would indicate that the staircase initially ascended a mere 2 meters up to the level of one course above the entrance, ending on no discernable landing. Neither the ceiling structure nor any other visible features indicate a landing or platform existed at this level. These data suggest that the gallery did not originally end at this elevation, and that the coarse-to-fine transition does not mark a horizontal construction seam in the East Face Gallery. The CFT

therefore does not overrule the Level 1 data indicating there is no seam in this gallery and that it was built in one episode.

The level of the CFT intersects Escalinata approximately 0.3 m above the base of the relieving window, aligning with no other features. The stonework at this elevation does not show signs of a seam, given the construction of the support lintels and the walls, which indicate this gallery was built in one episode. Such a seam would break up this gallery that was clearly designed as a functional unit. As with the East Face Gallery, these data indicate that the CFT does not overrule the Level 1 data, suggesting there is no seam in this gallery and that it was built in one episode. This illustrates the hypothesis that the presence of a horizontal seam must be validated by either a vertical seam or the alignment with internal gallery chronological features or episodes.

The second possible scenario is that the NEA east and north faces were built in one phase as they stand now, with fine stonework on the upper courses of the east face and none on the north face. This is contradicted by the presence of the East Face North Staircase south of the East Face Gallery entrance. The East Face Gallery entrance is centered in the NEA east face. The East Face North Staircase sits south of this entrance, centered not with respect to the east face of the NEA, but to the east face of the combined NEA and MA. As will be addressed further below, this suggests that this staircase was added to the east face of the NEA with the addition of the MA, rather than included in its the initial construction. This would indicate that the NEA east and north faces could not have been built in one phase as they stand now.

The final and most plausible scenario is that the NEA east and north faces were initially built to full height with coarse stonework, along with the East Face Gallery and Escalinata. In a later phase, the rough stonework of the east face was deconstructed so that it could be reconstructed with fine coursework and a staircase centered in the new east face consisting of the NEA and the new addition to the south.

Thus, the CFT in the NEA does not mark a horizontal seam that divides the overall construction of the NEA and its galleries into two phases. It does, however, chronologically mark the deconstruction of the east face and its reconstruction with fine stonework as well as a new staircase, adapting the east face to be symmetrical with respect to a new addition.

NEA spatial relationships relevant to construction sequence

A complicating factor in determining the construction sequence of the NEA is the fact that its highest levels are eroded and not well-preserved. The original height of the building can be hypothesized with information from its architecture and that of adjacent additions. The relationships of the galleries in the NEA suggest that the top surface of the NEA above them was the same height. The north and east faces of the NEA must have been of equal height at the north east corner. It does not appear plausible that a platform stepped down to the south from Escalinata, creating a step in the east face, given that Zanja overlaps the elevation where this step would be. There is no evidence that Zanja was in a raised platform of some sort. Since they were built at the same time, it follows that the East Face Gallery originally was built to the same height as Escalinata, and that in some form it reached the top of the platform. This is consistent with the East Face Gallery Level 1 analyses, showing it originally climbed higher than presently. The original height of the NEA above these galleries likely sat above the present level of the top of Escalinata, given that its top is eroded. A more precise estimate is possible after examining adjacent additions to the NEA.

Zanja and Alacenas sit at different levels. Given no other evidence to the contrary, this would suggest they likely were built at the same time. However, Alacenas appears to have been built so that one of its vents was centered within the Escalinata south wall. Its depth appears to have been guided by the need for a vent in this location. The construction and the placement of the gallery such that the east vent opens directly to the center of the relieving window of

Escalinata highlights the importance of this vent's placement. Zanja, on the other hand, may have followed the more standard pattern that galleries tend to be near the surface, also entered from a descending staircase. If the original NEA surface above Zanja and Alacenas was at the same level, their entrances would have sat at the same level. This suggests that the south entrance staircase to Alacenas ascended higher to the south than at present.

The long, south entrance staircase to Alacenas appears to have been blocked by a later addition to the NEA. The difficulty of the resulting modification to the gallery, requiring major deconstruction and reconstruction of the east segment, suggests that this entrance was built not simply to add another functioning entrance to the gallery. The extent of modification suggests that the south entrance was made inaccessible and an alternate entrance was required.

The High NEA, a platform that sits on top of the NEA set back from its north and east faces (Figure 3.1), appears to have been the addition that blocked the south entrance to Alacenas. The north edge of the platform sits approximately a half-meter south of the current south extent of the Alacenas south entrance stairway. With the addition of the High NEA, the south stairway would have been blocked and rendered useless, necessitating the construction of the east entrance. This hypothesis that the High NEA was a later addition to the NEA is explored below.

Construction of the NEA

The above data suggest the following scenario for the construction of the NEA. First, the NEA was originally built as a flat platform with walls of coarse stonework. All its galleries were built at this time. The platform likely was built to the full height of Escalinata, which climbed up and possibly to the south farther than at present (investigated below). The northwest corner, currently marked by A-N-1, extended this high as well, as did the East Face Gallery and the north and east faces (and presumably the south and west faces as well, which are now embedded in Building A). Zanja was included in this platform, with its stairs likely ascending to the nearby

platform surface. Alacenas was placed more deeply than Zanja within the building, likely to connect its vent with the center of the relieving window of Escalinata. Alacenas originally contained only one entrance, opening to the south via a long set of covered stairs that ascended higher than those visible today, to the top of the platform. At later points, the following changes were made: 1: the top of the northwest corner was deconstructed and modified to make room for the northeast vent and east segment of Upper Laberintos and the east segment of Upper Pasos Perdidos, as examined below; 2: the top of the east face coarse stonework was removed and replaced with fine coursework and the East Face North Staircase; 3: the High NEA was built south of Alacenas, and a new entrance to Alacenas was built; this addition blocked the Alacenas south entrance and rendered it inaccessible, necessitating the modification of the east segment and the construction of an east entrance; 4: a free-standing rectangular structure was built on top of the High NEA as part of a different phase, as discussed below. The ways these changes in the NEA articulate with adjacent areas are examined below.

Implications

A number of patterns begin to emerge in this analysis of the NEA. For example: galleries and the exterior are modified after their initial construction to accommodate larger-scale changes to the surrounding temple area, and external features do not tend to overrule the Level 1 evidence and conclusions. Additionally, galleries and internal features are interrelated, as in the building of Alacenas so that its vent is centered in the Escalinata relieving window. This suggests a high amount of planning before construction, and planned relationships between galleries. It also suggests that perhaps, all other things being equal, galleries are built as close to the surface as possible, but when a gallery needs to connect with another gallery via vents, its depth is adjusted to do so.

Centered staircases play a prominent role. For example, both Escalinata and the East Face Gallery are centered in their respective faces. Escalinata was designed to be extremely large and grand, displaying relatively sophisticated engineering techniques of tie beams and relieving windows to support the heavy loads. The East Face Gallery is an example of a hanging staircase.

One of the clear lessons emerging from this study of the NEA is that the construction of this area was not isolated. Its construction phases were not independent from those of other temple areas. Remaining questions about the NEA and new relationships await to be addressed with the analysis of other areas of the temple.

Building A – Northwest corner (NWA) and middle section (MA)

Delineation of the NWA area

The next areas in Building A to be examined are the northwest corner of A, called the NWA, and the middle section of A, called the MA. (For the following discussion, please refer to Figures 4.28-A - 4.32-A, 4.33 - 4.39). These comprise the area between A-E-1 and A-E-2 on the east face, the area west of A-N-1, and the area north of A-W-1 on the west face. On the west face, the area has no obvious north boundary because no other seams have been identified on the west face of Buildings A, B, or C; the NWA therefore is defined as extending as far north as the seam Lab-E-1 in the Laberintos Gallery. The NWA thus includes the area bounded by the A-N-1 to the east, the north wall of Cautivos to the south, and the Lab-E-1 seam to the north; it encompasses Upper Laberintos, Upper Pasos Perdidos, the Marino Gonzalez Staircase, Murcielagos, and Gallery XIII. The MA is defined as the area between seams A-E-1 and A-E-2 on the east face, and between A-W-1 and the north wall of Cautivos on the west face; it includes the Cautivos Gallery, the Liticos Gallery, the Portada Gallery, and the Columnas-Vigas Gallery.

Many of the internal seams identified in the Level 1 analysis are located in the galleries of the NWA-MA area. Three vertical seams lie in Laberintos, one between Upper Laberintos and

Lower Laberintos, and two separating Upper Laberintos from the Alcove. A seam lies along the north wall of Cautivos, chronologically separating the construction of Cautivos against this wall from the original construction of Murcielagos and Gallery XIII. More seams lies in Columnas-Vigas -- a set of seven seams along its north wall and another containing red plaster, which, combined with other areas of modification in the gallery, divides the gallery into north and south episodes. Another seam sits at the base of the Portada and its intersection with Doble Mensula, as mentioned above. Two likely horizontal seams are also present, one at the top of the stairs between Lower and Upper Liticos, and the other above the second landing of Portada; these two seams will be investigated further here.

NWA Gallery-to-Gallery Relationships

Spatial and chronological relationships between NWA galleries

The five galleries in the NWA area overlap in elevation and are not divided by external seam or internal seams, suggesting that they were built in one phase.

As discussed in Level 1 analysis, Upper Laberintos and Upper Pasos Perdidos were clearly built at the same time; a south-trending vent from Upper Laberintos intersects Pasos Perdidos with no seams, possibly as a functional unit as hypothesized by Lumbreras et al (1976), indicating they were built in the same episode. This vent and two similar south-trending vents in Upper Laberintos lie at the same level as the floor of Murcielagos. The top half of Upper Laberintos overlaps the lower half of Murcielagos in elevation; Pasos Perdidos spans the elevations of both galleries, extending both higher and lower than them. Taken as a whole these relationships suggest that Upper Laberintos and Upper Pasos Perdidos were built at the same time as Murcielagos. This conclusion corresponds with the available external data indicating no external seams exist here, suggesting this area was built in one phase.

Supporting this conclusion is a detail inexplicable inside Murcielagos yet clear in the CAD model: the east side segment of the gallery is raised a step above the floor of the rest of the gallery. The west-most south-trending vent from Upper Laberintos passes just beneath the floor of this segment. Rather than building the vent through the gallery, the builders must have chosen to build the floor of this segment just above the vent. The proximity of these two features is consistent with the conclusion that they were built within the same phase.

Gallery XIII appears to have been built at the same time as Murcielagos, and thus as Upper Laberintos and Upper Pasos Perdidos. It lies just to the north of the wall containing the Murcielagos entrance (the north wall of Cautivos), and no seams exist along the north wall that would separate it from Murcielagos. The vertical shaft in Gallery XIII extends higher than the ceiling of Cautivos and likely drained the same high platform as Pasos Perdidos, as their vertical shafts ascend to approximately the same height. Presently, access to the shaft is through what appears originally to have been a vent that opened south to the exterior before Cautivos was built.

The Marino Gonzalez Staircase lies directly west of Upper Laberintos. Its elevation spans the area from below Lower Laberintos to above Upper Laberintos, with no apparent seams separating it from the rest of the galleries of the NWA. It therefore appears to have been built at the same time as Upper Laberintos, Upper Pasos Perdidos, and Murcielagos.

The axis of the long segment in Murcielagos is skewed with respect to the other galleries and the exterior, and the side segments in Murcielagos are skewed with respect to each other.

Spatial and chronological relationships between MA galleries

Level 1 analyses of the Portada gallery and the Liticos Gallery revealed that horizontal seams like exist in each. Comparison of the elevations of these possible seams indicates they align at the same level. They also align with the level of the floors of both Cautivos and Columnas-Vigas. This indicates that the two internal horizontal seams are part of a larger horizontal seam. The gallery segments below the seams were built first, followed by the

construction of the upper segments of the gallery above the seams. The fact that the seams also align with the floors of Cautivos and Columnas-Vigas suggests that a platform containing Lower Líticos and Lower Portada existed at this level prior to the construction of these galleries and Upper Líticos and Upper Portada on it. The floors of these galleries are the former top surface of the exterior platform level of the MA that led up to the entrance to Murcielagos. The coursing changes in these two galleries thus indeed do mark seams that divide the galleries into Lower Líticos and Upper Líticos, and into Lower Portada and Upper Portada.

Cautivos, Upper Líticos, Upper Portada, and South Columnas-Vigas are built strikingly close together, and some of their segments closely interweave in a way not seen between other galleries. This and the fact that their floors align on the same horizontal plane suggest that these galleries were constructed at the same time on the platform marked by the horizontal seams at the tops of Upper Líticos and Upper Portada. Following the chronology of Columnas-Vigas the Columnas Patio would have been built with these galleries and covered in a later phase.

The north walls of Cautivos and Vigas align in an east-west plane and contain no batter.

Spatial and chronological relationships between NWA and MA galleries

Cautivos was built after Murcielagos, as shown in the previous chapter; it was abutted against the south-facing exterior wall containing the entrance to Murcielagos, after modifications to the top of this wall. Cautivos therefore was also built after Upper Laberintos, Upper Pasos Perdidos, and the Marino Gonzalez Staircase, since these were built in the same phase as Murcielagos.

Spatial relationships suggest that Upper Laberintos, Lower Líticos, and Lower Portada were built in the same phase. Lower Líticos and Lower Portada sit on the same level as Upper Laberintos, and no seams separate the galleries. A vent connects the south wall of intersection KL in Upper Laberintos to the north wall of Lower Líticos Segment I, trending southeast and spanning 24.89 m. This and the other south-trending vents from Upper Laberintos pass

underneath the level at which Cautivos, Upper Líticos, Upper Portada, and Columnas-Vigas sit. Upper Laberintos was built before Cautivos, and both Lower Líticos and Lower Portada were built before Upper Líticos and Upper Portada, which are on the same level as Cautivos and likely built at the same time.

From these relationships three chronological groups can be hypothesized and readdressed below: the first chronological group contains Upper Laberintos, Upper Pasos Perdidos, the Marino Gonzalez Staircase, Murcielagos, Lower Líticos, and Lower Portada, while the second chronological group contains Cautivos, Upper Líticos, Upper Portada, and South Columnas-Vigas along with the Columnas Patio. The third group consists of the covering of the Columnas Patio to construct North Columnas-Vigas.

NWA Gallery-to-Exterior Relationships

The stonework of the exposed west face of the NWA-MA area has been almost completely stripped, revealing the stone fill (Figures 4.40 - 4.45). Much of the face sits buried beneath at least five meters of fill, as indicated by Rick's excavations at A-W-1 (Rick et al. 1998). Three vents are evident in the stone fill, connecting to Cautivos and likely Gallery XIII. No other vents are clear, such as any from Murcielagos or Laberintos, all of which when measured from inside the galleries are found to be collapsed. The Marino Gonzalez Staircase is clearly visible in the west face, and as explained in the Level 1 analysis, the original floor of its entrance would have extended below present ground level. In the MA, one fine stone of the tenon head course connects with the tenon head course of the SA. This course is visible on the south face above the bottom doorway to Lower Portada, at the level where the Lower Doble Mensula Gallery abuts above the doorway (Figure 3.431). It also aligns with the pegs in the Upper Laberintos Gallery.

On the east face of the MA, original stonework is also largely absent, primarily due to the large historic-period excavation that destroyed much of the face. The original stonework that does

exist is rough (Figures 4.10, 4.46) laid out in an ABB pattern amid patched areas. Stonework at the level above the CFT is poorly preserved. The galleries of the MA all lie above the level of existing exterior stonework.

The columns in the Columnas-Vigas Gallery are offset from the columns of the Black and White Portal. The midpoint between the columns in Columnas-Vigas sits approximately 3.37 m north of the midpoint of the Black and White Portal, between its columns.

On the north face of the NWA, the Lab-O-1 seam in Laberintos aligns with the north face of the NWA and the NEA, indicating that the wall broken through in the Laberintos Alcove was an exterior wall, a conclusion consistent with its ABB coursing and Level 1 analysis. This indicates that the exterior wall of the NWA originally extended at least as far west as the Lab-O-1 seam; today this wall is largely buried and is visible only near A-N-1. Whether it continued through to the west wall is unclear and will be discussed more below. The exterior wall that comprises the Lab-O-1 seam must have been built at the same time as Upper Laberintos, because it forms the external wall to which vents from Upper Laberintos extend without seams. The exterior wall must have terminated above the level of the stairs of Upper Laberintos, because the stairs extend beneath and north of the exterior wall.

The low entrance to Lower Portada is centered in the south face of the MA. The east edge of its doorway is 35.40m from the east face of the temple, while its west edge sits 35.90m from the west face of the temple.

Relationships with external seams

Seam A-E-2

Seam A-E-2 aligns with the doorway to Lower Portada from Lower Doble Mensula and the clear abutment seam, DM-A-1, located there. This alignment of the internal and external seams here was hypothesized by Tello (1960). In profile, the seam on the east face is located completely below the interior doorway, while the seam on the west face extends high enough to

be at the same level as the doorway. The two external seams and the internal seam align along a plane.

As revealed in excavations by Rick (Rick et al. 1998) and discussed above, A-E-2 does not extend all the way to the foundation but terminates at a low platform. This platform is continuous with the MA area to its north, indicating they were part of the same construction.

Seam A-E-1

Both Rowe (1961:95) and Lumbreras & Amat (1969:148) postulated that the north walls of Columnas-Vigas and Cautivos were former external walls of the Old Temple that align with the A-E-1 seam. Analyses here confirm that these walls indeed were external walls, but indicate that they do not align with A-E-1 and were not part of an “Old Temple.” Rather, the galleries cross over the plane of the A-E-1, which does not align with their north walls but sits approximately 2.06 m to the south. The seam currently terminates 5.80 m below the galleries, due to missing external stonework. Even if the seam continued up to the elevation of the galleries’ floors, following the northward slope up of its batter, its highest point would sit approximately 1.50 m south of the north wall. Consistent with these relationships is the fact that the north walls of the galleries do not contain batter, unlike the north seam on the east face. This suggests that A-E-1 and thus the top of the NEA at this corner were no taller than the floor of these galleries. It also indicates that the galleries were built up against the face of another platform that was not necessarily built at the same time as A-E-1.

West face, opposite A-E-1

As discussed in Chapter 1, on the west face of Building A no seam exists directly opposite A-E-1, indicating that A-E-1 does not extend through the whole temple as the south seam does between A-E-2 and A-W-1 (Rick et al. 1998). The absence of a seam at this point in

the west wall suggests that A-E-1 terminates at what originally would have been the southwest corner of the NEA, now buried by later constructions (Rick et al. 1998).

The construction of the north wall of the Cautivos Gallery and its proximity to the west face, however, suggest that a vertical seam did exist on the west face, but at the level of the gallery. This seam would have aligned not with A-E-1, but with the north wall of Cautivos, and would have sat at the corner where the west face met the south-facing outer wall containing the entrance to Murcielagos. The seam would have been formed when Cautivos and its corresponding exterior wall were built up against this corner and the south-facing outer wall. A horizontal seam would be created where Cautivos was built on surface at the entrance to Murcielagos. These seams are not visible on the exterior because the exterior stonework is missing at this level.

When Tello discovered the Cautivos Gallery he did so through the west wall, where the exterior stonework no longer existed, exposing the west end of the gallery (Tello 1960). The west end of the gallery was later reconstructed by Marino Gonzalez (personal communication, 1998; Gonzales and Rick video interviews).

Seam A-N-1

On the north face of Building A, the top of A-N-1 terminates at the base of the external vent connecting to Segment G of Upper Laberintos, with the stonework of the NEA sitting east of the seam and later stonework sitting west of and above the seam. The plane defined by A-N-1 trends north-south through the middle of Segment G in Upper Laberintos and through Segment D of Upper Pasos Perdidos. Segment D of Upper Pasos Perdidos extends east past the plane of A-N-1 into the NEA, continues ascending to its maximum height where it intersects a roof canal, and then descends and curves towards the north. The seam is not evident in the internal construction of either gallery.

The location of A-N-1 with respect to Upper Laberintos and Pasos Perdidos suggests that the west wall of the NEA was deconstructed to accommodate Upper Laberintos Gallery and

Upper Pasos Perdidos. Construction of the galleries would have required removing the top courses and fill layers of the north west side and corner of the NEA. In this gap the east extents of the new galleries would have been built. Their construction across this newly deconstructed area would cause seams marking the continuation of the Rowe' seam south not to be present; the new structures would simply have been built across the plane. Thus the absence of A-N-1 in the gallery or the canal is consistent with this hypothesis.

The fact that Segment D in Upper Pasos Perdidos curves and descends to the north within the NEA suggests either that it was built to connect with something such as a drain that already existed in the NEA, or that the NEA was deconstructed even further to accommodate the construction of Segment D to the north and east. The former possibility may be part of the answer to why this corner of the NEA was deconstructed in the first place, but a full explanation is not evident.

Construction of NWA-MA area

The facts that the Cautivos Gallery was built after the Murcielagos Gallery and that the entrance to Murcielagos sits in the wall now forming the north wall of Cautivos suggest that the area south of Murcielagos originally was an open surface. The location of the doorway to Murcielagos just above the level of the present floor of Cautivos suggests that a platform existed at or near the present level of the floor to Cautivos from which the doorway could be reached. This suggests that Cautivos was built directly upon this platform, creating a horizontal seam at the base of Cautivos along with the vertical seam along the north wall. The stairs down into Cautivos appear to be well integrated with the north wall, suggesting that they originally were part of this north wall and led down to the open platform and the Murcielagos entrance before Cautivos was built. This whole scenario suggests that the wall containing the entrance to Murcielagos marks the

south wall of a raised platform that stepped down to the level of a platform from which Murcielagos was entered.

The north wall of this platform aligns with the north edge of the raised platform of the NEA. It sits between the south wall of Upper Laberintos and the vertical shafts of Pasos Perdidos. This raised stepped platform, here named the High NWA, thus incorporates Murcielagos and Pasos Perdidos south of Upper Laberintos. The north wall of the Columnas-Vigas gallery marks the former south wall of a comparable raised platform on the NEA, named the High NEA above.

The vertical seam along the south walls of the Murcielagos and NEA platforms, and the alignment of the horizontal seams in Liticos and Portada with the floors of Cautivos, Columnas-Vigas, and Upper Liticos, suggests there also was an open platform at the level of those horizontal seams, from which Murcielagos could be entered and on which Cautivos, Columnas-Vigas, Upper Liticos, and Upper Portada were later built. This platform is here named the MA. It sat south of the Murcielagos and NEA raised platforms, and contained Lower Liticos and Lower Portada, which were entered from the top of the platform. The galleries built above it are grouped as the High MA.

Two lines of evidence suggest that the High NWA and the NEA raised platform were constructed at different times. First, as shown in the Level 1 analysis, the stonework of the north walls in Cautivos and Columnas-Vigas is extremely different. This indicates that the stonework of the platforms was different and suggests that they were built at different times. Second, the entrance to Murcielagos is centered between the west face of Building A and the plane of A-N-1 to the east, measuring 16.40m from the west side of the doorway to the west face and 16.37m from the east side of the doorway to the plane of A-N-1. This suggests the plane of A-N-1 marked a division between the two platforms and their different wall types, supporting the hypothesis that they were built at different times and suggesting that the High NWA with its centered doorway was built before the High NEA. A-N-1 cuts Building A approximately in half, meeting A-E-1 to form the southwest corner of the NEA, just south of the platforms' south walls.

The seam at the base of Lower Portada and the south seams on east and west faces (A-E-2 and A-W-1) with which it aligns indicate that MA stepped to the south here, to the level of the SA Platform. The bottom doorway of Lower Portada thus opened directly to the south face. It was centered in this south face, measuring 35.90 m to the west face from the west side of the doorway and 35.40 to the east face from the east side of the doorway. The fact that the seams continue down to the SA Platform on both east and west faces indicates that the south face below the Lower Portada doorway also continued down to this level; no other data contradicts this or suggest that some sort of platform existed underneath the doorway to the south, above the SA Platform. Lower Portada therefore appears to have been a hanging staircase, opening to the south face. It contains the same right-angle bend as other hanging staircases, as seen in the East Face Gallery and other staircases to be described below.

The High NWA and the High NEA form a continuous platform that is effectively centered across the length of the NWA-MA, which measures 47.58m north to south. The distance from the north face of the High NWA and the High NEA to the north wall of the Building A measures 13.39m, while the distance from their south faces to the south face of the MA measures 15.27m.

Bringing together these elements, the construction sequence of this area is the following:

1: The NWA, High MA, MA, and SA platform are constructed in one phase, here named the NWA-High NWA-MA-SA Platform phase. This includes Upper Laberintos, Upper Pasos Perdidos, Marino Gonzalez Staircase, Murcielagos Gallery, Gallery XIII, Lower Liticos Gallery, and Lower Portada Gallery. This construction forms a set of stepped platforms, with the High NWA raised and set back along the west wall, centered in the NWA and MA, with a lower platform to the north, east, and south at the level of the horizontal seams in Portada and Liticos (Figure 4.47).

2: The High NEA is constructed against and east of the High NWA, aligning with it but built with different exterior stonework.

3: The High MA is constructed, including Cautivos, Upper Liticos, Upper Portada, and South Columnas-Vigas with the Columnas Patio.

4: The Columnas Patio is covered with the construction of North Columnas-Vigas.

The relationships of these phases with neighboring areas will be investigated below.

Implications

A number of implications can be drawn from this Level 2-3 analysis. For example, this analysis further illustrates the hypothesis that alignment of internal features confirms the presence of horizontal seams, as in the case here of the horizontal seams in Liticos and Portada.

Additionally, the prominence of the Portada doorway, centered in the south face of the MA and constructed of fine stonework, highlights the importance it must have been given. It originally appears to have been a hanging staircase, and will be investigated more below. The analysis also suggests that the south wall of the High NWA, containing the entrance to Murcielagos, is built in the same phase as the south face of the MA, which houses the Lower Portada doorway on the south face. The stonework between these two walls differs, however: the south wall of the High NWA is built with rough stonework, while the south face of the MA is built of fine stonework.

Looking at the galleries themselves, an interesting pattern begins to emerge. Within the NWA, Upper Laberintos and Murcielagos were built at the same time, but their forms are extremely different: the form of Upper Laberintos is regular and appears to be highly planned and elegantly designed, while the form of Murcielagos is much less so, with its main hallway skewed relative to the plane of the wall of its doorway, and the side hallways skewed relative to the main hallway and to each other. It appears loosely and almost haphazardly planned, particularly when compared to Upper Laberintos. Taken as a whole, the construction of both of these galleries is seems innovative: Upper Laberintos with its interweaving segments, rooms, vents, and even drainage canal in the form of Pasos Perdidos; Murcielagos with its stacked rows of vents

connecting the side segments, its tall, narrow proportions, its vent exiting through the staircase, along with its skewed angles. These two galleries are drastically different in form and design, yet both contain innovative forms and features not seen in other galleries – and they were built in the same phase. In contrast, the galleries in the High MA phase contain less variability, seem more “standardized.” Their forms are regular and planned, as in Upper Laberintos, but are much more similar to each other than those within the NWA-High NWA-MA-SA Platform phase. The gallery segments intertwine with each other, and even the space between the galleries and gallery segments appears to be standardized. Less variability and less innovation exist within and between the galleries of this phase than those of the NWA-High NWA-MA-SA Platform phase. Standardization of gallery forms and construction begins to emerge as a pattern in this area. This pattern will be discussed further below.

Looking beyond the galleries to the isolated phases, the NWA-High NWA-MA-SA Platform phase is an extremely large construction in both volume and area, much larger than the NEA. It appears to be the first phase to follow the NEA in Building A.

NEA-NWA-MA relationships

The main platforms of the NEA and the NWA sit at the same level. In the NEA, this platform forms the south edge of the NEA that sits at the floor of the High MA galleries, immediately south of the High NEA; this gives the maximum height for the NEA to which the Escalinata and East Face Gallery likely originally climbed, and from which Alacenas and Zanja likely were entered. The High NEA was built on top of this level. In the NWA at this level lies the platform from which Murcielagos was entered, which now forms the floor of Cautivos in the High MA. This level is also very close to the present top of the Marino Gonzalez Staircase, and sits above the level of Upper Laberintos. This level formed a stepped platform with north and south of the High NWA.

The surface of the MA aligns with the level of the top of the NEA and the NWA. The MA was built to the original level of the NEA, forming a larger continuous platform. Over this level the High NEA was built, essentially centered on the MA-NEA platform. This centeredness indicates the High NEA was built after or at the same time as the MA was abutted to the NEA. The Alacenas south entrance likely climbed all the way to the top of the NEA. With the building of the raised High NEA, its entrance was blocked, and thus the east entrance was necessitated. The centeredness of the Murcielagos doorway in the High NWA suggests that the High NEA was built after the High NWA; this is consistent with the different stone types in their north walls. Upper Liticos was built away from the south face of these platforms likely because Lower Liticos already existed to the south in the MA. Some time after the construction of the High MA, North Columnas-Vigas was built up against the south wall of the High NEA, at the same level as the north base of the platform, south of Alacenas.

The bases of the Marino Gonzalez Staircase (as estimated in Level 1 analysis) and of the East Face Gallery sit at the same level. The possible significance of this is discussed in Chapter 7.

The East Face vent lies directly east of only the intersection in Upper Pasos Perdidos, yet this relationship is not significant because they do not connect. Perhaps the East Face Gallery vent connected to another gallery that has not been found, or perhaps it intersected a vertical drain.

SA- South end of Building A

The south end of Building A, or the SA, is defined as the area south of the A-E-2 and A-W-1. This includes the Lower Doble Mensula Gallery, the Upper Doble Mensula Gallery, the Caño Gallery, the East Face South Staircase, and the South Face Staircase (Figure 4.48-A, Figure 4.49).

SA Gallery-to-Gallery Analysis

Gallery-to-gallery analyses suggest that the Caño Gallery was built at the same time as Lower Doble Mensula, and that both of these were built before Upper Doble Mensula. They also suggest that the top of a platform containing the Caño Gallery and Lower Doble Mensula was deconstructed to accommodate the construction of Upper Doble Mensula.

The seam separating Lower and Upper Doble Mensula indicates that Lower Doble Mensula was deconstructed to accommodate the addition of Upper Doble Mensula, as shown in Level 1 analysis. This deconstruction corresponds with overlap between the galleries' elevations. The elevation of the floor of Upper Doble Mensula sits between 0 and 0.9m below the ceiling level of Lower Doble Mensula, due to variations in the ceiling level in Lower Doble Mensula and its various mensula layers. This overlap in elevations between the two galleries suggests that part of the fill in the platform containing Lower Doble Mensula was deconstructed to enable the two galleries to connect.

The relationships between these two galleries and the Caño Gallery suggest that the Caño Gallery was built in the same phase as Lower Doble Mensula. The north wall of Caño aligns with the south walls of the side segments in Upper Doble Mensula. Caño vertically spans 7.35 m, beginning 0.87 m above the level of the SA Platform and climbing to the upper reaches of Lower Doble Mensula. The covered top of the vertical shaft in Caño sits approximately aligned with elevation of the top of the first mensula layer in Lower Doble Mensula, and approximately 0.51 m above the present floor level of Upper Doble Mensula. The level of the top of the canal that enters this vertical shaft sits 20 cm below the floor level of Upper Doble Mensula, and sits within the layers of the mensulas in Lower Doble Mensula. These overlaps in the elevations of the Caño Gallery and Lower Doble Mensula suggest the galleries were built at the same time, while the overlap of the Caño Gallery with the bottom of Upper Doble Mensula is consistent with the

possibility that Upper Doble Mensula was dug out of the earlier platform containing Lower Doble Mensula and the Caño Gallery.

SA Gallery-to-Exterior Analysis

Spatial three-dimensional data was also collected on the exterior walls of the SA, locating features to help determine the relationships between the internal galleries and the external stonework (Figure 4.50-A). On the east face these features include the top of the AB coursing, the coarse-to-fine transition (CFT), A-E-2, the east hanging staircase, the remains of the tenon head course, and the wall perimeter (Figures 4.51, 4.1, 4.52 - 4.55). On the south face they include the bottom of the tenon head course, the CFT, the bottom of the A course at the base of the south hanging staircase, vent openings, the top of the AB coursing, and the wall perimeter (Figures 4.56, 4.57, 3.454, 4.58 - 4.62). On the west face, they include the bottom of the tenon head course, the bottom of the cornice course above the tenon head course, A-W-1, the bottom of the second A course below the tenon head course, the vents, and the wall perimeter (Figures 4.63 - 4.67, 4.45).

Comparisons of the SA galleries to exterior stonework were not always possible because much of the upper exterior stonework of the SA is missing and because much of the SA is buried at present, particularly on the west face and the southwest corner. Almost all of Upper Doble Mensula and most of the east end of Lower Doble Mensula sit above the vertical wall perimeter of the south face, while all but the top of Caño Gallery sits below the wall perimeter. With respect to the east face, Lower Doble Mensula and Upper Doble Mensula lie almost wholly above the wall perimeter, and Caño is fully within the wall perimeter. Lower Doble Mensula and Upper Doble Mensula fit largely within the upper and lower wall perimeter of the west face, but most of Caño is below present ground level.

Some courses on the SA, as well as on other areas of Building A, slope rather than lie in a level horizontal plane. The angles of the slopes vary between courses on a single face, as well as within a single course on different faces. The elevations of some of the features therefore vary from face to face, a factor that should be accounted for during analysis. For example, the tenon head course on the east face sits approximately 0.87 m lower than the tenon head course on the west face, due to varying slopes of courses on each face. Courses on the south face, including the tenon head course and the CFT, slope up from east to west. The courses on the west face slope up from north to south, meeting the courses from the south face at their maximum height at the southwest corner. The courses on the east face slope slightly up from south to north, and meet the courses from the south face at their lowest elevation at the southeast corner. Closer to the foundation, however, visible courses, such as the top of the AB coursing, are level.

Caño Gallery and the CFT

The horizontal plane of the CFT in the SA cuts through the Caño Gallery approximately midway between the bottom of the vertical shaft and the exterior opening, in the stepped descending canal. The gallery begins in the coarse ABB coursing below the CFT and crosses the distinct external coursing change with no change or visual marker on the inside. If the CFT marked a horizontal construction seam, the lower half of the canal would have had to have been functional on its own; it clearly is not. Level 1 analysis showed that the Caño Gallery was built in one episode as a complete functional unit. Because the CFT does not align with any transition in interior features, and because the gallery is a functional unit, the CFT likely was not a horizontal seam.

Other features suggest that the coarse and fine stonework likely were built within the same phase in the SA, and that the fine level was not added after a phase of deconstruction, as in the NEA. Because the south face of the MA is in fine coursework, we can infer that the west and east faces of the MA also may have had fine stonework, although they are largely missing and

what remains is poorly preserved. If so, then the fine stonework in the SA likely was built at the same time as the coarse stonework below it, to continue the visual pattern across the length of the temple.

No other internal features cross the CFT in the SA. Lower and Upper Doble Mensula both sit well above the CFT: the uneven floor of Lower Doble Mensula lies between approximately 1.44m and 1.88m above the CFT, and the floor of Upper Doble Mensula sits approximately 4.17m above the CFT.

The canal leading to the shaft of the Caño Gallery may have drained the top of the platform in which it sat, it may have connected with other canals in the SA such as those explored in excavations by Bennett (1944), or it may have connected in some way with a buried gallery in the southeast corner of the SA, reported by Marino Gonzales and Alejandro Espinoza Noceda (personal communication, 1998).

Staircases

The South Face Staircase (Figure 4.68) contains the same form as other hanging staircases, climbing first to the north, then turning and climbing to the west. Its lowest step sits 9.56 m above the foundation level of the SA Platform. The top of the staircase is missing, but the remaining stonework suggest the staircase may have turned and climbed to the north again. Its highest remaining stones sit at a level aligned just below the ceiling of Upper Doble Mensula, 2.91 m above its lowest step. In the course below the base of the staircase, a vent opening connects with the vent on the stairs to Upper Doble Mensula. The exterior vent is lower than and to the east of the interior opening; if the vent had continued straight out, it would intersect the stairs. This suggests this vent may have been designed not to obtrude in the south hanging staircase.

One of the most striking gallery-exterior relationships in the SA is the fact that the South Face Staircase is located at nearly the same elevation and east-west position in the south face of

the SA as the Lower Portada entrance is in the south face of the MA— centered in the south face. The distance from the east edge of the South Face Staircase to the east edge of the south face measures 35.36 m, while the distance from its west edge to the west edge of the south face measures 35.33 m, a difference of just 3 cm over 35 meters. The South Face Staircase is more precisely centered within the south face than the Lower Portada entrance, which is off-center by 0.50 m, as shown above.

The bottom of the East Face South Staircase (Figures 4.69, 4.70) sits a course above the CFT. The top of the staircase is missing, but the highest remaining stones align approximately with the level of the floor of Upper Doble Mensula. The staircase does not appear to align significantly with interior features in plan or profile. It is not centered in the SA: its south edge is 16.33m from the south corner of the temple, while its north edge is 3.20 m from A-E-2, which marks the north extent of the SA. This staircase also bends, turning to the south.

A free-standing rectangular structure sits on top of the northeast end of the SA, approximately 3.45 m above the level of the top of Upper Doble Mensula. It does not align with any of the interior galleries. It is effectively centered over the East Face South Staircase. Its north edge crosses over the plane of A-E-2.

Relationships with the tenon head course

The alignments between the tenon head course and the galleries of the SA suggest that there is no clear horizontal external seam at the level of the tenon heads. As noted above, the tenon head course on the east face sits lower than the tenon head course on the west face by approximately 0.87 m, due to the downward slope from west to east of courses on the south face. The sloped elevations of the tenon head course on the east, south, and west faces span the levels of the mensulas in Lower Doble Mensula and the floor level of Upper Doble Mensula. On the south face, the tenon head course slopes down from west to east and spans the levels of the upper mensula and ceiling layers of Lower Doble Mensula, sitting just above the floor level of Upper

Doble Mensula. The tenon head course on the west face spans the top step of the stairs to Upper Doble Mensula (just below the floor level of Upper Doble Mensula) and the lower mensula layers of Doble Mensula. The Caño Gallery also crosses the tenon head level on the south and east faces; on the south face the top of its vertical shaft sits approximately 0.48 m above the tenon head level, while the top of the high canal sits 0.21 m below the tenon head course . On the west face the top of its vertical shaft sits 0.65 m above the tenon head course , which aligns with the top of the canal; on the west face, the tenon head level sits just 0.11 m above its max height. This lack of a clear alignment suggests that no horizontal seam sits at this level.

Construction of Upper Doble Mensula

As discussed above, the vertical seam between Lower Doble Mensula and Upper Doble Mensula, along with the spatial relationships of the galleries in the SA, suggests that the construction of Upper Doble Mensula required deconstructing part of the top of the SA containing Lower Doble Mensula in order to make room for Upper Doble Mensula, and deconstructing the south wall of Lower Doble Mensula Segment A in order to build a new staircase leading to the level of the new gallery. This process is similar to the deconstruction of the west edge of the NEA to accommodate the east segments of Upper Laberintos and the Upper Laberintos Canal.

The higher the top of the SA originally sat above Lower Doble Mensula, the more substantial the deconstruction would have been to accommodate Upper Doble Mensula. At what level did this surface sit? Reports by Bennett (1944:71-72) of information gathered prior to the 1945 aluvi3n indicate that flat ledge approximately 2.5m wide sat near the level of the cornice present on the southwest corner of Building A. On this ledge was built a platform wall 2.5 m high, behind which earth fill rose another meter to the base of the south free-standing rectangular structure (Bennett 1944:71, 72, Figure 25). The flat ledge and platform walls Bennett describes are no longer evident, likely due to destruction by the aluvi3n. However, from this description, I

hypothesize that the flat ledge may have been the original surface of the portion of the SA containing Lower Doble Mensula, here named the SA, the top of which likely was deconstructed to accommodate Upper Doble Mensula.

The level of the cornice course exists only in very small portions of the west and east faces, near the southwest and southeast corners. Because the courses of the SA slope down to the east and north from their highest point at the southwest corner, as described above, the bottom of the cornice course on the west face lies at an elevation 0.85 m above the elevation of the base of the equivalent course on the east face. This suggests that the top of the SA likely was not level, but rather varied approximately 0.85 m.

How much deconstruction of the SA top surface was necessary to accommodate Upper Doble Mensula? The vertical distance from the bottom of the cornice course on the east face to the ceiling of Lower Doble Mensula measures 0.17 m. The vertical distance from the bottom of the cornice course on the west face to the ceiling of Lower Doble Mensula measures 1.03m. Accounting for the full height of the cornice level and perhaps an additional course or two above the cornice (Bennett's account is not specific, stating the cornice level sits "at about the level of the setback terrace ledge" (1944:71)), the top surface of the SA likely would have sat likely no more than 1.5 or 2 m above the ceiling of Lower Doble Mensula on the west face, and approximately 0.85 m below that on the east face. This means that the full height of Upper Doble Mensula did not fit within the SA: on the west face, the bottom of the cornice course sits 0.60m below the ceiling of Upper Doble Mensula, while on the east face the elevation of the bottom of the cornice level sits 1.43 m below the elevation of the ceiling of Upper Doble Mensula, not including the thickness of the ceiling stones. The highest portion of the gallery and its ceiling would have been above the elevation of the SA. This suggests that the upper part of the gallery was constructed within the platform described by Bennett that was inset approximately 2.5 m from the south wall and rose approximately 3.5m to the base of the free-standing rectangular

structure. This platform is here named the High SA. The elevation of the top of the SA in relation to the elevation of the MA, NEA, and NWA is investigated further below.

Analysis of the SA suggests that the South Face Staircase and the East Face South Staircase originally climbed to the top of the SA. The remains of the South Face Staircase currently climb to within 0.18 m of the bottom of the cornice level. The depth between the remaining top of the staircase and the south face is 2.58 m, suggesting that it fit within the ledge described by Bennett. Though close in proximity, it does not appear that the South Face Staircase and Upper Doble Mensula connected with each other.

The original south wall of Segment A in Lower Doble Mensula may have contained a south facing vent, as do the other south facing segments in the gallery; with the deconstruction of this wall and the construction of this staircase, this vent likely was maintained as the vent in the middle of the stairs up to Upper Doble Mensula. If so, its opening on the south face is likely original, and thus the South Face Staircase above it likely is too, since the direction and slope of the vent seems to be diverted so that it does not open in the South Face Staircase. This suggests that the South Hanging Staircase was originally built at the same time as Lower Doble Mensula, when Lower Doble Mensula blocked the formerly external doorway of Lower Portada. This in turn suggests that the South Face Staircase was built before Upper Doble Mensula.

The alignment of the free-standing rectangular structure centered above the East Face South Staircase suggests that the structure was built in a phase after the SA; this issue and the reasons for this conclusion are discussed more later in the context of Building A as a whole.

Construction of the SA

The above analyses suggest that the SA was built in the following four phases:

1. The SA Platform Phase is built as part of the construction of the MA and the NWA.

2. The SA Phase is built above the SA Platform, containing the Caño Gallery and Lower Doble Mensula. The East Face South Staircase and the South Face Staircase are built in this phase. The South Face Staircase replaces the Lower Portada entrance in the MA as the centered staircase in the new south face of Building A. The tenon head and cornice courses are included in this phase. The elevation of the top of the SA likely sits slightly above the level of the cornice course.
3. The High SA Phase is built above the SA, containing Upper Doble Mensula. Part of the surface of the SA is deconstructed in order to accommodate the bottom of Upper Doble Mensula so that it connects via a staircase to Lower Doble Mensula.
4. The south free-standing rectangular structure is added on top of the High SA phase.

Relationships within Building A

The ventilation system and its chronological implications

The vents in Building A provide important information regarding the construction sequence by showing us how galleries connected via vents, how those vents were blocked individually or in groups by later constructions, and how the construction of galleries was planned with respect to the placement of individual vents.

Vent relationships with seams

A set of vents extends north-south across the length of Building A (see Figures 4.71 - 4.74). These vents begin in the north face of Building A outside Upper Laberintos and connect to the south face of Building A, passing through galleries and the south seam marked by A-W-1 and A-E-2 on the way. The vents in the north face of Building A pass through the north wall of Upper Laberintos and connect with three major south-trending vents via a set of segments and internal

vents within the gallery. The west vent in Upper Laberintos passes directly beneath Segment C of Murcielagos and connects with the north west corner of Doble Mensula, spanning a total of 38.55 m. The middle vent in Upper Laberintos connects with Lower Liticos and then with Segment B of Lower Doble Mensula. The east vent in Upper Laberintos spans 38.55m, passing through Upper Pasos Perdidos and then continuing on to Segment B of Lower Doble Mensula. The vent in the staircase of Murcielagos trends south to the upper corner of the northwest corner of Segment B in Lower Doble Mensula. Each of these vents originates in the NWA and passes through the south seam plane marked by A-E-2 and A-W-1; they therefore opened to the south face of the MA before the SA was built. Once they open to Lower Doble Mensula, vents in the south and west walls of the gallery continue to the exterior.

Some of the vents that originally opened to the south face of the MA do not continue through the south seam. These inform us about the chronological relationships between galleries. The vent in the south wall of the Portada Gallery is blocked, as is one of the vents in the south wall of Lower Liticos. This latter vent is particularly interesting because it sits in close proximity above another vent that does continue through the seam to Lower Doble Mensula. The lower vent continues through Lower Doble Mensula, while the upper vent goes the same distance but appears to dead end without a vent or evidence of a former vent in Lower Doble Mensula. This suggests that the upper vent was blocked when Lower Doble Mensula was built. Why these two vents originally were built so close together is unclear; what is clear is that only one of them was allowed to open into Lower Doble Mensula. This suggests that Lower Liticos was built first, with these two vents trending south, and then Lower Doble Mensula was built later, blocking the top vent. This corresponds with the conclusion that the MA, in which Lower Liticos is located, was built before the SA, in which Lower Doble Mensula was built.

The vents of galleries in the High MA are particularly informative about the chronology between the High MA and the High SA. Because the upper reaches of the exterior no longer exist, the full vertical extension of the A-W-1 is not known. Currently it climbs approximately to

the level of the top of Lower Doble Mensula. Based on this evidence alone, there would be little reason to suggest separating the High MA and the High SA as distinct phases. A set of vents trending south from the galleries of the High MA, however, provide additional evidence. They either terminate or suddenly shorten along a plane that is coplanar with A-E-2 and A-W-1. This set of vents consists of four vents in the south walls of Upper Liticos, and two vents in the south wall of Segment M of South Columnas-Vigas. The four vents in Upper Liticos terminate at the plane, while the vents in South Columnas-Vigas narrow in height and its east-most vent even curves east at this point. A fifth vent in Upper Liticos continues through the plane, extending south over Lower Doble Mensula, and a third vent in Columnas-Vigas is collapsed. This plane aligns with the continuation of the plane of A-E-2 and A-W-1. This indicates that the High MA contained a south face along this plane. The fact that the vents terminate or narrow in height along this plane indicates that the building phase to the south, the High SA, was built later, abutting against the original south exterior wall of the High MA. The plane along which the vents terminate or shorten exhibits the same batter as the lower portions of the seam, indicating that the south exterior wall was battered and thus likely was built before the High SA phase. Consistent with this is the fact that the south-trending vent from Low Portada also terminates at this plane, as does an excavated area in the south wall of Portada. Thus the vents indicate that Upper Doble Mensula and the High SA were built after the High MA and its galleries.

Placement of Galleries and vents: patterns and chronological implications

The vent relationships in Building A suggest that the placement and form of galleries was dictated in large part by the need to accommodate and continue south the vents from earlier galleries to the north. For example, in Segment B of Lower Doble Mensula, a small vent in the very upper northwest corner of the gallery connects with the south vent from the Murcielagos staircase. This suggests that the west extent of Doble Mensula was planned and built to accommodate this one small vent, so that the two galleries would connect.

With the completion of Building A, as a group all galleries in the NWA, MA, and SA are connected by vents, except Caño and the Marino Gonzalez Staircase which are a drainage canal and staircase respectively, forms that do not regularly have vents. Vents are continued through each successive phase, and the placement and form – and therefore the function to the extent it relates to placement and form – of some galleries are determined by the placement of earlier vents and the need to continue to connect some of these to the exterior.

The galleries in the NEA, the earliest phase of Building A, are not part of this interconnected vent system. Vents do exist and already play an important role within the NEA, however. The placement of Alacenas within the NEA is guided by the need for a vent to open to the middle of the south wall of Escalinata, visible to the exterior through Escalinata's relieving window, as discussed in Level 1 analysis. In the NEA, then, vent placement appears to be planned and plays an important role in gallery construction.

Chronology of MA-SA

Analysis of the relationships of the galleries and vents in the MA and the SA suggests that the level of the top of the SA likely aligned with the level of the top of the MA. Although the level of the top of the SA slopes down from the southwest corner, as discussed above, courses on both sides of A-W-1 align, suggesting that the platform surfaces spanning the seam would have been smooth, at the same elevation. This elevation corresponds with the elevation of the top of the NEA, and the elevation of the NWA north of the High NWA. In other words, the elevation of this platform is consistent across Building A, unifying each area of the building into a consistent whole.

Based on the above relationships, the MA was built before the SA, and the High MA was built after the MA but before the High SA; the question remains, then: which came first, the SA or the High MA? If the High MA was built before the SA, a very tall south face to the MA was

created, consisting of both the MA and the High MA. This does not follow the stepped platform pattern that emerged in the NWA-High NWA-MA-SA Platform phase. If instead the SA was built before the High MA, a long higher platform was created at the level of the MA, with the South Face Staircase replacing the Lower Portada doorway as the centered hanging staircase on the south face. This would leave the joined High NWA-High NEA stepping down to a larger platform extending to the south end of Building A, following the stepped platform pattern. The later addition of the High MA to this would continue to the south the stepped platform pattern begun with the High NWA-High NEA, covering the now off-center Murcielagos entrance in the south face of the combined High NWA-High NEA. Because this last option follows a consistent stepped platform pattern, it is the more likely candidate for this intermediate form of Building A. In this case, the SA was built before the High MA. It is possible that they could have been built at the same time, as part of a combined stepped platform construction, continuing the stepped platform form of Building A to the south.

The South Face Staircase would have climbed on the SA to the same height as Lower Portada did on the MA.

With the construction of the High SA, therefore, the top of the SA platform was deconstructed, Lower Doble Mensula was deconstructed and modified, Upper Doble Mensula was constructed, and some of the MA vents were blocked.

Columnas-Vigas

Columnas-Vigas likely did not open to the east; no pattern exists of a gallery opening directly to an exterior face when other entrance exists, and in fact, it appears that Laberintos is the only gallery with two proposed entrances. Columnas-Vigas likely extended to an edge aligned with the High NEA, likely continuing to the south with the addition of the High SA. The platform likely extended as high as the base of the free-standing rectangular structures.

Pegs and external alignments

Unusual alignments of external features to internal pegs occurs in Building A. Pegs in Upper Laberintos (Figures 3.74, 3.75) align with the elevation of the tenon head course. Pegs in Cautivos (Figure 3.303) may have had some sort of similar alignment, but exterior face stonework does not exist at this level any more so such a relationship cannot be determined. The Cautivos pegs do sit at the same level as the lintel over the columns in Columnas-Vigas (Figure 3.374), which may have stood in some form here when the Columnas patio was open. The possible significance of these alignments is discussed in Chapter 7.

Tenon head course –relationships externally and internally in Building A

Whether or not the tenon head course continued north from the SA on the west and east faces is an important question. The level of the tenon head course no longer exists on the exterior of the NEA, NWA, most of MA, B, or C; B does not exist at all at this height. On the west side one stone on this layer continues into the MA from the SA. This, along with the presence of fine stonework on the south face of the MA, visible at the Lower Portada entrance, suggests that the tenon head course may have continued on the south face of the MA,

The closest estimate for the level of a tenon head course on the south face of the MA is the stone on the tenon head course on the west face of the MA (Figure 4.45). This level sits at the level of the top course of the portion of the MA south face exposed above the Lower Portada entrance in Lower Doble Mensula gallery (Figure 3.431). The tenon head course is an A course in ABB stonework, and sits at the same elevation as the top course, an A course, visible in the abutment of Lower Doble Mensula to Lower Portada. In other words, the A course at the top of Lower Portada-Lower Doble Mensula abutment is the same course as the tenon-head layer on the

west face. The course appears to slope down slightly from west to east, as it does on the south face of the SA.

The spacing between the eight remaining tenon head locations on the south and west faces ranged between 2.09 m to 2.71 m, averaging 2.43 m apart. The exposed length of the A course at the tenon head level in the MA south face measures only 1.17 m. The normal spacing of the tenon heads thus is wider than the visible space above the door, suggesting that the absence of tenon heads here does not necessarily indicate they did not exist on the south face of MA at this level. If tenon heads existed here, they likely simply spanned the area visible above the Lower Portada doorway.

If the tenon heads did exist on the south face of the MA, it is unclear what their fate would have been with the addition of the SA. They could have been removed intact and possibly reused on the SA. They may have been entombed in the addition. Given the pattern noted by Rowe (1962, 1967) that earlier sculptures were reused, in particular the cornice in the south west corner of the SA, it seems most likely that the tenon heads were removed, perhaps via partial deconstruction of the wall, and reused in the SA.

Although recent studies (Lumbreras 1989; Saffer 1998) have postulated that tenon heads existed all the way around the temple, based on the locations of fallen tenon heads that have been found in the Circular Plaza Atrium as well as the tenon head sockets still in place on the SA, it remains unclear when the tenon heads were first incorporated into the architecture. The tenon head course could have originated in the NWA-High NWA-MA-SA Platform phase, for the following reasons: the spacing of the tenon head sockets and the stonework of the tenon head course appears to continue from the SA in to the MA; the tenon head course sits beneath the level of the MA level, and fine stonework exists on the south face of the MA at this level, as discussed above; and the pegs in Upper Laberintos, which align with the tenon head course, are built in the NWA-High NWA-MA-SA Platform phase as well, suggesting that if the alignment was meaningful that the tenon heads existed by this phase. If so, this suggests that the tenon head

course could have been added to the NEA in this phase with the addition of fine coursework in its upper level.

Architectural alignment variability within Building A

The architectural alignment of some galleries and vents in Building A varies from the architectural alignment of the site by between 1 and 5 degrees west of architectural north. In Murcielagos, the east wall of Segment B is skewed at an angle of 3.59 degrees west of architectural north. The vent trending south from its staircase sits at 2.17 degrees west of architectural north. The east vent in Upper Laberintos sits at 3.38 degrees west of architectural north across its length to Doble Mensula, although it apparently curves, as the north end of the vent is skewed at 1.27 degrees west of architectural north. The middle vent in Upper Laberintos, connecting to Lower Liticos, is skewed at 1.46 degrees west of architectural north. The east wall of the Escalinata entrance sits at 4.42 degrees west of architectural north, while the east wall of Alacenas is skewed 3.98 degrees west of architectural north; these two walls closely align. These alignment variations in Building A occur in its earliest phases, the NEA and the NWA-High NWA-MA-SA Platform. These variations may suggest that in later phases the orientation of galleries became more precise, or that different alignment techniques were used during different construction phases. Future work is needed to further examine the significance of this variability.

Building A Chronology Summary

In summary, the above analyses suggest that the construction sequence for Building A is as follows:

1. The NEA Phase (Figure 4.75-A): The NEA is built to full height, with all its galleries – Escalinata, East Face Gallery, Alacenas, and Zanja. Escalinata and East Face Gallery are centered in the north and east faces respectively. Its faces are built of rough stonework.

2. The NWA-High NWA-MA-SA Platform Phase (Figure 4.76-A): The NWA-High NWA-MA-SA Platform follows as the next phase in Building A. This phase takes the form of large stepped platforms. It contains the galleries Upper Laberintos, Upper Pasos Perdidos, the Marino Gonzalez Staircase, Murcielagos, Lower Liticos, and Lower Portada, largely connected by ventilation shafts. The Lower Portada is a hanging staircase whose doorway is centered in the south face of the MA, and the Murcielagos entrance is centered in the High NWA. Fine stonework exists on the south face, at least in its upper courses as seen at the entrance to Lower Portada. The SA Platform extends to the full length of Building A. The tenon head course may have been introduced in this phase.

The NEA is adapted and integrated into this new phase. The upper northwest corner of the NEA is partially deconstructed to accommodate the east portion of Upper Laberintos and Upper Pasos Perdidos. The MA and the north platform of the NWA are built to the level of the NEA, as indicated in part by the floor level of the High MA galleries. The upper courses of the NEA's east face likely are deconstructed and reconstructed with fine stonework, continuous with the fine stonework on the south face of the MA, creating the CFT in the NEA. The East Face North Staircase is built in this fine stonework, effectively centered in the new combined east face of the NEA and the MA. The coarse stonework of the north face of the NEA remains intact. From a simple, square NEA, Building A has now transitioned to a large, stepped platform mound containing elaborate galleries connected via a system of vents.

3. The High NEA Phase (Figure 4.77-A): The High NEA is constructed, abutting the High NWA and effectively centered along with it atop the NEA-MA. Its construction blocks the south entrance steps to Alacenas, requiring the gallery to be modified and an east entrance to be created.

4. The SA Phase (Figure 4.78-A): The SA is abutted against the south face of the MA. The platform is built up to the level of the MA, the NEA, and the north platform of the NWA. Lower Doble Mensula and Caño are built in this phase. Lower Doble Mensula is placed so that it connects with key vents from galleries to the north, continuing their connection to the exterior. The South Face Staircase replaces the Lower Portada as the centered staircase in the south face, centered more precisely than the Lower Portada doorway. The tenon head course and the cornice level are built here, possibly continuing from the MA.

5. The High MA Phase (Figure 4.79-A): The High MA is constructed above the MA, building on top of the Lower Líticos and Lower Portada galleries and continuing them up through the new vertical addition. It contains Cautivos, Upper Líticos, Upper Portada, South Columnas-Vigas, and the Columnas Patio. Cautivos is built against the south wall of the High NWA, after a course of pegs is added. The Columnas Patio is built south of the High NEA.

6. The High SA Phase (Figure 4.80-A): The High SA is built. Part of the surface of the SA is deconstructed to accommodate Upper Doble Mensula and connect it to Lower Doble Mensula. The High SA blocks numerous vents trending south from the High MA galleries, in a plane aligning with the south seam marked by A-E-2 and A-W-1.

7. The Late Building A Phase (Figure 4.81-A): The Columnas Patio is covered, with walls abutting the High NEA. A seam with red plaster is created, where the addition of North Columnas-Vigas is added to South-Columnas Vigas, filling in the gallery patio. The structural columns are built to help support the ceiling. The free-standing rectangular structures on top of Building A are built, as discussed below.

8. Following this phase, the monumental constructions of Building A were complete (Figure 4.82-A). Support fill constructions were later built up against the base of the west wall of Building A, likely to stabilize it (Rick and Kembel 2000).

Building B

Delimitation

Building B lies between Buildings A and C, and west of the Circular Plaza Atrium (Figures 4.83, 4.84). It contains the Lower Laberintos Gallery, Lower Pasos Perdidos, the Laberintos Alcove, the Lanzón Gallery, and Gallery VIII (see Figures 4.85-A and 4.86-A for below analyses). The ability to carry out internal-external spatial comparisons is limited due to missing upper portions of the exterior walls, buried lower portions of the exterior walls, late structures blocking the exterior walls, and the missing top of the mound, which was swept away by the aluvión of 1945.

Building B Gallery-to-Gallery Analyses

Chronological relationships

Analysis of Lower Laberintos and Outer Lanzón suggests they were built at the same time: their stonework is very similar, their forms are similar, no seams exist between them, they sit at the same elevation, and their stairs ascend to the same elevation where they meet in what is now a small patio. They likely connected via a covered segment located where the patio is today.

The likely construction of Lower Laberintos and Outer Lanzón in the same episode indicates that the structures to which each was abutted both existed prior to the construction of Lower Laberintos and Outer Lanzón. Lower Laberintos was abutted against the entrance to Upper Laberintos, and Outer Lanzón was abutted against the entrance to the Middle Lanzón and its white plaster; this indicates that Upper Laberintos and Middle Lanzón existed at the same time. They both sit at the same level. The fact that Lower Laberintos and Outer Lanzón sit at the same level, at the level of the entrances to Middle Lanzón and Upper Laberintos, suggests that a gallery patio existed between the entrance to Upper Laberintos and the white-plastered entrance to

Middle Lanzón. This patio, here referred to as the Lanzón Patio, would have been filled with the construction of Lower Laberintos and Outer Lanzón. In addition to simply existing at the same time and both opening to the Lanzón Patio, Upper Laberintos and Middle Lanzón appear to have been built at the same time. Their stonework is extremely similar, including large stones and regular chinking, as described in Level 1 analysis. Based on the discussions regarding stonework and chronology in Level 1 analysis, the strong similarities between the stonework in these areas suggest that they likely were built in the same phase.

As discussed in Level 1 analysis, the Middle Lanzón episode was built after the Inner Lanzón Rectangle. The suggested construction of the Middle Lanzón at the same time as Upper Laberintos therefore implies that the Inner Lanzón Rectangle was built before Upper Laberintos as well. This suggests that an early form of Building B, containing the Inner Lanzón Rectangle, was built before the NWA-High NWA-MA-SA Platform phase containing Upper Laberintos.

Forms of Early Building B Phases

If the Inner Lanzón Rectangle was a free-standing rectangular structure, as hypothesized in Level 1 analysis, it likely stood on top of a low platform, here referred to as the B Platform. This B platform would have been the earliest known form of Building B. Whether the Inner Lanzón Rectangle originally stood upon it, or was added later, is unclear.

The fact that the Middle Lanzón sits at a higher level than base of the Inner Lanzón and likely opened to the Lanzón Patio, with which its floor aligns, suggests that by the end of the construction of Middle Lanzón the east side of the B platform had been raised to the level of the Lanzón Patio. If, as hypothesized in Level 1 analysis, the Inner Lanzón Rectangle was roofed in an episode that consisted of both the construction of the Inner Lanzón Chamber and the Middle Lanzón, by the end of that construction Building B would have been a stepped platform, higher on the east where it housed the Inner Lanzón Chamber and the Middle Lanzón, and stepping down to the Lanzón Patio to the east, at the plastered doorway indicated by Lan-E-2.

Relationships of Gallery VIII and the Laberintos Alcove within Building B

Based on a comparison of measurements taken in Gallery VIII by Tello (1960:77, Figure 17, Figure 18, Figure 19, 109) before it was destroyed by the aluvi3n of 1945 to three-dimensional points taken in the Laberintos Alcove and in the Inner Lanz3n Chamber, Gallery VIII and the Laberintos Alcove apparently sat at the same elevation and had a similar height. This suggests they may have been built at the same time. They both likely were built late within Building B. As was shown in the Level 1 analysis, the Laberintos Alcove was built after Upper Laberintos and likely after or at the same time as Lower Laberintos. Gallery VIII lies above the Inner Lanz3n Chamber, and thus must have been built with or after it.

According to measurements by Tello (1960:77, Figure 17, Figure 18, Figure 19, 109) Gallery VIII extended 1.80 m higher than ceiling stones covering the Inner Lanz3n Chamber. Its east vent, 70cm x 70cm, extended 11.90m towards the east face, which would place it in the upper portion of the Circular Plaza Staircase, assuming that the staircase, before it too was destroyed by the aluvi3n, continued higher at the same slope and the vent continued straight and did not curve. Based on the dimensions reported by Tello, Gallery VIII does not appear to have been larger than the Inner Lanz3n Rectangle, as it does not extend across the planes of the outer wall of the rectangular structure below.

Based on its location over the Inner Lanz3n Chamber, Gallery VIII could have been built with or after the Inner Lanz3n Chamber. The chronological relationship between Outer Lanz3n (which is also built after the Inner Lanz3n Chamber) and Gallery VIII is not clear. Possible chronologies include: 1; Gallery VIII was built with the Inner Lanz3n Chamber, and its vent to the east was extended east as new sections were added, and when the staircase was built the vent may have opened through the staircase; 2; Gallery VIII was built after the Inner Lanz3n Chamber, either with the Middle Lanz3n or the Outer Lanz3n-Lower Laberintos construction. If it was built with the Middle Lanz3n, it likely was built with Upper Laberintos, according to relationships

discussed above. If it was built with Outer Lanzón and Lower Laberintos, it could have been built with the Laberintos Alcove, according to relationships established in Level 1 analysis. Gallery VIII and the Laberintos Alcove sit on the same level, in close proximity, and have similar internal heights. This suggests they could have connected, perhaps via the south end of Gallery VIII.

Vertically overlapping segments are rare in the galleries, and where they do exist they usually are built in different episodes. In addition to Lower Laberintos and the Laberintos Alcove, and the Inner Lanzón Chamber and Gallery VIII, Loco and Liticos also contain significant overlapping constructions. Lower Loco was built in a different episode from the rest of the gallery. Lower Liticos was built in a separate episode from Upper Liticos. This pattern suggests that Gallery VIII likely was built in an episode separate from and after the Inner Lanzón Chamber. This issue will be investigated more below, with more evidence on how the area relates to the Circular Plaza Staircase.

Building B Gallery-to-Exterior Analyses

Relationship of Building B Galleries to the upper portion of the Circular Plaza Staircase and the NWA

The relationships of the upper portion of the Circular Plaza Staircase with Outer Lanzón and Lower Laberintos suggest that they were all built at the same time (Figures 4.87, 4.141 – 4.143). The top of the Circular Plaza Staircase has been eroded away and thus its maximum height is unknown. Presently the remains of the stairs sit east of the Outer Lanzón and climb above the level of the entrance to the Lanzón Gallery, to the level just above the top of the Outer Lanzón gallery. The central vent from Outer Lanzón exits underneath and through the stairs. The staircase also overlaps the eastern portion of Lower Laberintos in elevation, and in plan in the east-west direction. The above relationships indicate that the staircase likely was built at the same time as the construction of the Outer Lanzón, Lower Laberintos, and the connection between

them. Additionally, and significantly, the Outer Lanzón episode continues the entrance to the Lanzón Gallery not out the center of Building B, as in the earlier Lanzón episodes, but rather farther to the south. This change suggests that this was done because the Circular Plaza Upper Staircase was built centered within the east face of Building B instead, in the same episode, requiring the entrance to the Lanzón Gallery to be diverted to the south. This links the Circular Plaza Upper Staircase with Outer Lanzón and Lower Laberintos in the same phase.

The upper portion of the Circular Plaza Staircase likely was covered, as indicated by the remains of walls on either side of the steps. This suggests that the east wall of Building B in which it was embedded extended the full north-south length of Building B. This in turn suggests that the present patio in front of Lower Laberintos and Outer Lanzón was covered, likely as a gallery segment, as part of the filling of the east side of the stepped platform formed by Middle Lanzón. Although the present open area here likely is a result of a collapsed wall and ceiling, it is possible that the space between the galleries was a small open patio. The present patio has been largely reconstructed, including the creation of the west wall of the patio above the peg level by Marino Gonzalez (Figure 4.88) (personal communication, 1998; Gonzalez and Rick video interviews, 1995-1998). In either case, the architectural role of the construction of Lower Laberintos and Outer Lanzón is the same: it links the Upper Laberintos Gallery with the Middle Lanzón and the Inner Lanzón Chamber, effectively making them one gallery complex.

The relationships between the Circular Plaza Staircase and the Laberintos Alcove and Gallery VIII suggest that the Laberintos Alcove and Gallery VIII were built with the staircase and thus with Outer Lanzón and Lower Laberintos. The Circular Plaza Staircase climbed at least to the level of the Alcove and Gallery VIII, and the vent of Gallery VIII extended 11.90 m to the east, apparently meeting the stairs, suggesting they were linked.

As described in the Level 1 analysis, the Laberintos Alcove clearly was created after the upper portion of the north external wall of the NWA was broken through. The small portion evident of the NWA north exterior wall is coplanar with the NEA wall and the seam between the

Laberintos Alcove and Upper Laberintos. This means the external wall existed at this location before the Laberintos Alcove was constructed, unlike today where the wall is either missing, buried, or incorporated into other architecture. Whether the exterior wall that the Alcove burst through continued west to the west face is unclear.

The level of the top of Building B above Gallery VIII, based on measurements reported by Tello (1960:Fig 19), aligns with the level of the main platform of Building A formed by the NEA, NWA, MA, and SA. This implies that the final phases of Building B were built to the same height as the platform level of Building A.

These relationships suggest that the final phase of Building B filled the gallery patio between Middle Lanzón and Upper Laberintos on the east face of Building B with Lower Laberintos and Outer Lanzón, and added a layer above the earlier Building B, containing the Laberintos Alcove and Gallery VIII. The Circular Plaza Upper Staircase spanned the elevations of both these areas and likely climbed to the top of the mound, linking the two areas together in one phase. The formerly centered entrance to the Lanzón Gallery was diverted to the south with the construction of the Outer Lanzón, likely to accommodate the simultaneous construction of the Circular Plaza Staircase centered in the east face of Building B.

External Stonework

An important question is whether any seams are evident that separate Building B from Buildings A and C. Much of the exterior walls of Building B are missing, buried, or patched, limiting investigation of the stonework and any seams it might contain (Figures 4.89 - 4.91, 4.40). The little remaining stonework and that revealed in excavations appears to be coarse ABB coursing. 1998 excavations by Rick (Rick et al. 1998) revealed that no seam exists on the west wall at the point aligned with the continuation of the plane of the north wall of Building A. The possible separation of Building B from Buildings A and C is discussed more in the following chapter.

Excavations at Seam A-N-1, Corner of NWA and B

Excavations at seam A-N-1 by Rick (Rick et al 1998:188) revealed the temple walls at the southwest corner of the Circular Plaza Atrium. Results suggested that the walls in this corner were built in one phase. Comparison of the elevations of the walls revealed in this excavation with the internal locations of galleries in the area indicates that Segment E of Upper Laberintos crosses the plane of the NEA north wall and sits directly west of the east wall revealed in this excavation. This indicates that the corner revealed in this excavation is part of the NWA, where the NWA portion of the NWA-High NWA-MA-SA Platform phase extends north of the plane of the north wall of the NEA. This is consistent with the evidence that no seam exists on the west wall at the point aligned with the continuation of the plane of the north wall of Building A, as demonstrated in 1998 excavations by Rick (Rick et al. 1998)

Vents and Pegs in the Inner Lanzón Chamber

The vents to the Inner Lanzón Chamber extend west and east through Building B. The west vent in the Inner Lanzón Chamber connects Segment G directly with the exterior west wall. The east vents extend east through the fill segments of Segments F and H. Measurements down these vents, taken with the laser mapping system, indicate that the vents continue through the fill segments and through the wall of the rectangular structure east of them. Past that point they curve towards the center of the gallery and continue east.

Like the pegs in Upper Laberintos and Cautivos, the pegs in the Inner Lanzón Chamber align with exterior features (Figures 3.189, 3.190). The level of the pegs in the Inner Lanzón Chamber aligns with the coarse-to-fine transition on the east face, south face, and west face of Building A; the floors of Lower Laberintos and Outer Lanzón; and surface of the Lanzón Patio. This level also aligns approximately at the level of the belt of the Lanzón (Figure 4.92), although this alignment might not be original: the force of the mud and stones of the 1945 aluvión

reportedly broke the Lanzón monolith approximately 15cm above its base and shoved the image back against the wall of the chamber (Rowe 1963:43). Additionally, the vertical placement of the pegs varies somewhat, up to 0.19m, although part of this variation could be due to the replacement of some of them by Gonzales (Gonzales and Rick video interviews, 1995-1998). These unusual alignments appear to be more than just an interesting coincidence, and warrant further discussion in Chapter 7.

Building B construction sequence

The spatial relationships within Building B, discussed above, suggest the following construction phases:

1. The B Platform-ILR Phase (Figure 4.93-A): A low platform is constructed, here called the B Platform. The Inner Lanzón Rectangle (ILR) is constructed above the west portion of the platform.

2. The WB-MB Phase (Figure 4.94-A): The Inner Lanzón Chamber episode is constructed by building support blocks in the corners of the Inner Lanzón Rectangle and roofing the resulting cruciform with stone ceiling beams. East of the Inner Lanzón Rectangle, in the Middle Building B area, the Middle Lanzón episode is constructed. I hypothesize that these two gallery construction episodes may have been part of the same construction phase, in which the Inner Lanzón Rectangle was converted from a free-standing rectangular structure to a gallery. In this hypothesis, Middle Lanzón and Middle Building B (MB) are built to extend the entrance to the Inner Lanzón Chamber up and to the east, to a gallery patio. The area west of this, West Building B (WB), fills in the area between the Inner Lanzón Rectangle and the new west wall of Building B at the level of the rectangle. This appears to be the most likely scenario; however, it is possible that the Inner Lanzón Chamber, the WB, and the MB containing the Middle Lanzón could have been distinct phases within this overall pattern.

As discussed in Level 1 analysis, the Lanzón monolith likely is in place by the end of the construction of the Inner Lanzón Chamber, because the chamber's form suggests it was built specifically to house the Lanzón monolith. Whether the Lanzón monolith was in place within the Inner Lanzón Rectangle is unclear, but I hypothesize that the tall, narrow, free-standing form of the monolith itself suggests that perhaps the Inner Lanzón Chamber and the Lanzón monolith were designed together: the monolith may have been designed to fit the space as much as the space was designed to house the monolith.

The MB area likely is built simultaneously with Upper Laberintos and the rest of the NWA-High NWA-MA-SA Platform phase of Building A. The entrances of Upper Laberintos and Middle Lanzón are connected by a gallery patio on top of the B Platform. The above hypothesis linking the MB and the WB as one phase therefore implies that the WB area and the Inner Lanzón Chamber were also built with the NWA-High NWA-MA-SA Platform phase of Building A.

3. The EB-High B Phase (Figure 4.95-A): East Building B (EB) and High Building B (High B) are built together in the EB-High B Phase. Outer Lanzón, Lower Laberintos, and the area connecting them are built directly upon the surface of the Lanzón Patio, abutting to Middle Lanzón and Upper Laberintos, in EB. Laberintos Alcove and Gallery VIII are built in High B, with Gallery VIII located directly above the Inner Lanzón Chamber. The upper portion of the Circular Plaza Staircase is built as a covered staircase in the center of the east face of B, spanning the elevations of both EB and High B. Its placement in the center of the east face of Building B likely causes the entrance to Outer Lanzón to be built to the south, rather than opening in the center of Building B as the Middle Lanzón and Inner Lanzón Rectangle did.

The overall sequence that emerges regarding the construction of Building B (Figure 4.96-A) begins with a low platform topped by a free-standing rectangular structure. This rectangular structure and low platform are converted into a stepped platform that opens to a gallery patio to

the east. The stepped platform is then filled to the east, and the building is raised, with a centered staircase ascending from the east.

Given the small amount of external stonework visible in Building B, hypotheses for excavations to reveal possible seams between it and Buildings A and C were developed, as seen in the next chapter. Future work is required to continue to reveal stonework and investigate the presence of seams in the west and east walls of the temple.

Building C

The construction history of Building C is not clear. A number of different elements that may contribute to understanding its history are evident, however (Figure 4.97-A, Figures 4.98 - 4.99). Among these are the four episodes of construction of the known galleries in the mound, Loco and Mirador. They include a clear horizontal seam between Lower Loco and the rest of the gallery, indicating that a horizontal addition was made at least to the west end of the mound. Above the level of this seam sits the Rooms episode of Loco, which consists of five small free-standing rectangular structures that likely stood open on the mound. These rooms were later connected by the South Loco Episode. To this was later added North Loco and Mirador, with a shift in the architectural axis of the gallery and the likely construction of an open Loco Patio north of the gallery entrance or entrances, as noted by Tello (1960:Figure 9, 110-111) prior to the 1945 aluvión.

Building C Gallery-to-Gallery Relationships

There appears to be no clear link between these galleries and the galleries of other buildings in terms of alignments. The elevations, while similar, do not suggest chronological relationships. The top of Lower Loco aligns with the top of the Inner Lanzón Chamber, and Upper Loco does sit at a similar elevation to Murcielagos. The remains of the top of the mound

suggest Building C likely was at least as tall as the High NWA, particularly given reports that this mound was particularly hard hit by the 1945 aluvión, which wiped away a modern chapel that had been built atop the mound (Tello 1960). The vertical seams marking the Rooms in the west part of the gallery are located similarly to those in Segment E of the Lanzón Gallery, but do not exactly align. More importantly, the construction chronology of the seams are different between Loco and Lanzón; in Loco, for example, the east side of a seam was built before the west side, whereas in Lanzón, at a seam that is in a similar east-west location, the west side was built before the east side. This indicates they do not share the same seams. Additionally, the galleries are located on different levels; if they shared seams, the seams would have had to have spanned two levels, which is possible but would make the construction history more complex.

Building C Gallery-to-Exterior Relationships

External Stonework

The stonework on the south wall of Building C, forming the north wall of the Circular Plaza Atrium, also provides some insight into the construction history of the mound (Figure C Details, Figures 4.100 - 4.110). The stonework visible in the base of the wall follows an ABB pattern. A protruding layer of stones, similar to a cornice course, forms the highest B layer of this pattern. It is topped by an A layer. Above this course, the coursing transitions, continuing up the wall in a B pattern. While it clearly has undergone some reworking, and is poorly preserved in some areas, the B stonework appears to be fine, worked stone, in contrast to the coarse ABB courses below. This pattern suggests that the transition between coarse ABB coursing and fine B coursing here may separate this area of Building C into two phases, the first consisting of the ABB course stonework topped by the cornice-like course and an A course above it, the second built of B courses primarily of more finely worked stones. Alternatively, this could merely

indicate an exterior coursework change instead, such as a coarse-to-fine transition similar to that in Building A. This transition on Building C is higher in elevation than the CFT of Building A.

The cornice-like course is located west of the Loco and Mirador galleries. A direct association between the cornice-like course and the galleries therefore is not clear, but the cornice-course sits approximately 0.30 m below the current floor of Lower Loco, which approximately aligns with the transition between the ABB and B coursework above the cornice-like course. This suggests a possible link may exist here indicating a horizontal seam at the level of the transition between coursework types. Clearer evidence must await further excavation of the post-Chavín remains of the Circular Plaza Atrium away from the south wall of Building C, revealing more of the stonework here.

External seams

No external seams have been identified for Building C, in large part because most of its south wall is buried by the late accumulated remains in the Circular Plaza Atrium, and because the stonework of its east, north, and west walls is either missing or buried (Figures 4.111 - 4.122, 4.89). One hypothetical vertical seam may lie in the middle of the building, at the northwest corner of the Circular Plaza Atrium, at a plane aligned with A-N-1. This plane aligns just east of the east wall of Loco, suggesting that perhaps Loco could have been built up against the wall of an earlier mound here, a possible counterpart to the NEA. In this case, the west part of the mound, containing Loco, could have been built after this counterpart to the NEA, perhaps as a counterpart to the NWA. It would connect Building B to Building C, just as the NWA connects Building A to Building B. The extension of the Mirador Gallery east across this plane suggests the east mound may have stepped down to the north, and that Mirador was later built across the plane. Based on these alignments, an excavation pit was placed along the north wall of Building C along this plane in the 2000 field season by Rick, to determine whether or not such a seam does exist in the north wall of C, in plane with A-N-1. Late, possibly colonial-period, structures blocked the wall

here, obscuring the view of the original wall. Determining whether or not a seam does lie along this plane must await larger-scale excavation to remove these late structures, or the excavation of the south wall of the Building C in the Circular Plaza Atrium.

Megalithic support wall

A megalithic wall exists along the west face of Building C at its north west corner. Excavations by Rick in 1998 confirmed that this is a wall supporting the west wall of Building C. The present top of this wall sits at the elevation of the top of Lower Loco and the floor of north Loco. This suggests it was built after Lower Loco was constructed. However, the original top of the support wall and the top of Building C clearly have eroded away, suggesting they both originally climbed even higher. If the support wall did climb higher, it would have climbed into the elevation of Upper Loco, suggesting it was constructed after Upper Loco was complete. This suggests that it likely was the last phase of construction of Building C.

Building C Construction Sequence

The order of construction that can be determined for Building C with the available evidence, therefore, is the following:

1. Low Building C is constructed containing Lower Loco. The free-standing rectangular structures of the Rooms episode of Upper Loco sit on top of the mound.
2. High Building C is built, incorporating the structures of the Rooms episode and containing the remaining two episodes of Upper Loco – South Loco, North Loco and Mirador.
3. The support construction is built, likely to stabilize the west wall.

With clearing of the exterior walls of Building C, as discussed above, refinement of this construction history of this building is highly likely.

Circular Plaza Atrium

The Circular Plaza Atrium consists of the area between the north wall of the NEA and the south wall of Building C, bounded by the east wall of Building B (Figures 4.83, 4.84, 4.123, 4.124). It includes the Circular Plaza, the Circular Plaza Terrace, the lower portion of the Circular Plaza Staircase, and the Ofrendas, Campamento, and Caracolas Galleries (see Figure 4.125-A).

Gallery-to-Gallery Relationships within the Circular Plaza Atrium

The Ofrendas, Campamento, and Caracolas Galleries sit on the same level, and their ceilings lie at the same elevation. The floor level of Ofrendas is the lowest and most likely the closest to the original depth, because it has been excavated (Lumbreras and Amat 1965-1966; Lumbreras 1993). The floors of the other two galleries sit slightly higher than this level due to fill, as neither gallery has been fully excavated and the original floors of both are buried. Because their ceilings lie at the same level as the ceiling of Ofrendas, they both likely had the same floor levels as Ofrendas.

In plan view, the architectural alignment of Ofrendas differs from those of Campamento and Caracolas. While Caracolas is aligned to architectural east-west, and Campamento is closely aligned to architectural east-west but with a slight northwest-southeast rotation of its east-west axis, Ofrendas gallery has a distinctive northwest-southeast architectural alignment. The axes of both Caracolas and Ofrendas are parallel with the temple walls to which they are closest, Caracolas to the north wall of the NEA and Ofrendas to the south wall of Building C. This implies that the north wall of the NEA existed before Caracolas was built, and that the south wall of Building C existed before Ofrendas was built.

Both Campamento and Caracolas clearly extended farther than they do presently, as evidenced by collapse and blocked passageways in them and the lack of an identified doorway in both. It is possible that they may have connected at some point with each other and/or with other

as yet unidentified galleries that may have existed in the Circular Plaza Terrace. A vent trending west from Caracolas vent extends west 3.49 m before it terminates, suggesting that perhaps an open space or another gallery exists west of Caracolas.

Gallery-to-exterior relationships within the Circular Plaza Atrium

Campamento, Caracolas, and Ofrendas sit at the same elevation as the Circular Plaza. Their galleries' ceilings sit at the same level as the highest extent of the plaza walls. The floors of the galleries sit just above the elevation of the base of the circular plaza walls: the Ofrendas floor sits approximately 0.12 m above the elevation of the base of the walls of the circular plaza. This alignment and their integrated construction within the Circular Plaza Terrace suggest that the Circular Plaza, its galleries, and its terrace were built in one phase, here named the Circular Plaza Atrium phase. This conclusion was reached as well by the excavator of the area (Lumbreras 1977, 1993).

The base of the Circular Plaza Atrium phase aligns with the elevation of the foundation of the NEA, as defined by the base of A-E-1 marking the southeast corner of the NEA. The Circular Plaza Terrace was constructed on top of this level. This, and the construction of the galleries within the terrace, indicates that the Circular Plaza is not really “sunken” – rather, the platform around it has been elevated.

Campamento currently extends east of the east walls of the NEA and Building C. Its collapsed segments suggest that it continued even farther to the east.

The relationship of Ofrendas with Building C could potentially shed some light on the their construction. The vents from Ofrendas extend north, suggesting that either an open space exists between the gallery and the south wall of Building C, or that the vents connect with vents from another gallery at the base of Building C. The vents extend approximately 4.20 m before

terminating; this distance approximately aligns with the south wall of Building C, accounting for batter.

Relationship between the Circular Plaza Terrace and Escalinata

The relationship between the Circular Plaza Terrace and the entrance to Escalinata is particularly important to understanding the chronology of this area. The Circular Plaza Terrace blocks the entrance to Escalinata (Figure 4.126-A, Figure 4.127). The estimated height of the Escalinata entrance, based on Level 1 analyses, is 3.2 m; it extended down to the level of the NEA foundation, on top of which the Circular Plaza Terrace phase was built. The bottom of the north doorway lintel in Escalinata measures 0.64 m to the present level of fill over the entrance floor, and 1.01 m to the ceiling of Caracolas, with 0.37 m between the current fill level in the entrance to Escalinata to the level of the Caracolas ceiling. These measurements do not include the thickness of the ceiling of Alacenas and the terrace surface above it, as these are not presently evident. The construction of the Circular Plaza Terrace in front of the Escalinata doorway, blocking the entrance to the gallery, indicates that the Circular Plaza Terrace was built in a separate phase after the Escalinata Gallery and the NEA. Consistent with this conclusion is the fact that the Circular Plaza is not centered with respect to the Escalinata entrance, as well as the fact that the Circular Plaza is oriented east-west, rather than north-south like the Escalinata entrance.

Until the construction of the Circular Plaza Staircase or any precursors, Escalinata apparently served as the primary direct connection between ground level and the top of the temple buildings. Besides Escalinata, the Circular Plaza Staircase is the only currently known staircase that clearly extended to the ground. It is possible that the Circular Plaza Staircase and the EB phase were built over a staircase from an earlier phase. After Escalinata was blocked by the Circular Plaza Terrace, the Circular Plaza Staircase may have been the only entrance into the

temple. With the construction of the Circular Plaza Staircase descending to the east and replacing the Escalinata staircase descending to the north, the orientation of the temple completed the shift from north to east.

Circular Plaza Staircase – chronological relationships

Evidence suggests that the Circular Plaza Staircase (Figures 4.128 - 4.130) was built in one episode (Figure 4.131-A). The staircase contains two areas: an upper, narrow staircase within Building B, and a lower, wider set of steps east of Building B, between the east face of Building B and the Circular Plaza. A stepped, stone-lined canal whose base is constructed with small, fine overlapping stone slabs lies immediately underneath the center of the steps and descends the full length of the staircase (Lumbreras 1974:45). The canal is fully integrated into the construction of the staircase, serving to drain the mound possibly with a ritual-acoustical function (Lumbreras et al. 1976). The integrated construction of the canal and the staircase from top to bottom suggests the staircase was built in one phase. Additionally, the transition between wide and narrow stairs corresponds with the transition from external to internal steps. The remains of walls on both sides of the upper portion indicate it likely originally was a covered interior staircase. This means its maximum width would have been constrained, and that it likely was built without mensulas, given the architectural patterns noted in Level 1 analysis. The upper staircase is centered within the east face of Building B, similar to other internal staircases, measuring 20.83 m to the north and 20.21 m to the south. In contrast, the lower steps east of Building B were not internal, and thus could be wider than the internal steps. The integrated construction of the canal and the staircase suggest they were built simultaneously, while the transition between wide and narrow stairs corresponds with the transition from external to internal steps between the upper and lower portions of the staircase, and is consistent with the construction of the staircase in one episode. The likely construction of the Circular Plaza Staircase in one episode does not preclude the

possibility that an earlier staircase could have existed in this area during earlier phases of Building B.

The conclusion that the Circular Plaza Staircase was built in one phase suggests that the Circular Plaza links the last phase of Building B, the EB-High B Phase, with the Circular Plaza Terrace and its galleries, as one chronological unit. Analysis of Building B above indicated that the upper, internal portion of the staircase was constructed in the EB-High B Phase of Building B. The base of the staircase is fully integrated with the west portion of the Circular Plaza itself, and the staircase climbs from the base of the Circular Plaza into Building B up to the level of Gallery VIII above the Lanzón Gallery, connecting the two areas. This suggests that the Circular Plaza Staircase was built simultaneously with the EB-High B Phase as well as the Circular Plaza Terrace and its galleries.

After it is complete, evidence suggests that the Circular Plaza Atrium undergoes a period of support constructions (Lumbreras (1977:10; 1993:Figure 3). Walls are built against the lower part of the east face of Building B near the Circular Plaza Staircase and against the north and south sides of the staircase where it emerges from Building B into the Atrium. These walls are associated with Level H, the level immediately above the floor of the Circular Plaza and above the Circular Plaza Terrace (Lumbreras (1977:10; 1993:Figure 3).

Summary of Circular Plaza Atrium Construction

Analysis suggests that the Circular Plaza Terrace, the Circular Plaza, the Circular Plaza Staircase, the Ofrendas Gallery, the Campamento Gallery, the Caracolas Gallery, and the network of drains and spaces within the terrace were built in one phase, grouped as the Circular Plaza Atrium phase. One of the most important implications of this analysis is that the Circular Plaza Atrium phase was built later than the NEA and likely later than Buildings B and C, blocking the entrance to Escalinata and filling in the area between the walls of the Atrium. The base of the

Circular Plaza Atrium phase appears to sit at the elevation of the foundation of the NEA.

Evidence suggests that the Circular Plaza Staircase was built in one phase, with both the Circular Plaza Atrium and the EB-High B phase of Building B, suggesting that the Circular Plaza Atrium phase and the EB-High B phase likely were built together, in an EB-High B-CPA phase. Walls built against the east face of Building B and the sides of the Circular Plaza Staircase where it meets Building B suggest this area later underwent a period of support constructions.

Building D

Building D is quite deteriorated and little of its exterior walls remain or are exposed. The two known galleries sit at different elevations and do not sit at 90 degrees to each other, but provide little information on the construction history of Building D.

Building E

Building E (Figure 4.132) lies south of the Plaza Mayor (see Figure_9002). Its east edge has been extensively eroded by incursions of the Rio Mosna earlier this century, as Tello witnessed first-hand (Tello 1960). The erosion exposed a cross section of the mound, including one of the galleries as well as ceramics and other artifacts near the mound's base. Presently the mound contains two known galleries, the Escondida Gallery on the west end, of which only a small portion has been cleared, and the Cortada Gallery, which was cut by the river and is in poor condition, threatening collapse (Figure 4.133). When Tello visited the site in 1919, the gallery was 50m long; in 1934, after much river erosion, only 24 m of the gallery remained (Tello 1960:86). Gaps in the stonework on the top of Building E suggests that gallery lintels lie just beneath the surface, indicating that more galleries or gallery segments likely were present than the two known presently. One of these voids was a stone-lined vertical shaft. The mound

currently contains two staircases on its north face that descend to ground level; given that these staircases are symmetrical to the western two on Building F, it is likely that the east extent of Building E, now eroded, contained a third staircase symmetrical to the eastern staircase on Building F. Much of the Building E is obscured, particularly to the south where platforms are covered by aluvi3n and overgrowth, covering what appear to be possible seams.

Building E Gallery-to-Gallery Relationships

The Escondida Gallery lies within the southwest corner of the building. The Cortada Gallery sits near the present northeast corner. The ceiling of the Escondida Gallery sits approximately 1.28 m above the ceiling of the Cortada Gallery. The two galleries do not overlap in either east-west or north-south directions.

External Evidence of Construction

Exterior evidence suggests that an earlier building existed here and was followed by an addition to the north and top of the mound. Seams exist on the west face of the mound, in the inset northwest corner. The south portion runs underneath and behind the north portion (Figures 4.134 - 4.137). A vertical seam exists in the corner, in which the north portion abuts the south portion. The courses on the two sides of the seam do not align. Above the top course of the south portion lies a horizontal seam marking where the north portion has been abutted up over the south portion. This indicates that the portion to the south, which extends farther to the west, must have been built before the portion to the north, which climbs over the south portion. This suggests that the whole north face, including the staircases on the north face and the added height, was built onto an older, smaller building.

A course of cornice-like stones sits at the current top of the north wall of the older phase, on the west end of the building, overhanging a course comprised of unusual round stones (see 4.136, 4.134 above). The cornice-like course and the round stones appear to be a decorative feature. They are similar to the cornice and tenon head arrangement on the west face of Building A, and may be a variation on or possibly an antecedent to these architectural features (Jean-Pierre Protzen, personal communication, 1997).

Building E Gallery-to-Exterior Relationships

The Escondida Gallery sits south of the vertical seam in the inset northwest corner of the mound and beneath the level of the horizontal seam (Figures 4.138- 4.139). This indicates that the Escondida Gallery likely was constructed in the early building described above. The Cortada Gallery lies north of the vertical seam and beneath the east staircase on the north face, indicating that the Cortada Gallery likely was built in the addition to the early building.

At the east end of the north wall of Building E , megalithic courses sit above courses of small stonework (Tello 1960: 86, 87, Lam. XVIII A, Lam. XIX A). The transition between them, marked by the lower boundary of the megalithic stones, lies at the level of the dirt surface covering the floor of the Cortada Gallery. A vent in the east end of the megalithic wall lies at the level of the Cortada Gallery, 6.65 m east of the present east edge of the gallery but within the east extent of the gallery length recorded by Tello (1960) prior to the deepest incursions of the river. The alignment of the vent at this level suggests that the vent and the gallery were built in the same phase, consistent with the evidence, above, that Cortada was built with the north face addition. A drainage canal that trends east-west, parallel to and north of the gallery, sits below this transition level. The transition between small and megalithic courses also lies at the level of the Plaza Mayor Terrace and the top of the walls of the Plaza Mayor (Figure 4.140). The vertical seam in the Cortada interior is not apparent in the north face exterior of the mound.

Further research clearly is required to investigate the construction history of this building. For example, it is unclear whether the megalithic courses were built atop an earlier structure of small stonework, or whether the megalithic and small coursework were part of the same construction episode. Tello (1960:86, 87, Lam. XVIIIA, Lam. XIXA) concludes that the wall of small courses was an earlier construction. Additionally, Tello's profile (Tello 1960:Figure 8) of the building interior, as revealed by the river cut, suggests that the construction history of this mound was complex. Different types of fill and wall constructions cut through the mound, including a megalithic wall with an overhanging north ledge (Tello 1960:85, Figure 8), perhaps representing a continuation of the wall on the north side of the early building described above. An understanding of this building's construction complexities, visible in this cross-section, may identify other phases as well as provide insight into construction processes not evident in other buildings.

Summary of Construction History of Building E

Based on the available evidence, presented above, Building E appears to have been built in two phases. The first phase consisted of a low building constructed partly of megalithic stones and containing the Escondida Gallery. Walls of this building are visible in the southwest corner of the mound, extending farther west than the rest of the building. The second phase was added to the north face and top of the early building. It was constructed of megalithic stones, likely with three staircases on its north face. The Cortada Gallery was built during this phase in the northwest end of the building, running underneath the present east staircase. Future investigation into the apparent complex history of this mound likely will reveal more construction phases.

Summary - Levels 2-3 Analyses

Investigating the spatial relationships between galleries, and between the galleries and the external architecture, and enables construction phases to be isolated and sequenced. The above analyses identify eight phases in Building A, three phases in Building B, three phases in Building C, one phase in the Circular Plaza Atrium that is linked with the last phase of Building B and followed by a second phase of support constructions, and two phases in Building E. The specific forms and components of these phases are described and summarized above, and are summarized in Chapter 6.

The above Levels 2-3 analyses also help identify construction principles, in addition to those identified in Level 1 analyses. These new patterns include:

- The external architecture and the galleries are highly integrated.
- Construction phases are modified, adapted, and added to frequently.
- Galleries span multiple levels.
- The locations and forms of many galleries are determined by the need to continue vents from older structures through new ones to the exterior.
- Vent placements in relation to seams forms an important source of information regarding construction phases.
- Some internal staircases are extended higher in later additions.
- Gallery pegs align with external features.
- Staircases are centered.
- Horizontal seams marking vertical additions are not easily identified. They are not necessarily marked by changes in exterior coursing, nor do changes in exterior coursing necessarily mark a horizontal seam. Horizontal features other than seams may be highlighted. A vertical seam intersecting the seam and/or the correspondence of internal features with the horizontal seam help in its identification.

The results of Levels 2-3 analyses provide the foundation for carrying out site-wide analyses of construction phases and patterns, as presented in the following chapter. They also enable issues regarding site use to be examined, as seen in Chapter 7.

CHAPTER 5

LEVEL 4 ANALYSIS: SITE-WIDE SPATIAL AND CHRONOLOGICAL RELATIONSHIPS

Whereas analyses in the previous chapter addressed the spatial relationships and construction sequence within Buildings A, B, and C and the Circular Plaza Atrium, the scope of analysis widens in this chapter, addressing architectural relationships and principles at more of a site-wide level. The below discussion first addresses staircases in Buildings A, B, and C as a group, examining their prominent role and aspects of construction principles related to them. Focus then shifts to the area of the site east of Buildings A, B, and C and the Circular Plaza Atrium, analyzing the architectural sequence of this area and how it relates to the sequence of Building A. This is followed by a discussion of the construction sequences of Buildings B and C in relation to Building A.

Staircases in Buildings A, B, and C

Three types of staircases exist in Buildings A, B, and C: staircases within galleries, staircases that connect ground level with the top of buildings, and staircases that descend from the top of buildings and open to the exterior faces well above ground level, referred to as hanging staircases. These staircases are a central element of Chavín construction patterns, and help decipher the chronological relationships between areas.

Patterns that have emerged from examinations of internal staircases in the previous two chapters include: galleries usually are entered via descending staircases; staircases connecting galleries on different levels indicate the galleries were built at different times; and some staircases are extended higher in additions, such as in Upper Liticos and Upper Portada. The Lower Portada

Gallery is of particular interest here, because its “categorization” within the above three types of staircases has switched over time. It began as a hanging staircase on the south face of the MA. With the addition of the SA and the Lower Doble Mensula Gallery within it, the Lower Portada Gallery switched from a hanging staircase to a staircase leading down to a gallery.

The hanging staircases in Buildings A, B, and C include the Lower Portada Gallery, the East Face Gallery, the Marino Gonzalez Staircase, the East Face North Staircase, the East Face South Staircase, and the South Face Staircase. The bases of the East Face North and South Staircases apparently sat at the same levels, one course below the CFT, although all but the north edge of the north staircase is missing or buried. The base of the South Face Staircase sits 1.24m above that of the Portada Staircase. The base of the East Face Gallery sits at the same level as the estimated base of the Marino Gonzalez Staircase.

Escalinata and the Circular Plaza Staircase are the two known staircases in Buildings A, B, and C that descend to ground level. It is possible that, prior to its final construction phase, Building B contained other staircases that preceded the present Circular Plaza Staircase.

Covered Staircases

The hanging staircases in Building A appear to have been covered originally, not open and uncovered as some are today. This reasoning is based in large part on the fact that the hanging staircases that are still largely intact are covered: the Lower Portada Gallery, the East Face Gallery, and the Marino Gonzalez Staircase. Additionally, hanging staircases that currently are uncovered are in this state primarily because they have been partially or largely destroyed; the East Face North Staircase, the East Face South Staircase, and the South Face Staircase are currently uncovered likely because the exterior stonework above them no longer exists, not because they originally were uncovered. The east and south faces of Building A clearly extended higher than they do today, as indicated by the remains of their exterior stonework and the height

of the temple above them. Wall remains in these three staircases, particularly those on the east face, suggest that they originally supported ceiling beams spanning the stairs. This evidence and the fact that the presently intact hanging staircases are covered, suggests that as a rule hanging staircases originally were covered.

Evidence suggests that the staircases that descend to ground level, Escalinata and the upper portion of the Circular Plaza Staircase, in Building B, also were covered. As shown in Level 1 analysis, Escalinata appears to have been covered by large ceiling lintels, some of which are still in place. The remains of walls on either side of the upper portion of the Circular Plaza Staircase indicate that it too, like the hanging staircases, likely was covered originally. The lower Circular Plaza Staircase does not sit within Building B, but rather lies in the Circular Plaza Atrium; like its counterpart on the east side of the Circular Plaza, it stood open, climbing up to the east face of Building B.

Symmetrical Staircases and Construction

Staircases that connect to the external faces of Buildings A and B were built according to a pattern of bilateral symmetry. In early phases, staircases were centered within their external face. As later additions were built, existing architecture was adapted to maintain staircase centeredness within the new exterior faces resulting from combined new and old phases. Towards the end of the sequence simple centeredness no longer was possible in some cases due to constraints imposed by earlier phases, so the pattern expanded to include pairs of staircases bilateral symmetrical around a central point in these cases. (See Tables 5.1 and 5.2 for measurements regarding centered staircases and doorways.)

The measurements in Tables 5.1 and 5.2 indicate that the East Face Gallery and Escalinata were centered in the east and north faces of the NEA, respectively. The Lower Portada was centered in the south face of the MA, and the South Face Staircase was centered in the south

face of the SA; note that the South Face Staircase, which effectively replaced the Lower Portada staircase when it was covered with the addition of the SA, is more precisely centered than the Lower Portada was (0.03 m compared to 0.50 m), suggesting an increase in precision in centeredness between these two phases. The upper portion of the Circular Plaza Staircase is centered in the east face of Building B. Additionally, the entrance to Murcielagos, leading to a staircase that descends into the gallery, is centered in the south face of the High NWA, whose east-west length is bounded by the west face of the temple and the plane of the A-N-1 seam.

Measurements with respect to the East Face North Staircase reveal how earlier phases were adapted when new ones were added, while measurements regarding the East Face South Staircase demonstrate how new additions were incorporated by switching from single centered staircases to pairs of bilaterally symmetrical staircases (see Tables 5.1 and 5.2). The East Face North Staircase is built within the east face of the NEA, but it not centered within the east face of the NEA; rather it is centered within the east face of the combined NEA-MA. The East Face South Staircase is built within the east face of the SA, but it is not centered within the SA. In fact, it is not centered within any combination of phases on the east face. Rather, it is symmetrical with respect to two other staircases. First, it and the East Face Gallery are symmetrical about the central point of the full east face of Building A. Second, it and the East Face North Staircase are symmetrical not about the center of Building A, but about the center of the Black and White Portal, here referred to as the Black and White Axis and discussed further below.

Whether a hanging staircase centered in the east face of Building A, in the MA, also existed is unclear, because this MA portion of the east face is largely missing, leaving little evidence of what existed above. If it had, it would have formed a central staircase around which the others were symmetrical. If not, the others would simply have been symmetrical pairs. Whether such a staircase would have been centered with respect to the east face of Building A, centered between the East Face Gallery and the East Face South Staircase, or instead with respect to the Black and White axis, centered between the East Face North Staircase and the East Face

South Staircase, is a question left to speculation. Both would have required deconstructing the MA to accommodate such a staircase with or after the addition of the SA.

How the Marino Gonzalez Staircase may have fit within the pattern of staircase symmetry is unclear, because the north extent of the phases in which it would have been centered has not been identified, nor has another staircase with which it might be symmetrical. The Marino Gonzalez Staircase is not centered in the full west face of the temple. If it followed the symmetry pattern of staircases, it would be symmetrical within the combined west face of the NWA-MA (in which it was constructed) and any phases to the north to which the NWA was abutted. It is also possible that the Marino Gonzalez Staircase is an exception to the pattern of symmetry. Reasons for such an exception may include: a constraint imposed by the proximity of the Marino Gonzalez Staircase to possible earlier phases that could not be adapted to new constructions, such as perhaps the Inner Lanzón Chamber in Building B; a functional constraint in which the Marino Gonzalez Staircase was needed to climb to the top of the NWA rather than to the top of the High NWA, higher and farther south in the NWA-MA west face; an alignment between the Marino Gonzalez Staircase and possible unknown structures currently buried in the West Field; or possibly a loosening of the symmetry pattern on the west face, perhaps due to less focus on the west face than on the east.

The staircase symmetry pattern was used to investigate the west face of Buildings A, B, and C, based on the idea that perhaps this pattern could be used here to help predict possible seam locations. These rules were used to frame hypotheses regarding the construction history of the west wall. This involved working with the Marino Gonzalez Staircase as if it followed the centered or bilateral symmetry pattern, to help hypothesize where seams might sit along the west wall of Buildings B and C. Results strategic of excavations based in part on these predictions are presented below.

Symmetrical staircases exist in many phases of construction in Buildings A and B. The East Face Gallery and the Escalinata Staircase were built at the same time, in the NEA phase. The

East Face North Staircase, the Lower Portada Staircase, the Marino Gonzalez Staircase, and the Murcielagos stairs were built together in the NWA-High NWA-MA-SA Platform phase. The East Face South Staircase and the South Face Staircase were built at the same time, in the SA phase. The Circular Plaza Staircase was built in the EB-Circular Plaza Atrium Phase.

In sum, the above evidence indicates that staircase symmetry in Buildings A and B was an important building pattern across a large span of building phases. This pattern was important enough to warrant deconstructing parts of earlier phases and adapting them to the addition of new ones. It was also flexible enough to be expanded in later phases to include pairs of bilaterally symmetrical staircases in addition to centered staircases, in order to adapt new additions to constraints imposed by earlier phases.

Construction Sequence of the East Area

The East Area consists of the buildings, terraces, and platforms east of Building A, Building B, Building C, and the Circular Plaza. This includes the Plaza Menor Terrace and its structures such as the Black and White Portal, the zócalo of the Black and White Portal, the Plaza Menor, and the Black and White Staircase; the Plaza Mayor and its surrounding Plaza Mayor Terrace; the Middendorf Staircase; Building F; Building G; Building E ; and Building D (see Figure 1.3-A, Figure 5.1).

A subset of these structures were built relative to an axis marked by the central dividing line of the Black and White Portal and a reference marker on the first step of the east staircase of the Plaza Mayor (Rick et al. 1998). Referred to as the axis of the New Temple by Rick et al. (1998), this axis is here referred to as the Black and White Axis, for reasons that become clear in later analyses. These structures are directly aligned with or bilaterally symmetrical to the axis, with a high level of precision (Rick et al. 1998).

An analysis of abutment relationships between the structures of the East Area as well as the relationships of structures to the Black and White axis enables the construction sequence of the area to be studied, as presented below.

The Plaza Menor Terrace

The Plaza Menor Terrace (called Segunda Terraza in Rick et al. 1998) lies west of the Plaza Mayor and forms the primary elevation change between Building A and the Plaza Mayor Terrace (Figure 5.2). Its top surface forms the ground level beneath the east face of Building A, and contains the Black and White Portal and surrounding structures as well as the Plaza Menor. A large megalithic wall marks its east edge, over which the Black and White Staircase climbs to connect the Plaza Mayor Terrace with the top of the Plaza Menor Terrace. In the south portion of this wall a large doorway exists (Figure 5.3). It leads to a long passageway and possible former gallery that trends west, south of Building A, until it terminates in uncleared aluvi3n. The Plaza Menor Terrace contains a network of horizontal and vertical stone-lined drains and canals.

The megalithic wall of the Plaza Menor Terrace currently is visible south of the Black and White Staircase (Figure 5.4 - 5.8). North of the salient of the Black and White Staircase, the megalithic stonework is fronted by a wall of smaller, more irregular coursework (Figure 5.9 - 5.13). The megalithic wall can be seen behind this wall in the corner immediately north of the Black and White Staircase; some of the smaller stonework has fallen away, revealing the megalithic courses behind (Figure 5.14 - 5.16). This wall of smaller stonework was clearly added after the construction of the megalithic wall, likely as a stabilizing support wall. Other smaller, later walls have been added around this area and the base of the Black and White Staircase and its salient as well.

North of the Black and White Staircase, the wall of the Plaza Menor Terrace measures 12.55 degrees, while south of the Black and White Staircase, the wall of the Plaza Menor Terrace measures 13.65 degrees (Rick et al. 1998:201, Figure 15). This difference likely is due to the

addition of the support wall in front of the original megalithic wall north of the Black and White Staircase, an interpretation that differs from those proposed in Rick et al. (1998:201).

The stonework and placement of the Black and White Staircase, and its salients to north and south, in relation to the megalithic wall suggests that the Black and White Staircase was built in a phase after the megalithic wall. Seams between the megalithic wall and the salients of rough stonework north and south of the Black and White staircase indicate that the staircase and salients were built up against the previously existing megalithic wall; the megalithic wall clearly runs behind the salients of the Black and White Staircase (Figure 5.17 - 5.20). Additionally, the Black and White Staircase is not centered in the Plaza Menor Terrace, suggesting that the staircase was not originally built with the megalithic wall; the megalithic wall measures 39.77 m to the north, where it meets the Middendorf Staircase wall, and 42.59m to the south, where it meets the doorway to the south, then turns east and continues farther south into the aluvión. In sum, the abutment of the salients of the fine granite Black and White Staircase against the megalithic wall of the Plaza Menor Terrace, along with the off-centered placement of the staircase, suggest the Black and White Staircase was built in a phase that followed the construction of the Plaza Menor Terrace.

At its north end, the Plaza Menor Terrace meets a megalithic wall that is part of the structure containing the Middendorf staircase. A clear endwall seam exists in the corner where they meet, in which the megalithic stones of the Middendorf wall run behind the small stones of the support wall fronting the Plaza Menor Terrace (Figure 5.21). This indicates that the support wall was added after the construction of the megalithic Middendorf wall, as well as the megalithic wall of the Plaza Menor Terrace. The stonework of the two megalithic walls is similar, suggesting that they may have been part of the same construction; unfortunately this currently cannot be confirmed because the megalithic wall of the Plaza Menor Terrace at this corner is blocked by the support wall. If the two megalithic walls were part of the same construction, this would mean that the Plaza Menor Terrace megalithic wall and the Middendorf structure were built at the same

time, before the Black and White Staircase. If not, it is not clear which was built first, but one could speculate that the Middendorf Staircase was earlier because it is presently off-center in its wall: a later abutment of the Plaza Menor Terrace could have made shorter the wall west of the staircase, which originally may have been as long as the wall east of the staircase.

The network of drains within the Plaza Menor Terrace likely were largely original to its construction. Vertical shafts and large canals, including the Rocas Gallery (which was partially mapped by a Stanford team led by Rick in 2000 and not included in maps here), descend from the top of the terrace and emerge near the level of the Plaza Mayor and its terrace. One channel of Rocas emerges from under the NEA (Lumbreras 1971:2). This network of drains suggests that the terrace and its drain system were built together, in part to channel water down and east towards the river.

The surface structures on the top of the Plaza Menor Terrace align with the Black and White Axis (Rick et al. 1998). These features including the Plaza Menor, the Black and White Portal, and the Black and White Zócalo, or low fronting platform north and south of the Black and White Portal, at the base of the east face of Building A. "Zócalo" (English: "socle") is the term used by Tello (1960:Figure 6, 130) to describe this feature. The Plaza Menor likely was square (Rick et al. 1998), and contains fine stonework similar to that in the Circular Plaza and the Plaza Mayor (Pozorski and Pozorski:1987; Rick et al. 1998).

The Plaza Menor Terrace extends south of the SA, but whether it was built before, at the same time as, or after Building A reached its full southern extent is unclear.

The Plaza Mayor and Plaza Mayor Terrace

The Plaza Mayor aligns with the Black and White Axis (Figure 5.22). In fact, on its east staircase lies a marker that aligns with the center dividing line of the Black and White Portal, and apparently formed the east reference point for the axis (Rick et al. 1998:199, Figure 14).

The floor of the Plaza Mayor forms the lowest formal level in the site. East of the Plaza Mayor, within the surrounding the Plaza Mayor Terrace, four drainage canals intersect (Figure 5.23 - 5.25). The primary drain runs east to the river, and is constructed with ceiling lintels, stone walls, and a stone-lined floor similar to those in the drains in the temple buildings. Other canals meet the intersection from the north, south, and west. The canal from the south curves from the west, running parallel to the south side of the Plaza Mayor. The canal from the west begins underneath the east staircase of the Plaza Mayor (Figure 5.26), connecting to the Plaza Mayor via a small opening at the base of the steps. The canal from the north may connect with an east-west canal running parallel with the north wall of the plaza. The drains that eventually meet at this intersection appear to have surrounded the Plaza Mayor, curving as they passed its east extent and connecting at the intersection with the main drain running east to the river.

The canals' location within the terrace, and the location of the west canal immediately underneath the steps of the Plaza Mayor, suggest that they likely were built at the same time as the Plaza Mayor, and that the Plaza Mayor Terrace containing them likely was built up from at least the level of the bottom of the Plaza Mayor.

Building E and Building F

As described in detail in the previous chapter, two phases of Building E (Figure 4.132) are evident. The first is a low building containing the Escondida Gallery and projecting west in the southwest corner of the building. The second is an addition to the north face and the top of the early building, containing the Cortada Gallery and the two staircases evident on its north face. A third staircase likely existed to the east, in the area of the building that has been eroded by river incursion.

Building F lies north of the Plaza Mayor (Figure 5.27). It contains three staircases that rise from the terrace surrounding the Plaza Mayor. Earlier constructions within this building have not been identified, but may be revealed with further investigation.

Building F and the second phase of Building E align to the Black and White Axis. The south face of Building F and the north face of Building E are equidistant from the Black and White Axis (Rick et al. 1998). Their staircases are precisely spaced and aligned opposite the Plaza Mayor and the Plaza Mayor Terrace, with respect both to each other and to the Plaza Mayor (Rick et al. 1998).

The Middendorf Staircase and Building F

The west staircase of Building F abuts the east wall of the structure containing the Middendorf Staircase, indicating that it was built after this structure (Figure 5.28, 5.29, 5.27 above) (Rick et al. 1998). The east wall of the Middendorf structure aligns at an angle different from those in the rest of the east area (Rick et al. 1998).

Building D

Building D does not abut other structures, nor is it situated symmetrically or in apparent planned relationship with other buildings of the Black and White Axis (Figure 5.30). Rowe (1962, 1967) postulated that Building D was a late construction. Given the precise alignments and highly planned nature of structures aligned to the Black and White Axis, however, I argue that the very fact that Building D does not align significantly with the Black and White Axis or structures that align with it, suggests that Building D was an early structure. Consistent with this argument is the fact that the northeast corner of Building D does align with the east edge of the Middendorf Staircase and the west wall of the early phase of Building E. Because both these structures are

built prior to those aligned with the Black and White Axis, these alignments suggest that Building D may have been earlier as well.

Building G and the Bennett "Cells"

Only the northwest corner and walls remain of Building G, a platform sitting east of the Plaza Mayor (Figure 5.31 above, 5.32, 5.33). Based on the proximity and alignment of this corner of Building G with the southeast corner of Building F (Figure 5.34), it appears that Building G likely spanned the distance between the Building F and the late phase of Building E, and that it likely was constructed with them in relation to the Black and White Axis.

Within Building G, Bennett (1944:78-80, Figure 25, Figure 27, Plate 6C) describes the remains of a structure with at least six connected “cells,” beneath the floor of which he found a charcoal layer associated with “Chavín sherds.” The north wall of the structure, which connected the cells, was aligned with the center of the Plaza Mayor, and extended east from the west wall of Building G approximately 20.75 m until it reached the bank of the Rio Mosna, which apparently had eroded other cells (1944:78-80, Figure 25, Figure 27). Describing one of the cells, Bennett states that it

“is rectangular, measuring 1.4 meters wide and 1.82 meters deep. Rough stone walls outline three sides and the fourth, on the north, is open. The walls, about 35 centimeters thick, are not as well made as those in the Castillo galleries, but are about the same workmanship as the galleries in the south plaza platform. Two large slabs serve as covers, one placed flush with the front opening” (Bennett 1944:80).

Although he states that “there is no indication that these cells were originally part of a subterranean gallery” (Bennett 1944:80), based on his description and plan of the walls, stonework, slab roof construction, and the layout of the cells, as well as a photo of parts of the cells (Bennett 1944:Plate 6C), I hypothesize that these cells were indeed a part of a gallery. Together with the lack of evidence of a wall opposite the cells that would have formed a hallway, which I suspect was Bennett’s reason for believing this was not a gallery, the construction of

these cells suggest that this may have been an unfinished gallery, left in the process of being constructed. If so, this gallery may have been constructed quite late in Chavín's sequence. The alignment of the north wall of the structure with the center of the Plaza Mayor suggests that the structure may have been aligned to the Black and White Axis. The size, form, and spacing of the cells, their construction, and the placement of the roofing slabs over them are very similar to the Ofrendas Gallery in the Circular Plaza Atrium.

East Area Chronology

The above analyses indicate that the East Area can be divided into three phases. The first is referred to here as the East Area Black and White Axis phase, in which structures were built aligned to the Black and White Axis, and the second is referred to as the East Area Pre-Black and White Axis phase, in which a set of structures was built prior to the structures of the East Area Black and White Axis phase, and not aligned to the Black and White Axis. The East Area Pre-Black and White Axis phase includes The Plaza Menor Terrace, the Middendorf Staircase, the first phase of Building E, and likely Building D. The East Area Black and White Axis phase includes the second phase of Building E, Building F, Building G, the Plaza Mayor, the Plaza Mayor Terrace, and the surficial structures added to the Plaza Menor Terrace, which include the Black and White Staircase, the Plaza Menor, the Black and White Portal, and the Black and White Zócalo. Following the East Area Black and White Axis phase, the support wall of the Plaza Menor Terrace was added.

Greater chronological resolution within the East Area Pre-Black and White Axis phase is not currently evident, in large part because many of the structures are not contiguous and therefore do not contain chronological information provided by abutments, and in some cases because they were incorporated into the East Area Black and White Axis phase with new additions that obscured the older structures and additional chronological information they may

have contained. Future research in the East Area may be able to distinguish more phases within the East Area Pre-Black and White phase.

Chronological Relationship between East Area and Buildings A, B, and C and the CPA

An important aspect of determining Chavín's construction sequence lies in establishing how the identified phases of the East Area chronologically relate with the phases of Buildings A, B, and C, and the Circular Plaza Atrium. Understanding these relationships is essential for understanding how the site grew as a whole.

Relationship of East Face of Building A to East Area

In Building A, an important shift in architectural alignment principles appears to have occurred with the construction of its final phase. Prior to the final phase of Building A, the Columnas Patio is centered in Building A, in the north-south direction. The centeredness of this patio within Building A follows the predominant principle of centeredness and bilateral symmetry evident throughout each of the phases of Building A up to this point. Along with the centeredness and symmetry of staircases and doorways, this suggests that a pattern of bilateral symmetry and centeredness guided the placement of the Columnas Patio, centered above the east face of Building A.

In the final phase of Building A, however, this centeredness becomes obscured, and a new alignment of Building A appears. The Columnas Patio is covered with the construction of North Columnas-Vigas, causing the centered open patio to disappear. Meanwhile, at the top of Building A, the two free-standing rectangular structures are constructed. They are not symmetrical about the center point of Building A, but rather are symmetrical about the Black and White Axis: the midpoint between them aligns with the midpoint of the Black and White Portal,

and the south rectangular structure is centered over the East Face South Staircase, while the north rectangular structure is centered over the East Face North Staircase. With this final addition, Building A aligns to the Black and White Axis.

This shift in architectural alignment of the last phase of Building A to the Black and White Axis suggests that the last phase of Building A and the East Area Black and White Axis Phase were built at the same time (Figure 5.35-A)

While the Black and White Axis is marked by the midline of the Black and White Portal and a marker on the east staircase of the Plaza Mayor (Rick et al. 1998), these markers themselves appear to have been aligned to the center of the East Face North and South Staircases (see Table 5.2 for measurements). This conclusion is based on the evidence that both staircases already existed by this point in time, as supported by the construction sequence of Building A: the East Face North Staircase was built in the NWA-High NWA-MA-SA Platform phase, roughly centered within the east face of the NEA-MA, while the East Face South Staircase was built in the SA Phase, symmetrical with the East Face Gallery about the center point of the east face of Building A. The alignment of the last phase of Building A to the axis marked by the center point between these two staircases suggests that the axis itself was placed to be centered between the staircases.

The location of the Black and White Axis in the center between these two staircases represents a shift in symmetry for the east face of Building A. The distance from the north edge of the East Face South Staircase to the midpoint of Building A at the level of the CFT is 17.02 m (see Table 5.2). The distance from the south edge of the East Face Gallery to the same midpoint is 17.20. These measurements suggest that when the East Face South Staircase was constructed, in the SA phase, it was aligned to be symmetrical with the East Face Gallery about the midpoint axis of Building A. In comparison, the distance from the north edge of the East Face North Staircase to the Black and White Axis measures 15.74 m, and the distance from the south edge of the East Face South Staircase to the Black and White Axis measures 15.94 m (the north edge of this

staircase is missing, prohibiting measurement from the staircase edges closest to the axis). These measurements suggest that in the final phase of Building A and the final phase of the East Area the axis was shifted to be symmetrical instead to the midpoint between the East Face North and South Staircases. The Black and White axis sits approximately 3.45 m south of the midpoint of Building A (Rick et al. 1998).

The reasons for this shift are unclear. The shift may be related to the fact that all of the Black and White Portal is located to the south of the A-E-1 seam, and to a possible need to avoid constructing the portal in front of the NEA (Rick et al. 1998:198). It could also be due to an adaptation of the alignments of the new constructions to earlier structures east of Building A built in the East Area Pre-Black and White Phase, or to constraints imposed by the floodplain to the east. It may also be due to a motive to align the new structures to features more visually similar than the East Face Gallery and the East Face South Staircase. The East Face Gallery entrance is visually distinct from that of the East Face South Staircase: it is built in rough stonework, with the top of the entrance located one course below the CFT, and is much shorter and narrower than the East Face South staircase, which is built in fine stonework, with its base also one course below the CFT. Acknowledging the fact that the stonework around the East Face Gallery entrance looks somewhat modified, it seems unlikely that these two openings to the east face were ever visually similar. The stonework of the remaining north edge of the East Face North Staircase, however, appears more similar to that of the East Face South Staircase. The elevation of its original base is not clear, but appears as if it may have been at the same course as the base of the East Face South Staircase, one course below the CFT. Its width and height are unknown. Perhaps during the construction of the East Area Black and White Axis phase, centeredness between visually similar elements was important enough to create a new, off-center alignment, whereas during the earlier SA construction, perhaps symmetry about the center point of the building was more important than the visual matching of the symmetrical elements.

The apparent switch in alignment from the center of Building A to the Black and White Axis thus marks a significant chronological indicator that links the East Area and the latest phase of Building A, here renamed the Building A Black and White Axis phase. In addition to the alignments presented in Rick et al. (1998) and discussed above, alignments between the East Face North and South Staircases and the structures of the East Area Black and White phase demonstrate the chronological link between the late Building A phases and the east area. The north and south walls of the salients of the Black and White Staircase align with the edges of the staircases in the east face of Building A: the south wall of the Black and White Staircase south salient aligns with the south edge of the East Face South Staircase, and the north edge of the Black and White Staircase north salient aligns with the north edge of the East Face North Staircase. The north and south edges of the zócalo of the Black and White Portal are similarly aligned to these staircases. The alignment of the structures of the late phases of Building A and the East Area to the Black and White Axis indicates a high level of planning prior to their construction, in which Building A was visually and chronologically linked to the structures of the East Area.

Relationships between the East Area and Building B, Building C, and the Circular Plaza Atrium

Between the East Area and Buildings B, C, and the Circular Plaza Atrium, few direct links are apparent. Levels within the areas do have similar elevations. The current surface of the Plaza Menor Terrace at the base of the Black and White Portal sits at approximately the same elevation as the base of the A-E-1 seam, the base of the Circular Plaza, and the exposed northeast corner of Building D. Although the tops of the megalithic wall of the Plaza Menor Terrace and the Black and White Staircase are eroded and missing, they appear to have continued up to this elevation as well. The base of the Plaza Menor lies approximately 1.45m below this level. The ceilings of the three galleries in the Circular Plaza Atrium and the top of the Circular Plaza align

with the top of the SA Platform, as well as with the top of the zócalo of the Black and White Portal.

Chronological links between these areas become more apparent upon examination of patterns that emerge in the site-wide sequence, presented in the following chapter.

Site-wide construction and the geologic setting

The overall division of the monumental center across upper and lower levels appears to have its foundations in the geologic form of the area on which the temple was built. A geologic study of the temple area and surrounding valley determined that structures of the East Area, including Buildings E, F, G, and the Plaza Mayor, were constructed on a geologic flood plain that is bounded to the west by an ancient river scarp visible southeast of Building A and northeast of Building D (Turner et al. 1999:53, Figure 3). The river scarp curved across the area in front of where Buildings A-D now stand. This suggests that the elevation divisions within the temple have their origin in the geologic surfaces of the area, and that the structures were built to adapt to and formalize the differences between. Buildings A, B, C, and D and the Circular Plaza Atrium appear to have been built on the higher surface, east of the river scarp. Buildings E, F, and G and the Plaza Mayor and its surrounding terrace apparently were built on the floodplain below and east of the river scarp. The Middendorf Staircase, the Plaza Menor Terrace, and the Black and White Staircase transition between the two surfaces, and likely were constructed up from the floodplain, against the scarp.

Construction of Buildings NWA-B-C: 2000 Excavation Proposals and Results

Because the west wall in the NWA-B-C area is largely absent, decrepit, or buried, hypotheses were developed to predict locations of possible seams along the west wall in these

areas, based on analysis of three-dimensional data along with construction principles revealed in the above analyses. Excavation locations were proposed to gather more external data regarding the construction of Buildings B, C, and the NWA through small-scale, strategic excavations carried out during the 2000 season led by Rick. Each proposed unit tested a hypothesis regarding the construction of this area, with the goal of identifying early forms of Buildings B and C. For example, the construction sequence presented for Building B in the previous chapter, in which Building B originally took the form of a separate low platform, suggests that a seam was created in the west wall with the addition of the NWA. A seam plane defined by the Lab-E-1 seam in Laberintos projected onto west wall was proposed as a possible location for an early south wall of Building B, along with a north counterpart equidistant from the Lanzón Gallery. This is a plausible suggestion, as internal seams have proven to correspond with exterior seams, such as the Portada entrance with A-W-1 and A-E-2. These and other hypotheses formed the basis for proposing excavation locations.

This opportunity to use “virtual archaeology” to propose such new hypotheses and test them in the field furthered knowledge of the temple growth, but to a limited extent. For example, the excavation at a vertical disjunction (whose top sits at the same elevation as the top of A-N-1) on the west face opposite Murcielagos was successful in revealing that the feature was not a seam, indicating that the NWA exterior does correspond with the interior data, and thus that the NWA continued north at least to the Lab-E-1 seam in Laberintos. The original exterior walls in other units, however, were blocked by historic-period walls or modern support features, and thus could not be examined. Future excavations that carefully dismantle these features that block the original walls would be required to determine whether or not exterior seams exist here.

Summary

Centered and bilaterally symmetrical staircases are a key architectural principle at Chavín. They can be used to determine the order of construction of some areas of the temple. The construction of the staircases of the east face of Building A demonstrates the ongoing accommodation and modification of this face to adapt to construction principles as the temple is expanded.

In the East Area, a set of structures aligns with the Black and White Axis. The Black and White Axis itself aligns with the center point between the East Face South and North Staircases, and its marked by the midline of the Black and White Portal and a marker on the east staircase of the Plaza Mayor. The structures that align with this axis appear to have been built in one phase, the East Area Black and White Axis Phase. Other structures in the east area, like Early Building E and the Plaza Menor Terrace, predate the structures built in the East Area Black and White Axis Phase, and are grouped as the East Area Pre-Black and White Phase. These buildings undergo significant additions and modifications to align with the new axis in the East Area Black and White Axis Phase. In the final phase of Building A, the earlier centeredness principle followed within Building A shifts to an alignment with the Black and White Axis, south of the center point of the east face of Building A. This shift chronologically links the East Area Black and White Axis Phase with the final phase of Building A, renamed the Building A Black and White Axis Phase.

CHAPTER 6

SITE CONSTRUCTION SEQUENCE AND GALLERY STANDARDIZATION

In the previous chapters, phases within Building A, Building B, Building C, the Circular Plaza Atrium, and the East Area were isolated and sequenced within each building or area. Chronological links then were established between these some of the phases in different areas. In this chapter, these isolated and sequenced phases are summarized and then presented as a site-wide sequence. Within this sequence, it becomes clear that phases in some areas “float” within large expanses of the sequence. In order to fix these phases in time, the sequence is examined at a site-wide level, looking at changes in the architecture over time to establish a greater time resolution for those floating phases. The resulting architectural pattern, the standardization of the galleries, enables the floating phases to be better fixed in time and thus establishes a more precise architectural sequence. Within this sequence, the many individual phases can be grouped within larger, more general site-wide construction stages.

Chronological Narrative of the Construction of Isolated Phases, Including Galleries, by Area

The construction phases that were isolated and sequenced in earlier chapters are summarized here, according to their area within the site. The forms of these phases are described, along with the galleries that were built in them as well as major modifications to earlier phases that were incorporated during the construction process. Relationships that chronologically link phases in different building areas to each other are summarized after the description of the area sequences. These phases and their chronological relationships to each other, as suggested by evidence presented thus far, are sequenced in Table 6.1. The galleries of these phases are

sequenced in Table 6.2. An isometric reconstruction of this initial sequence is shown in Figures 6.1 - 6.11.

Building A

1. The NEA Phase is built to the full height of its main platform, on the high terrace west of the river scarp. All NEA galleries – Escalinata, East Face Gallery, Alacenas, Zanja, and their vents – are built at this time as an integral part of the construction. Escalinata and the East Face Gallery are staircases built to the top of the platform. Escalinata serves as the entrance to the building, and its entrance is centered with respect to the north face of the NEA. The East Face Gallery is a hanging staircase centered in the east face of the NEA. Alacenas is placed so that its vent is centered in the relieving window of Escalinata. The stonework at this time is rough on all faces. The East Face North Staircase, the hanging staircase south of the East Face Gallery, does not exist at this time.

2. The NWA-High NWA-MA-SA Platform Phase is built abutting to and connecting Building B and the NEA. It abuts the NEA at the A-E-1 external seam on the east face and at the A-N-1 external seam on the north face, with the batter of both seams indicating the NEA was built first. This phase includes the High NWA, Upper Laberintos, Upper Pasos Perdidos, the Marino Gonzalez Staircase, Murcielagos, Gallery XIII, Lower Liticos, and Lower Portada. The entrance to Murcielagos opens just above the level of the MA and is centered within the south face of the High NWA, in rough stonework. The High NWA also contains the upper reaches of the vertical drainage shafts of Upper Pasos Perdidos. Lower Liticos and Lower Portada both descend from the top of

the MA. Lower Portada is a hanging staircase centered in the fine stonework of the south face of the MA.

Much modification of the NEA occurs in this phase. The west top edge of the NEA is partially deconstructed to accommodate the east portion of Upper Laberintos and the Upper Pasos Perdidos. The coarse stonework on the east face of the NEA is deconstructed down to the level of top of the lintel of the East Face Gallery. Above this level the east face of the NEA is rebuilt in fine stonework, matching the fine stonework used to build the high portion on the south face of the MA. The East Face North Staircase is built in fine stonework, centered within the now-combined east faces of the NEA and the MA. The rough stonework on the north face of the NEA is not dismantled. The tenon heads are likely built on the new addition, as implied by continuation of the tenon head course from the SA across A-W-1 into the MA on the west face, and perhaps by the alignment of the pegs in Upper Laberintos to this level as well.

The NWA-High NWA-MA-SA Platform exists at the same time as Middle Building B. They sit at the same level and both open to the Lanzón Patio atop the east platform of Building B, suggesting they were used at the same time. The similar stonework in Middle Lanzón and Upper Laberintos strongly suggests they were built in the same phase.

3. The High NEA Phase is constructed on top of the NEA and abutting the High NWA to the west. This platform is centered within a meter or two of the NEA-MA block, suggesting it was not built with the NEA, but only after or at same time as the joining of the NEA-MA. The Murcielagos doorway, centered in the south face of the High NWA, indicates that the High NEA was built after the High NWA. This is consistent with the different stone types in their north walls. The High NEA is built before the High MA galleries, which later are built up against its south wall. It is likely built before the SA,

given the symmetry it creates with the High NWA with respect to the MA. When the High NEA is built, the south entrance steps to Alacenas are blocked, necessitating the creation of a new entrance through the east segment in this gallery.

4. The SA Phase is built abutting the south face of the MA and on top of the SA Platform. This includes Lower Doble Mensula and the Caño Gallery. The South Face Staircase is built centered in the south face of this addition, replacing the Lower Portada entrance as the hanging staircase on the south face. The East Face South Staircase and the cornice and tenon head courses on the SA are included in this phase.

5. The High MA Phase is built, containing Cautivos, Upper Liticos, Upper Portada, South Columnas-Vigas, and the Columnas Patio. The Columnas Patio is centered in Building A, in the north-south direction. A layer of pegs is placed in the south wall of the High NWA, and Cautivos is built up against this south wall, enclosing the entrance to Murcielagos. South Columnas-Vigas and the Columnas Patio are built up against the south wall of the High NEA. Upper Liticos is built above Lower Liticos.

6. The High SA Phase is built, containing Upper Doble Mensula and blocking off numerous vents that trend south from the High MA galleries. The SA and Lower Doble Mensula are partially deconstructed to connect Lower Doble Mensula with Upper Doble Mensula.

7. Building A Black and White Axis Phase: The Columnas Patio is covered with the construction of North Columnas-Vigas, obscuring its centered alignment. The north and south free-standing rectangular structures on top of Building A are built, aligning Building A to the Black and White axis.

8. Support fill construction is built up against the west wall of Building A, well after Building A had reached its full southern extent.

Building B and the Circular Plaza Atrium

1. The B Platform and the Inner Lanzón Rectangle are built, in the B Platform-ILR Phase. The Inner Lanzón Rectangle is a free-standing rectangular structure located on top of the west portion of the platform, opening to the east.

2. The WB-MB Phase is built, consisting of West B and Middle B. In this phase, the Inner Lanzón Chamber episode and the Middle Lanzón episode are constructed, converting the Inner Lanzón Rectangle into a gallery. Building B now takes the form of a stepped platform, with the Middle Lanzón and Inner Lanzón Chamber in the raised portion to the west, stepping down to the Lanzón Patio to the east. The entrance to the Middle Lanzón is plastered and opens directly to the Lanzón Patio. The Lanzón monolith most likely is in place by the end of the construction of the WB-MB phase, if not before. The pegs in the walls of the Inner Lanzón Chamber align with the surface of the Lanzón Patio and the floor of the Middle Lanzón, as well as with the belt on the Lanzón monolith.

Upper Laberintos, built in the NWA-High NWA-MA-SA Platform phase of Building A, also opens directly to the Lanzón Patio, from the south, and likely is built at the same time as the Middle Lanzón episode. This suggests that the WB-MB Phase and the NWA-High NWA-MA-SA Platform phase of Building A are built at the same time as well.

3. The EB-High B-CPA Phase is constructed. The Lanzón Patio is filled-in with the construction of Outer Lanzón and Lower Laberintos on top of its surface, abutting with the entrances to Middle Lanzón and Upper Laberintos, in the east portion of B. Additionally, Building B is raised, creating High B. Gallery VIII is constructed directly above the Inner Lanzón Chamber. The north wall of the NWA and the ceiling of the staircase of Upper Laberintos are deconstructed to enable the construction of the Laberintos Alcove, connecting the upper level of the gallery and High B. The upper portion of the Circular Plaza Staircase is built as a covered staircase in the center of the east face of Building B, spanning the elevations of both EB and High B. The staircase climbs up at least to the level of Gallery VIII, likely connecting with vents from Outer Lanzón and Gallery VIII. The entrance to the Lanzón Gallery, which previously had been centered in Building B, is diverted to the south within the Outer Lanzón, likely to accommodate the upper portion of the Circular Plaza Staircase.

The Circular Plaza Atrium phase is built, containing the bottom portion of the Circular Plaza Staircase, the Circular Plaza, the Circular Plaza Terrace, the galleries within that terrace – Ofrendas, Campamento, and Caracolas – and smaller spaces of ventilation shafts and drains. All of these structures are built as a unit within the area between Building A, Building B, and Building C. The Circular Plaza Terrace blocks the entrance to Escalinata at the base of the north wall of the NEA

The upper portion of the Circular Plaza Staircase, within Building B, integrates directly with the lower portion of the stairs, within the Circular Plaza Atrium; evidence suggests the upper and lower portions of the staircase were built in one phase. The staircase physically and chronologically links the EB-High B phase of Building B and Circular Plaza Atrium (CPA) phase together in one larger phase.

The EB-High B-CPA phase clearly was built after the NEA, as shown by the Circular Plaza Terrace blocking the entrance to Escalinata. Because it was also built after

the WB-MB Phase, which is likely built with the NWA-High NWA-MA-SA Platform phase of Building A, the EB-High B-CPA therefore is also likely built after the NWA-High NWA-MA-SA Platform. After this phase of the Building A sequence, the construction of the EB-High B-CPA floats in time. The examination of site-wide architectural patterns, below, anchors this phase in the site-wide sequence.

4. The Circular Plaza Atrium appears to undergo a period of support constructions (Lumbreras (1977:10; 1993:Figure 3). Walls are built against the lower part of the east face of Building B near the Circular Plaza Staircase and against the north and south sides of the staircase where it emerges from Building B into the Atrium. These walls are associated with Level H, the level immediately above the floor of the Circular Plaza and above the Circular Plaza Terrace (Lumbreras (1977:10; 1993:Figure 3).

Building C

1. The Low Building C Phase is built containing Lower Loco. The free-standing rectangular structures built in the Rooms episode of Loco appear to have stood as separate units atop Low Building C. The relationship of this phase to other phases floats in time somewhat. It may be in place by the completion of the NWA-High NWA-MA-SA Platform Phase in Building A and the WB-MB Phase in Building B, as part of a U-form created when the NEA and the B Platform-ILR phases are joined. As described previously, this likely is not the earliest form of Building C; further refinement of its form and chronological relationships awaits excavation of the exterior walls of this building.

2. The High Building C Phase is built. In this phase the Rooms of Upper Loco are connected and converted to portions of an internal gallery with the construction of the

South Loco episode. The North Loco-Mirador episode is constructed some time after South Loco, and likely connects with a Loco Patio to the north.

3. In the Building C support construction phase, a megalithic wall is built up against the west wall of Building C, at a height suggesting it was built after Building C was complete.

East Area

1. The construction of the East Area is divided into two groups based on the alignment of those groups in relation to the Black and White Axis. The first of these, the East Area Pre-Black & White Axis Phase, consists of those buildings that were built not aligned to the Black and White Axis. Their construction relative to the buildings built aligned to the Black and White Axis demonstrates that they were built before the structures that align to the Black and White Axis. Early Building E likely is built on the low terrace or flood plain that formed east of the ancient river scarp. The Plaza Menor Terrace is built up, likely from the flood plain level, as indicated by the network of drains and the Rocas Gallery descending through it down towards the Rio Mosna. It and the Middendorf Staircase structure appear to be built directly over the ancient riverscarp and associated bedrock, creating a formal transition between the two geologic surfaces. Direct contact of Building E, the Plaza Menor Terrace, and the Middendorf Staircase structure with constructions from the East Area Black and White Axis Phase show they are earlier than the East Area Black and White Axis Phase. Because Building E is not contiguous with the Plaza Menor Terrace or the Middendorf Staircase structure, a clear chronological order between them within this phase is not clear. The original intersection between the Plaza Menor Terrace and the Middendorf Staircase structure is blocked from view by a

later support wall built against the Plaza Menor Terrace, so the construction of these two contiguous structures is not known. Based on the fact that the Middendorf Staircase is not centered within its surrounding structure, one can speculate that it may have been constructed prior to the Plaza Menor Terrace, originally centered within the surrounding structure. Building D is placed as Pre-Black and White because of its lack of symmetry with other structures; symmetry is a primary characteristic of the buildings in the East Area Black and White Axis Phase. Building D contains Upper and Lower Tello Galleries. Early Building E contains the Escondida Gallery.

2. The East Area Black and White Axis Phase is built, in which numerous structures are built aligning to a new axis that is centered not with respect to Building A but with respect to the center point between the East Face North and South Staircases of Building A. These include the Black and White Portal, the Black and White Zócalo, the Plaza Menor, the Black and White Staircase and its salients, the Plaza Mayor Terrace, the Plaza Mayor, Late Building E with its triple staircases, Building F or at least a late phase of Building F that includes its triple staircases, and Building G. A network of drains continues the drainage system to the river. These structures are surficial, covering a wide area but consisting of little volume. They are highly symmetrical and stylized, with fine stonework in the Black and White Portal, the Black and White Zócalo, the Plaza Menor, the Black and White Staircase, and the Plaza Mayor. Late Building E contains the Cortada Gallery. Building G contains the “cells” reported by Bennett (1944:78-80, Figure 25, Figure 27, Plate 6C) which may have been part of a gallery, possibly unfinished.

The last phase of Building A, the Building A Black and White Axis Phase, aligns to the Black and White Axis as well, and was built at the same time as the East Area Black and White Axis Phase

3. In the East Area, a support wall is constructed between the Middendorf Staircase structure and the north salient of the Black and White Staircase, supporting the original east megalithic wall of the Plaza Menor Terrace.

Chronological links between areas

Briefly summarized, the primary chronological links presented above that enable the phases from different areas to be sequenced with one another include the following:

-The NWA-High NWA-MA-SA Platform is likely built at the same time as the WB-MB; together, the NWA-High NWA-MA-SA Platform and the WB-MB are here grouped and referred to together as the Expansion Stage, because they connect the NEA and Building B, and extend Building A to its full south extension.

-The NEA and the B Platform-ILR are both built before the Expansion Stage.

-The Circular Plaza Atrium is built after the NEA, in the same phase as the EB-High B; the EB-High B is built some time after the Expansion Stage; this means that the EB-High B-CPA Phase is built not only after the NEA but also after the Expansion Stage.

-Lower Building C likely is built by the end of the Expansion Stage.

-The SA, the High MA, and the High SA fill out the south portion of Building A, building on top of the Expansion Stage. The High NEA is built on top of the NEA, after the Expansion Stage and before the High MA.

-The Building A Black & White Axis Phase, the final phase of Building A, is built at the same time as the East Area Black & White Axis Phase.

-The Building A support constructions and the East Area support constructions are both built after the Black & White Axis phases of their respective areas.

The high-level result of this initial sequence is that the Expansion Stage physically separates subsequent constructions in Building A from those in Building B and the Circular Plaza Atrium. The very vastness of its construction becomes a barrier between the south portions of Building A and the areas to the north. These means that the contiguity that provides the relative sequence evidence for phases within each individual area, as listed above, is not available between areas. Of particular importance is the fact that the EB-High B-CPA phase floats in time after the Expansion Stage: it is clear that it is built after the NEA, because the Circular Plaza Terrace blocks the entrance to Escalinata, and it is clear that it is built after the Expansion Stage, because the EB-High B follows the WB-MB, as described above. How much later the EB-High B-CPA phase is built after the Expansion Stage is unclear based on the evidence presented thus far. Similarly, High Building C floats relative to the phases in other buildings, likely being constructed some time after the Expansion Stage.

Analysis of the orientations of the NEA and Building B suggests that the NEA was built first. The form and location of the Escalinata Staircase, with its grand entrance and relieving window centered in the north face of the NEA, suggests the NEA originally was oriented to the north. It is the only phase that is clearly oriented to the north in the main temple complex. The other buildings, including Building B and perhaps excluding High Building C with its north-facing Loco Patio, are oriented to the east. Because the latest phases also are primarily oriented to the east, an orientation shift likely occurred some time after the building of the NEA.

Patterns Within the Gallery Sequence: Gallery Standardization

By analyzing the gallery episode sequence within the site sequence and discerning patterns that emerge within the galleries over time, physically separated construction phases can be associated chronologically. This enables some of the “floating” phases to be anchored in time, resulting in a more precise chronology of the site as whole. This analysis technique is applied to

anchor the EB-High B-Circular Plaza Atrium Phase in the sequence. It is also used to help establish the chronology of Building C relative to the other buildings.

A significant pattern emerges in the gallery sequence when the galleries' forms, features, and construction techniques are considered chronologically. In the early phases, the galleries' forms, features, and construction techniques are highly variable and frequently elaborate, particularly in and prior to the Expansion Stage. After the Expansion Stage this variability and elaborateness begin to diminish. In the final phases of the sequence these characteristics are refined to a simple, standardized set of forms and features constructed in a similar manner. (See Table 6.2 for a list of the galleries present in the various construction phases. See Figure 6.12-A for a visual summary of the process of gallery standardization.)

Galleries in the early phases of the sequence are characterized by variability of form, feature types and placement, and construction techniques. Innovation in gallery construction results in unique forms or combinations of features. For example, the Escalinata Gallery in the NEA, one of the earliest phases and the earliest in Building A, is a massive gallery whose form and construction are unique within the site. Its internal double staircases, which connect ground level to the top of the NEA, align parallel to the north face of the NEA before meeting and descending northward through a single staircase. It is the only example of an internal staircase parallel to the building face, and the only example of an internal double staircase at the site. Construction techniques used here are also unique within the context of the site, including tie beams to stabilize the tall, battered internal walls, and a relieving window over the main entrance to reduce the burden on the lintels below. The relieving window also likely served a visual purpose, sitting directly over and approximately the same size as the north entrance below it, both centered within the north face of the NEA. The relieving window was integrated with the placement of the Alacenas Gallery and its east vent, which aligns in the center of the relieving window. On the whole, the Escalinata Gallery is the grandest, most monumental gallery construction at Chavín.

A number of other examples of early variability in gallery form and features exist. For example, the Alacenas Gallery contains a series of niches placed in a row around its walls. The small size, number, and arrangement of these niches is unique within the site. Another unique arrangement of features occurs in the Murcielagos Gallery, with its stacked double rows of vents, each containing three vents connecting segments within the gallery; such a multitude of vents in such an arrangement does not occur in other galleries known to date. In the Inner Lanzón Chamber, variability occurs as a unique cruciform space, created by a construction technique of filling-in a freestanding rectangular structure (the Inner Lanzón Rectangle) with support blocks at its corners to create a space that could be spanned by ceiling lintels. Prominent pegs, unusually placed vents and niches, and the Lanzón monolith itself are the features that accompany this unique form. In the episodes of the Loco Gallery, unusual forms and construction techniques are found: examples include the set of five small rectangular structures of the Rooms phase at the west of the gallery, the central support “column” in Segment S, the square areas to the east, and the presence of North Loco directly above Lower Loco. In the Upper Laberintos episode unusual features include pegs and doorway pegs, as well as the integrated connection with Upper Pasos Perdidos and the postulated hydraulic-acoustic function of this system (Lumbreras et al. 1976). One of its vents passes directly beneath the raised floor of a segment in Murcielagos. Finally, some early gallery episodes contain varied architectural alignments, including the varied alignments in Escalinata, Alacenas, Murcielagos, the Laberintos south-trending vents, and the phases of Loco.

While this variability, innovation, and experimentation in form, features, and construction technique is evident in these early phases, some characteristics do emerge here which persist throughout the construction phases. The first of these is the bent hanging staircase form, which first appears as the East Face Gallery in the NEA. This form continues through to the late phases of Building A. The vertical drainage system, in place at least by the NWA in the form of Upper Pasos Perdidos and Gallery XIII, also continues late into the sequence, as Caño in the SA phase.

Additionally, galleries are planned here in relation to the vents that connect them, such as between Alacenas and Escalinata, and between Upper Laberintos and Upper Pasos Perdidos, a pattern that continues into the later phases of the sequence. Finally, many of the construction principles are established early, such as centered staircases, stepped ceilings over staircases, and gallery entrances via descending steps. Emerging amid the variability of the early phases, these principles stay consistent through the sequence.

Murcielagos, Upper Laberintos, and Upper Pasos Perdidos belong to the Expansion Stage. These galleries show signs of a transition to standardization, containing both idiosyncratic and increasingly standardized characteristics. Its galleries contain both innovative and unique characteristics. For example, Murcielagos' segments are skewed with respect to architectural alignments and with respect to each other. Its side segments are also different lengths, with three on the west side and only one on the east. It also contains a unique set of stacked vents that continue through east of the west segments. Nonetheless, its basic form appears in later phases, albeit modified: the long straight segment with smaller segments branching off it in one or both directions. Upper Laberintos is elaborate in form and features, containing a large suite of features: its connection with Pasos Perdidos, pegs, doorway pegs, vents, and niches. The number of features is reduced in galleries built in later phases, but elements of its form persist and are developed in later phases, such as its winding layout of segments and rooms as well as its diminished, regular spacing of the fill between segments.

In the phases of Building A that follow the Expansion Stage, gallery forms, features, and construction techniques become increasingly standardized. The skewed alignments of the earlier phases are not present, while the area between the galleries is more regular. For example, Lower Doble Mensula is a combination of the salient characteristics of Upper Laberintos and Murcielagos: the winding passageways, standard fill size between segments, and a room are reminiscent of patterns established in Upper Laberintos, while the overall form of the east-west segments follows that of Murcielagos, as a long hallway with branching side segments. In the

Upper MA, forms, features, and construction become increasingly standardized but retain non-standardized idiosyncracies. The spacing of the gallery segments as well as the space between them is regular and even, but the gallery forms display some variability, such as the bending "L-shaped" segments in Cautivos, the alternating orientation of the connected rooms in Upper Liticos, as well as South Columnas-Vigas and the Columnas Patio. The features also display some variability, such as the large niche above the stairs in Upper Liticos, and the pegs, peg blocks, and large niches in Cautivos. Vents, however, are the most common features. The construction technique shows some unusual features such as the half-seams in Upper Liticos.

In Building A, standardization reaches its peak in the latest phases, with the construction of Upper Doble Mensula and the construction of North Columnas-Vigas, filling in the Columnas Patio. These two gallery phases represent two standardized forms. Upper Doble Mensula is a long hallway with short segments branching off one side, like an "E" or "comb" form, while North Columnas-Vigas is a long hallway with short segments branching off both sides, like an "H" form. In both galleries the feature set is reduced to only simple, single vents: Upper Doble Mensula's vents continue south, through the south walls of the short segments and the wall at the top of the stairs, while North Columnas-Vigas contains a single remaining vent. In Upper Doble Mensula, the entrance is on the east end of the gallery as the short segments point south, or on the "left" side of the gallery as the short segments point "up". In terms of construction technique, an example of increased efficiency exists. The construction of North Vigas-Columnas requires less resources and energy by incorporating earlier external walls. It abuts directly up against the south wall of the High NEA with no modifications to the wall, whereas in Cautivos, the gallery abuts against the south wall of the High NWA but only after the wall is modified to accommodate the pegs of Columnas. Lower Doble Mensula, built in the SA, contains the standardized "E" form in its north segment, but incorporates bending hallways and a small room, reminiscent of Upper Laberintos. It also contains a series of large niches along its walls; vents are embedded in some of these, creating a unique combination of features. Lower Doble Mensula also contains a set of

interior vents that extend through the gallery to the outside, similar to those in Upper Laberintos. Upper Doble Mensula is standardized in form and features, reduced to just the “E” form with single vents extending to the exterior.

How do these patterns relate to those in the EB-High B-Circular Plaza Atrium phase? The forms and features of the galleries in the EB-High B-Circular Plaza Atrium phase closely resemble those in the latest phase of Building A, Upper Doble Mensula and North Columnas-Vigas. They follow the standardized forms that emerge late in the Building A sequence, namely a single hall with short segments on one or both sides – the “E” or “H” forms – with features limited almost exclusively to simple, single exterior vents. The galleries that have segments branching from only one side are oriented such that upon entering the gallery the segments extend to the left. In the EB, Lower Laberintos and Outer Lanzón both follow this form, with simple vents extending east out the gallery. Lower Laberintos also contains two doorway pegs in its central segment, perhaps imitating those of Upper Laberintos. The destroyed Gallery VIII, as described by Tello (1960), followed the “H” form, apparently with a single vent extending east out of the gallery. The Laberintos Alcove is not well-preserved, but its original portion contains no features and appears as if it may have continued east and north; it thus is not inconsistent with the standardized forms. In the Circular Plaza Atrium, the Ofrendas Gallery is perhaps the epitome of a standardized gallery, following the “E” form, with single vents extending out of alternating short segments that extend left from the entrance. The remains of Campamento follow the “H” form, and its collapsed segments indicate that the gallery continues to the north and the east, consistent with this form. It contains small vents connecting between segments and out the gallery. Only a small segment of Caracolas is preserved, but its single exposed segment likely continues farther east. It contains simple vents extending west and north, as well as three niches.

In sum, the “E” forms of Lower Laberintos, Outer Lanzón, and Ofrendas are strikingly similar to the “E” form of Upper Doble Mensula. Within this group, Outer Lanzón and Upper Doble Mensula resemble each other with wider spaces between shorter side segments, while

Lower Laberintos and Ofrendas both contain smaller spaces between longer side segments. North Columnas-Vigas, Campamento, and Gallery VIII all follow the “H” form of a single hall with segments on both sides. Features in these galleries are limited largely to single vents that provide a direct connection to the exterior. Lower Laberintos contains interior vents to connect its segments with the exterior to the east, since the other directions are surrounded by constructions. Variations in features likely are a result of accommodating the new space to characteristics of connected earlier phases, such as the doorway pegs in Lower Laberintos that echo those in Upper Laberintos, and the columns and surrounding area in North Columnas-Vigas that fill in the earlier plaza. The galleries in the EB-High B-Circular Plaza Atrium Phase clearly contain standardized forms, feature types and placement, and construction techniques.

The presence of these standardized galleries in the EB-High B-Circular Plaza Atrium Phase has two important implications. First, it reinforces the earlier conclusion that that the EB-High B and Circular Plaza Atrium phases were built at the same time, linked by the Circular Plaza Staircase. Second, it indicates that these phases most likely were built at the same time as the latest phases in Building A, specifically the High SA Phase and the Building A Black and White Axis Phase, when standardization of gallery form, features, and construction techniques were at their peak and most similar to the standardization present in the EB-High B-Circular Plaza Atrium galleries. The standardized forms, features, and construction techniques of the galleries in the EB-High B-Circular Plaza Atrium Phase clearly are closely linked chronologically with those of the latest phases of Building A. From this, it can be concluded that the EB-High B-Circular Plaza Atrium Phase was built at the same time as the High SA Phase and the Building A Black and White Axis Phase, the latest phases of Building A (Table 6.3).

The standardization pattern can also be used to examine the gallery construction episodes in Building C to try to gain more clarity on how Building C fits with the rest of the sequence. Lower Loco is clearly earlier than the other episodes of Loco, but its form has not been revealed enough to be able to analyze it with respect to the standardization pattern observed in Building A.

The Rooms of Loco appear to have been originally small freestanding single-room buildings on top of the mound, that later were encased in an upward extension of the mound, connected by hallways in the South Loco phase, and subsumed into the larger complex. Their construction shows signs of experimentation with different construction techniques, suggesting they were early constructions. Neither South Loco nor North Loco contains standardized forms. The alignment of North Loco is skewed from the rest of the gallery, but it does not align with the architectural orientations of the site. Based on these patterns it appears that gallery episodes in Loco were not standardized. This suggests that Building C was completed before the phases that were standardized: the EB-High B-Circular Plaza Atrium Phase and, in Building A, the High SA and Building A Black and White Axis Phases (see Table 6.3).

Based on the chronological link between the Building A Black and White Axis Phase and the East Area Black and White Axis Phase, it would follow that the galleries built in the East Area Black and White Axis Phase would also be standardized. The single known gallery in this area, the Cortada Gallery in Late Building E, follows neither the “E” nor the “H” form; it is, however, arguably even more standardized than either the “E” or “H” forms. It is a single, long, straight hallway, with a single vent connecting to the north face of the mound. During Tello’s first visit in 1919, before the Rio Mosna had washed part of Building E away, this gallery was 50 m long – but was still only a straight hallway. In terms of efficiency of construction, which is an important element of the increasing standardization trend described above, a single hallway is even more efficient and less elaborate than either the “E” or “H” form. The single vent is consistent with the standardization pattern. Single straight hallways do not appear in any of the other phases in any significant length; Zanja, the Laberintos Alcove, and Caracolas are the straight single segments, but are very short and blocked or collapsed at one or both ends (and Laberintos Alcove and Caracolas are within the EB-High B-Circular Plaza Atrium phase, which contains standardized galleries). A possible example of another gallery built within the East Area Black and White Axis phase is Bennett’s “cells” in Building G (Bennett 1944), discussed in the

previous chapter; I postulated that these cells, which Bennett believed were not a gallery, in fact may have been part of a gallery, perhaps left unfinished. This hypothesis is based on the construction of the walls of these six connected cells and their ceilings of stone slabs, and the lack of a wall opposite them that would have formed the other side of a connecting hallway. Of interest is the fact that the form of these cells closely resembles that of Ofrendas and the standardized "E" form. If Bennett's cells were indeed part of a gallery or a gallery in the making, the gallery's form would have been highly standardized, consistent with the other galleries built at this time.

A final note regarding freestanding rectangular structures highlights an interesting trend towards standardization of interior spaces within these constructions. Early freestanding rectangular structures existed as the Inner Lanzón Rectangle and the Loco Rooms; both of these later were transformed into galleries. It is possible that Gallery VIII, which sits directly above the Inner Lanzón Chamber and is approximately the same size, may also have taken the form of a small building, built above the WB late in the sequence before being subsumed by the EB-High B phase. The internal spaces of the Inner Lanzón Chamber and the Loco Rooms are not standardized, nor was their construction with support blocks and a support column, respectively: the internal space of Gallery VIII, however, is standardized, following the "H" form (Tello 1960: Figure 17). Additionally, the north and south freestanding rectangular structures on top of Building A, built in the Building A Black and White Axis Phase, are divided into two small rooms following an "H" form as well, as was noted by (Tello 1929:Figure 18). These freestanding rectangular structures on Building A are approximately the same size as the Inner Lanzón Rectangle. These patterns suggest that freestanding rectangular structures, whether transformed into part of a gallery or kept in their freestanding form, also underwent the standardization process over the course of the sequence. Additionally, one can speculate that perhaps if construction at Chavin had continued, the Building A freestanding structures may have

been subsumed into the complex as galleries, with the addition of new phases, like the Inner Lanzón Chamber, the Rooms of Loco, and possibly Gallery VIII before them.

Final Construction Sequence

Evaluation of Construction Stages based on Gallery Standardization

Gallery standardization patterns indicate that the EB-High B-Circular Plaza Atrium Phase is built late in the site sequence, with the Building A Black & White Axis Phase and the East Area Black & White Axis Phase. These patterns also help place Building C within the sequence more precisely, suggesting its construction was complete before the construction of phases with standardized galleries. Using the gallery standardization pattern to establish these chronological links between non-contiguous phases helps finalize the full site construction sequence (Table 6.4; Figure 6.13 - 6.25 showing final sequence in computer model).

In the full site construction sequence, the three physically separate phases linked by gallery standardization and shown to be late – the EB-High B-Circular Plaza Atrium Phase, the Building A Black & White Axis Phase and the East Area Black & White Axis Phase – are grouped as the Black and White Stage. At the beginning of the sequence, the separate mounds such as the NEA, the B Platform-ILR, possibly Low Building C or an early form of it, and possibly some of the buildings built in the East Area Pre-Black and White Phase are grouped together as the Separate Mound Stage. The Expansion Stage follows this, linking together the NEA and the B Platform-ILR phases, extending Building A to its full southward extent, and possibly incorporating some form of Building C into a U-form along with Building A and EB-MB. The Expansion Stage is followed by the additions that gradually fill in Building A to become a large, rectangular platform, including the High NEA, the SA, and the High MA; these are grouped as the Consolidation Stage. High Building C likely is constructed by the end of the Consolidation Stage, prior to the construction of standardized galleries in the Black and White

Stage. As described above, the East Area Black and White Axis Phase, the EB-High B-Circular Plaza Atrium Phase, the High SA, and the Building A Black and White Axis Phase are grouped together as the Black and White Stage. They form the final monumental construction stage at Chavín. The Black and White Stage is followed by a Support Construction Stage in which support constructions are built in the East Area, the Circular Plaza Atrium, the west face of Building C, and the west face of Building A.

Discussion of Site-Wide Construction Sequence

The standardized galleries of the Black and White Stage are linked by similar architectural chronology, not necessarily by similar function. The Ofrendas Gallery was filled with offerings in an area of the temple that likely would have seen few visitors – and the form of its entrance suggests it was designed to be sealed off (Lumbreras 1993). In contrast, Outer Lanzón and Lower Laberintos served as entrance passageways to two primary galleries and likely were frequently visited, not closed to access like Ofrendas. These galleries did not have the same function, and thus their similar forms are not a result of similar functions.

The fact that the Black and White Stage includes the East Area Black and White Axis Phase and the EB-High B-Circular Plaza Atrium Phase means that all of the site's known plazas are built in the Black and White Phase: the Plaza Mayor, the Plaza Menor, and the Circular Plaza. As part of the construction of the Black and White Stage and its large open plazas, the gallery patios were covered. For example, the Lanzón Patio of the WB-MB phase, built in the Expansion Stage, is covered with the construction of the EB-High B-CPA phase in the Black and White Stage. Additionally, the Columnas Patio, built in the High MA Phase of the Consolidation Stage, is covered with the construction of the Building A Black and White Axis Phase in the Black and White Stage. The Loco Patio, likely constructed with North Loco and Mirador in the High Building C Phase, would have been completed by the end of the Consolidation Stage. Whether it

was later covered is unclear, due to the fact that its remains were largely destroyed with the 1945 aluvión.

The patterns described above indicate that the transition from elaborate galleries early in the sequence to standardized galleries late in the sequence corresponds with a switch from the construction of large buildings with relatively small gallery patios to the construction of open areas with surficial structures such as sunken plazas and open staircases. Galleries in the Black and White Stage are reduced to their minimal features, while the new plazas and other surficial structures are decorated with fine, sometimes carved stonework. These structures include the decorated Circular Plaza, the decorated Black and White Portal, the Black and White Staircase, and the Plaza Menor and the Plaza Mayor with their worked stone slabs. In the Black and White Phase, the architectural emphasis at Chavin switches from massive structures with elaborate, variable internal galleries and relatively small gallery patios to large, open, decorated external spaces with simple, standardized galleries.

A set of architectural similarities thus link the different areas included within the Black and White Phase (6.26-A). The Building A Black and White Axis Phase is linked with the EB-High B-Circular Plaza Atrium Phase via standardized galleries. The EB-High B-Circular Plaza Atrium phase is linked with the East Area Black and White Axis Phase via the sunken plazas and their similar stonework. The East Area Black & White Axis Phase is linked to the Building A Black and White Axis Phase via their alignment along the Black and White Axis. The East Area Black and White Axis Phase may also be linked with the other two phases via standardized galleries, as suggested by Cortada and the Bennett Cells, but this link remains tentative. This set of architectural relationships chronologically ties these three non-contiguous areas together into the Black and White Phase.

CHAPTER 7

INTERPRETATIONS AND IMPLICATIONS OF THE CHAVIN ARCHITECTURAL SEQUENCE

Summary and Terminology of the Architectural Sequence

The monumental center at Chavín was built in a complex sequence of at least fifteen phases. These individual phases can be grouped as stages, according to higher level site-wide patterns. The earliest stage, the Separate Mound Stage, consists of separate buildings containing elaborate galleries, as well as a freestanding rectangular structure. The large Expansion Stage consists of integrated stepped platforms that connect the earlier phases of Buildings A, B, and likely C, covering much volume and area, and containing galleries that are elaborate in form and features. The following phases, grouped as the Consolidation Stage, consist of block additions filling in the stepped platform of Building A and containing galleries whose forms and features are becoming more standardized. Spanning these three stages, in the east area, a set of early buildings is grouped as the East Area Pre-Black and White Axis Phase. In the final monumental stage, the Black and White Stage, site-wide additions of plazas, terraces, and additional staircases are built with high symmetry, decorated fine stonework, and standardized galleries. Gallery patios from early stages are filled with the added galleries in this stage. A series of support constructions follow the Black and White Stage in different areas across the site; this stage, called the Support Construction Stage, contains no additional monumental structures.

In describing this construction sequence, it becomes clear that the three-phase sequence and terms “Old Temple” and “New Temple” introduced by Rowe (1962, 1967) are insufficient to describe the richness of the construction history of Chavín. The sequence presented here represents a substantially different and more complex pattern than the three-phase sequence.

Areas previously thought to be “Old Temple,” such as the east face of Building B and the Circular Plaza Atrium, are now shown to be part of the final monumental construction stage, the Black and White Stage. Areas previously thought to be part of the “New Temple”, such as Building E, consist of more than one phase and contain more time depth than previously noted, extending back before the Black and White Stage.

Architectural Patterns and Interpretations

The architectural construction sequence enables the questions proposed in Chapter 1 to be addressed here.

High-Level Architectural Principles: What are the architectural principles at Chavín and how do they inform the construction sequence?

Numerous architectural principles and construction patterns are evident in the monumental center at Chavín, many of which have been presented in earlier chapters. The discussion here highlights some of the broader patterns and more significant principles that emerge in this study.

Integration of internal and external architecture

The principles of construction at Chavín include both internal and external constructions as part of a single design. The network of galleries and drainage canals are integrated as key components during the planning and construction of the buildings, terraces, and plazas. The placement and form of some galleries are partly dictated by the need to connect vents to the exterior. Within a single phase, galleries are sometimes placed so that their vents open to the exterior at visually significant places, such as the east vent between Alacenas and Escalinata. In new additions, such as the SA, galleries are placed and formed so that some vents from earlier

phases continue through the new constructions to the exterior, as in the case of Lower Doble Mensula and Murcielagos.

Modification and Adaptation

Modification to earlier phases occurs throughout the sequence. Most modifications serve to adapt existing architecture to new additions. Internally, modifications are carried out primarily to maintain access to galleries that would be blocked or buried by additions. Externally, modifications primarily serve to adapt older constructions to the addition of new phases, so that the combined form of old and new phases adheres to architectural principles such as centeredness or symmetry, discussed below. Some of these modifications are of local importance, while many have site-wide significance. Deconstruction is a significant component of the modification process; major portions of architecture are deconstructed and then reconstructed to adapt to the addition of a new phase.

Increased Standardization, Precision, and Alignment

Over the course of the construction sequence, levels of standardization, precision, and alignment increase, reaching their peaks in the Black and White Stage. Early galleries contain innovative and elaborate forms, features, and construction, particularly in the Expansion Stage. After the Expansion Stage, a trend towards standardized gallery forms, features, and construction begins, reaching its peak in the Black and White Stage.

The level of precision in the execution of architectural principles such as centeredness of staircases and the symmetry of features also increases. Early staircases are closely centered within the east and north faces of the NEA. In the Expansion Stage, staircases are centered, but less precisely. With the addition of the SA, staircases are centered and symmetrical much more precisely, to within a few centimeters. This precision continues into the construction of the East

Area Black and White Axis Phase, where the staircases of the Plaza Mayor, Building E, and Building F are centered and aligned precisely with each other (Rick 1998 et al).

Architectural orientations and alignments also undergo a process of increasing precision and increasing unity or standardization. The NEA is oriented to architectural north, with its monumental double staircase and its relieving window opening to the north. By the Expansion Stage, this orientation shifts to the east, with major efforts to deconstruct the east face of the NEA and reconstruct it to include the newly created East Face North Staircase, effectively centered in the combined east face of the NEA and the MA, and the coarse-to-fine transition (CFT), which decorates the east and south faces of the newly combined NEA-MA phases but not the north face. In the same stage, the Inner Lanzón Chamber is created, opening to the east and the Lanzón Patio. Alignments of some galleries and vents within the NEA and the Expansion Stage vary from architectural directions, along with the alignments of some walls of early structures in the East Area Pre-Black and White Axis Phase. By the Black and White Stage, external and internal architecture more consistently align to architectural directions.

Centeredness and Symmetry

As discussed in Chapter 5, Level 4 Analysis, the bilaterally symmetrical placement of staircases is one of the most consistent and prominent architectural principles. Centered staircases are present in each of the two visible faces of the NEA, making the faces bilaterally symmetrical. Staircases continue to be centered in later phases, sometimes requiring deconstruction of earlier phases. With the addition of the SA, the East Face South Staircase is built likely to pair with the East Face Gallery entrance symmetrically about the center point of the east face.

Hanging Staircases

Hanging staircases are prominent elements in Chavín architecture. Analysis of hanging staircases within the sequence, as well as the principles behind their placements, enables a

discussion of how these staircases functioned. Some archaeologists have proposed that staircases were built in front of the hanging staircases on the east face connecting the staircases to the ground (Rowe 1962: Figure 15; Kaufmann Doig and Gonzales 1993:Figura 11, Figura 13; Lumbreras 1993:61). No evidence exists for such staircases, however, as has been noted by other archaeologists (Burger 1992:177). An examination of when these staircases appear in the sequence, how they are placed relative to other features, and the forms they take suggests that these staircases were not entered from below, but rather were truly “hanging” staircases, designed to be entered only from the temple summit.

Hanging staircases are built in the NEA Phase (the East Face Gallery), the Expansion Stage (the East Face North Staircase on the east face of Building A, the Lower Portada Gallery on the south face of Building A, and the Marino Gonzalez Staircase on the east face of Building A), and the SA (the East Face South Staircase and the South Face Staircase, both on Building A). The South Face Staircase replaces the Lower Portada Gallery as the hanging staircase on the south face when the SA addition blocks the MA in which the Lower Portada Gallery exists. Whether or not the NEA also had hanging staircases on its south or west face is unknown, as these faces are blocked by later additions.

The analysis of the East Face Gallery sheds some light on the roles of these hanging staircases. The East Face Gallery is built in the NEA phase, with the monumental Escalinata double staircase just around the corner on the north face. Why build an additional staircase on the east face? The East Face Gallery’s location in such proximity to the Escalinata Gallery, as well as the fact that it is a hanging staircase, suggests it was used for something other than entering the temple.

Most of the hanging staircases are bent, meaning the upper flight descends parallel to the facade, then at a landing staircase bends and descends perpendicularly down to the façade. This bent form suggests that a person would be able to descend the staircase unseen until the final steps, then turn and emerge in front of people watching below. Alternatively, or perhaps

additionally, perhaps both the short height of the East Face Gallery entrance and the ledge at its doorway indicate that this doorway originally may have been used for the display of some object, such as sculptures, ritual objects, or even ancestral mummy bundles. It is possible that the use of the staircases changed over time in subsequent phases, or that different hanging staircases had different uses. However, the increased elevation of Lower Portada and SA South staircase, sitting 8.7m and 9.9 m above the base of the temple respectively, again casts doubt on the possibility that exterior staircases, for which no evidence remains, were built flush against the exterior façade. These patterns suggest that these hanging staircases were meant to be entered from above, or perhaps not at all.

Of the hanging staircases, only the Marino Gonzalez Staircase is neither centered nor bent; this may suggest its construction was constrained by some unknown factor or it was used differently from the other hanging staircases.

Architectural principles and the construction sequence

Architectural principles are a powerful tool for determining the construction sequence. As was demonstrated in earlier chapters, architectural principles such as centered staircases, stepped ceilings over staircases, lack of mensulas in staircases, and staircases connecting galleries built in different times, can help establish how the site was constructed, by helping to identify modifications, isolate phases, and determine their sequence.

How does the architecture at Chavín change over time? What are the implications of these changes for site use and labor investment over time?

Changes in construction

A shift occurred over the architectural sequence in the forms of the construction stages. The early phases of the sequence are characterized by high volume, high area constructions that

contain internal galleries that are elaborate in forms and features. The Expansion Stage epitomizes this mode of construction. These buildings, galleries, and their gallery patios were accessible primarily or perhaps exclusively via the Escalinata Gallery, suggesting that access to them was restricted.

In the Black and White phase, efforts switch from high-volume constructions with elaborate galleries to the construction of structures that contain less volume, cover more area, and contain elaborate, highly decorated, precisely executed, highly symmetrical surficial constructions that create an external visual display. The internal constructions are standardized and minimally elaborated. Emphasis is on the highly decorated exterior spaces. The use of the galleries continues, however, as indicated by the construction of new yet standardized galleries in the Black and White Stage, including the galleries in the Circular Plaza Atrium, and Outer Lanzón and Lower Laberintos in Building B. The gallery patios are covered and converted into galleries in this stage. Access to the temple buildings stays restricted. The Circular Plaza Atrium blocks the entrance to Escalinata and replaces it with the Circular Plaza Staircase as the primary entrance into the temple. The shift in emphasis from large buildings with elaborate galleries to large decorated spaces with standardized galleries, can be seen as a new element added to the architectural suite at Chavín.

Implications for understanding site use

The shift from the construction of volume to the construction of area suggests a change over time in how Chavín functioned. Prior to the Black and White Stage, the focus on galleries, small gallery patios outside their entrances, and their restricted access, suggests they were designed for individuals or small groups to use the space. The shift to the Black and White Stage, with its plazas, terraces, and flanking mounds with staircases ascending directly from ground level, likely represents a shift in emphasis to creating larger open spaces to accommodate more people. The design of the galleries for individuals and their restricted access have long been

contrasted with the construction of plazas and open spaces in analyses of Chavín, in terms of the transition from the smaller Old Temple with its small circular plaza, to the New Temple with its large square plaza (Moore 1996; Burger 1992) The architectural sequence presented here demonstrates that this shift was more drastic than previously believed, in that all the known plazas – the Plaza Mayor, the Plaza Menor, and the Circular Plaza – are built in the Black and White Stage, the final monumental stage. Furthermore, structures built in the Black and White Stage cover and fill the gallery patios, suggesting even less of an emphasis on activities focused on individuals or small groups using the galleries. The large plazas and terraces that appear in the Black and White Stage, in contrast, enable many more people to be accommodated at the site, perhaps in a role more as spectators than participants. While individual experiences in the galleries likely still were a significant component of the site’s function, the construction of large areas containing plazas and other surficial features represents the addition of an outward-focused component to site use. Early, the emphasis is on massive volume filled with elaborate internal spaces and small gallery patios for limited numbers of people. Late, the emphasis is on surficial external architecture – plazas, terraces, and low mounds connected by staircases – that contains standardized galleries, stylistically ties areas together, and can accommodate large numbers of people.

Implications for understanding labor investment across construction stages

Earlier studies considered the New Temple to be the largest construction period primarily because of its large area. Rowe (1962, 1967) postulated a significant increase in size in the final phase, or “New Temple”, and the Old Temple was viewed by Burger as a small, low labor construction (Burger 1992).

In contrast, the new sequence presented here indicates that labor investment likely is high early in the sequence as well, particularly when volume, labor, and area are considered together rather than just area. In particular, the Expansion Stage, early in the sequence, required a

large amount of labor, with its high-volume, high-area, stepped platform construction including internal galleries that are elaborate in forms and features, fine stonework, and the deconstruction and modification of the NEA east face and the northwest corner of the NEA. From the earliest phases, the construction at Chavín is monumental, requiring the transport of huge blocks and construction with them. From the earliest architecture known at the site, the NEA with the large Escalinata double staircase and its massive stonework, to the carved granite stonework decorating the surficial plazas and staircase of the Black and White Stage, the amount of labor required to create each phase is considerable. These patterns indicate that large amounts of labor were employed to construct the site early in the sequence, and suggest that the ability of leaders at Chavín to organize such labor also was high early as well as through the Black and White Stage.

Quantification of the volume, internal gallery volume, and area created in each phase would be an interesting future study. I would hypothesize that the construction of volume requires more labor than the construction of area. Additionally, I would hypothesize that a given volume of gallery space, formed by large wall stones and usually massive ceiling stones, requires more labor than the same volume of fill, comprised of dirt and small stones. A phase with a very high percentage of interior space volume therefore would be significantly more labor intensive to build than a phase or equivalent volume comprised solely of solid fill or largely of surficial features covering a wide area. This would suggest that the surficial external structures and standardized gallery forms of the Black and White Stage arguably are less labor intensive than the high-volume constructions, particularly those containing elaborate internal galleries. The amount and elaboration of interior space volume within a phase may positively correlate with the ability of the leaders at Chavín to command larger amounts of labor to build the temples

Architectural Forms and Chronology

When were the Circular Plaza and the U-shaped form incorporated into Chavín architecture?

In the Black and White Stage, formal coastal features are incorporated: the Circular Plaza, based on north coast traditions, and the formal U-shape temple with a prominent central building (Building A) and long, low flanking mounds (Late Building E and Building F), characteristic of the central coast (Williams 1985).

The smaller U-form of Buildings A, B, and C likely is in place in some form by the end of the Expansion Stage. Exactly at what phase the U-shaped form created by Buildings A, B, and C came into being is unclear. This is due primarily to the fact that the external walls of Building C are largely missing or buried by later constructions, and thus inhibit determining the presence of any external seams in the mound. It does appear that Building C and the four phases of Loco are complete before the Black and White Stage, due to the lack of standardized gallery forms in its phases. The U-form created by these buildings appears to have been less formal than the large, highly symmetrical U-form that was completed in the Black and White Stage.

Incorporation of other architectural forms: highland forms, coastal forms, and Chavín innovations

With this study, it is now possible to more clearly identify other architectural forms present at Chavín, as well as when they appear in the architectural sequence. Evidence suggests that antecedents of some of the architectural elements at Chavín lie in the local highland Kotosh-Mito culture of the surrounding area. In particular, the free-standing rectangular structures seen at Chavín, as exemplified by the Inner Lanzón Rectangle, resemble the rectangular stone chambers that have been identified as a key element of the Kotosh Religious Tradition by Burger and

Salazar-Burger (1985). Rectangular stone chambers are seen at highland sites belonging to this tradition, like Kotosh (Izumi and Sono 1963; Izumi and Terada 1972), and La Galgada (Grieder and Bueno Mendoza 1985; Grieder et al. 1988). The architecture at Chavín does appear to incorporate this and other features of Kotosh Religious Tradition, beginning in its earliest phases,

A number of similarities with La Galgada and Kotosh are present at Chavín. Many of these similarities exist between the galleries at Chavín and the rectangular chambers at these other two sites. For example, at La Galgada, the interior walls of the ceremonial chambers were covered with mud plaster and painted with white and black (Grieder and Bueno Mendoza 1985:96, Figure 3, Figure 4), similar to the plastered galleries at Chavín. Additionally, the large single mound of the NEA resembles the large singular mound of La Galgada in stonework construction and form, as a stand-alone building. The niches in the Alacenas gallery in the NEA, one of the earliest galleries at Chavín, resemble those in the ritual chambers at La Galgada (Grieder and Bueno Mendoza 1985:Figure 5, Figures 8-10) in that they are small, numerous, and placed close-together around the walls of the two gallery chambers.

The Inner Lanzón Chamber may find its antecedents in the Kotosh Religious Tradition, albeit with Chavín variations. The Inner Lanzón Rectangle strikingly resembles the many rectangular chambers at Kotosh, such as the Templo de las Manos Cruzadas (Izumi and Terada 1972: Figure 89, Color Plate 1), as well as the rectangular chamber in the south mound at La Galgada (Grieder et al. 1988: Figure 51) in shape as well as size. Floor vents are distinctive elements of the chambers in this tradition: vents are present in the Inner Lanzón Rectangle and the Inner Lanzón Chamber, albeit through the walls rather than under the floor. The central fire is also an important component of the chambers of the Kotosh Religious Tradition; as Grieder and Bueno Mendoza (1985:106) state, “within each chamber the position of authority, the focal point, was occupied by the fire and could not be claimed by any person.” In the Inner Lanzón Chamber, the central position is occupied by the Lanzón itself. One may speculate that in this case, the central fire may have been replaced or “claimed” by the Lanzón. Whether the Inner Lanzón

Rectangle was left open or perhaps covered with a wooden roof as in chambers at La Galgada is unresolved.

In the Loco Gallery at Chavín, the chambers in the Loco Rooms episode also resemble the chambers at La Galgada, although on a smaller scale. One feature in particular is striking: the column in Segment S that abuts the center of the back wall of the room and supports the ceiling is very similar to a pattern described by Grieder and Bueno Mendoza:

When a chamber was to be converted to a tomb the wooden roof was torn off and unworked boulders were brought in to build a massive column over the firepit (Fig 8). Two of the rectangular chambers had massive walls built down the center, leaving a narrow tomb on each side. Over this center column or wall crude stone beams were laid to the old chamber walls, and stone and earth were piled on top to serve as the base for a new chamber. A stone-lined tunnel or shaft was left from the top surface down to the tombs, and sometimes additional burials were added. In one unlooted tomb two flexed bundle burials had been set on top of two earlier extended burials. (1985:99)

Segment S and the four other small rectangular structures likely stood atop Low Building C at Chavín. No vents are currently visible within their walls that would have connected them to the outside, normally part of internal segments, suggesting they were small, freestanding structures, possibly open or possibly roofed, possibly with wood. The column suggests that at least Segment S could have been roofed with stone after its initial construction

Outside the galleries, other similarities exist.. The exterior stonework of La Galgada is similar to the rough exterior stonework at Chavín, consisting of large flat-faced stones interspersed with chinking, and apparently backed by stone and mud fill (Grieder et al. 1988:Figures 43-45). Primary staircases are centered and axial symmetry emerges in the final phases (Grieder and Bueno Mendoza 1985:105, 106, Figure 2, Figure 12); both of these characteristics, though certainly not exclusive to La Galgada or the other highland sites, are present at Chavín beginning with the earliest known phase, the NEA, and continuing through the sequence. A U-shaped structure is present atop the mound near the end of the sequence at La Galgada (Grieder and Bueno Mendoza 1985:106, Fig 12), suggesting La Galgada may have incorporated an example of the coastal form here. An early U-form may be formed by the early

Buildings B and possible early Building C along with the NEA; the structures arranged in a U-form at the top of the mound at La Galgada late in its sequence suggest an early U-form at Chavín may not be solely a coastal influence. La Galgada ranges in time from 2400-1900, spanning the late Preceramic Period and the early Initial Period (Grieder and Bueno Mendoza 1985:93).

While the NEA has some similarities to La Galgada, primarily in its stonework and the fact it is a separate building, the NEA and the B Platform share similarities with coastal preceramic architectural forms as well. Among the characteristics of Preceramic coastal architecture,

The mounds are free-standing and rectangular, or banked against hill slopes, forming rectangular terrace platforms. The inclined sides of the structure may be masonry faced and terraced. ... The formal focus of use is upon summit structures, including courts and rooms (some with wall niches or adobe friezes). (Moseley 1985:44)

These two early buildings at Chavín contains some characteristics of Preceramic coastal forms, as well as similarities to some characteristics seen at preceramic and Initial Period highland site of La Galgada.

The temple at Chavín, however, was not originally oriented approximately east, as it was in its final stages and as Initial Period and Early Horizon U-shaped temples on the coast were (Conklin 1985:144; Williams 1980). The NEA was originally oriented north. The shift to an east orientation occurs after the NEA, possibly beginning with the construction of the B Platform and the Inner Lanzón Rectangle, but more formalized during the Expansion Stage.

The addition of the Expansion Stage also sees the incorporation of more clearly coastal forms. This stage introduces a long set of rectangular stepped platforms, similar to those that are present on the coast in the third millennium B.C. (Moseley 1985:44), containing different levels and patios. By the end of the Expansion Stage, the U-shaped form of Buildings A, B, and C likely is in place. This is followed by a series of phases of construction of overlapping stepped platforms, filled in with block phases.

In the Black and White Stage, formal coastal features are incorporated: the Circular Plaza, based on north coast traditions, and the formal U-shape temple with a prominent central building (Building A) and long, low flanking mounds (Late Building E and Building F), characteristic of the central coast (Williams 1985). Freestanding rectangular structures continue to appear through the Black and White Stage, however. In Building A they appear as the north and south rectangular structures with standardized "H" internal forms, built on top of the building aligned with the Black and White Axis. In Building B, Gallery VIII above the Inner Lanzón Chamber and the WB-MB phase may also have been a rectangular structure, also with an internal "H" shape, prior to being incorporated into the EB-High B- CPA phase. The construction sequence at Chavín is thus one of transition as well as synthesis, beginning with local forms based in the Kotosh-Mito traditions, and transitioning to the incorporation of coastal forms that reach their most formal in the final monumental stage, while still incorporating aspects of the local forms.

What aspects of Chavín architecture are unique to Chavín? Do these aspects change over time?

Chavín architecture combines these forms to create a new manifestation of monumental architecture. This has been noted in other studies: “the Old and New Temples of Chavín bring together and integrate architectural forms that can be traced back in time to expressions in Preceramic monumental construction on the Pacific watershed” (Moseley 1985:48). The construction sequence presented here makes more clear when some of these antecedent forms were introduced. It also demonstrates that the galleries, one of the most characteristic and unique aspects of Chavín architecture, are present from the beginning of the sequence, in highly elaborate form, far more developed than at other sites containing gallery-like forms, such as La Galgada and Cerro Sechín. While variations on gallery-like structures are present at other sites, the galleries at Chavín are elaborated to an extent well beyond any forms seen at other sites. More

importantly, the mounds and stepped platforms are designed with galleries as integral features of their constructions. The stepped platform form of the Expansion Stage is formed around galleries, each step corresponding to one or more galleries. For example, Murcielagos and the upper portions of Upper Pasos Perdidos are integrated within the High NWA, while the two levels of the Upper Laberintos phase coincide with a step down beyond the platform adjacent to the High NWA. In contrast, the Circular Plaza likely is imported in the coastal form, elaborated with carved slabs, while the exterior stonework begins similar to La Galgada, but its coursing patterns and the quality of its stonework are elaborated over time. Throughout the sequence at Chavín, variations and innovations unique to the site are present. The highly developed gallery construction methods of early buildings suggests that some of this development was done in preceding periods in galleries within buildings or areas not revealed today, suggesting further time depth for the site.

What does the sequence suggest about Chavín ideology and how it may have changed over time?

Role of the Lanzón monolith

Archaeologists have postulated that the Lanzón monolith declined in importance over the site sequence, citing the supposed transition from the Old Temple to the New Temple as an indication of the diminished importance of the Lanzón monolith (Rowe 1962, Lumbreras 1977). The construction of the EB-High B-Circular Plaza Atrium Phase during the Black and White Stage suggests that the Lanzón monolith does not decline in use and importance over the temple's existence, but rather remains in use throughout the sequence and may even have gained importance during the Black and White Stage. The Circular Plaza and the Circular Plaza Staircase up the east face of Building B focus attention on the gallery within. Outer Lanzón maintains access to the Lanzón monolith in this new phase, and connects with Laberintos, transforming the two galleries into one large gallery complex. The galleries in the upper layer of the building, the

Laberintos Alcove and Gallery VIII, are added at this time as well, with the Alcove serving as another entrance to Laberintos, and possibly connecting with Gallery VIII, creating an even more integrated gallery complex throughout Building B. The integrated constructions here late in the sequence and the high amounts of labor that must have gone into their construction, including the deconstruction of the north wall of the NEA to accommodate the Laberintos Alcove, indicate that the Lanzón monolith and the surrounding building were still important in the latest phases of the temple.

Tenon heads

The earliest indication of the tenon heads appears in the Expansion Stage, in the form of similar stonework on the tenon head course continuing on to the MA and stopping at the point in which a tenon head would be properly spaced. Whether or not they appeared earlier than this stage is unclear. Decorative features resembling the tenon head and cornice combination of the SA exist on Early Building E, built in the East Area Pre-Black and White Phase.

Alignments of Internal and External Features

A set of interesting relationships exists between internal and external features; delving into these relationships reveals architectural patterns that may illuminate something about ideology at Chavín. While conclusions based on these patterns are speculative, the patterns are derived from the precise three-dimensional survey of the temple architecture.

The first relationship considered lies between the columns in the Columnas-Vigas gallery and the columns of the Black and White Portal in front of the east face of Building A. The two columns of the Black and White Portal support a decorated cornice that spans them like a doorway lintel. These columns originally were accompanied by another pair of columns that stood farther to the east; fragments of these columns were found on near the Black and White Staircase. In total, then, it appears that four columns stood in or near the Black and White Portal,

and that at least the west pair supported a decorated lintel. The columns and lintel of the Black and White Portal are centered on the Black and White Axis. The Columnas-Vigas gallery sits directly west of the Black and White Portal. In this gallery stand four structural columns, the west pair of which supports a large lintel that spans the two columns. These columns stand in the portion of the gallery that originally was an open patio, the Columnas Patio. The Columnas Patio is centered north-south in Building A. It seems unlikely that these crude, structural columns stood here when the patio was open. Rather, they appear to have been added when the North Columnas-Vigas gallery phase was built to cover the Columnas Patio.

The Columnas Patio was covered during the Black and White Stage, likely due to the very fact that it was centered in Building A, so that the new Black and White Axis could be established with the construction of the Black and White Portal. I speculate that the Columnas Patio originally may have contained four columns, the west pair perhaps spanned by a lintel, as part of a highly sacred area within the patio, centered at the summit of Building A. When the gallery was covered, structural columns were built in the place of the columns, to symbolically represent them while providing support to the new ceiling. Columns and a lintel were then placed in front of the east face of Building A, perhaps as an attempt to transfer some of the meaning of those original columns from the Columnas Patio to a more visible focal point, now aligned to the Black and White Axis. A further speculation is that the original columns and lintel from the Columnas Patio may in fact be the columns and lintel that stand today in the Black and White Portal on the east face, along with their broken counterparts. This could explain why the avian figures on these columns and lintel, which are featured in such a prominent place on the east face, are so finely and shallowly carved that they are visible only from up-close: perhaps they originally were intended for a more intimate setting, that of a small gallery patio high on the summit of the temple.

Another set of alignments exists between the elevation of rows of pegs within the galleries and exterior decorative features. First, as described in earlier chapters, the pegs in the

Inner Lanzón Chamber align with the belt of the Lanzón monolith itself – a feline figure accompanied by snakes – as well as with the surface of the Lanzón Patio connecting the entrances to Middle Lanzón and Upper Laberintos, and the level of the CFT (coarse-to-fine transition) on the east, south, and west faces of Building A. Second, the pegs in Upper Laberintos align with the tenon-head course (THC) of human-feline heads, higher than the level of the Lanzón pegs. Third, above the tenon heads course sit the pegs in Cautivos. External walls no longer exist at the height of the Cautivos pegs, prohibiting examination of possible alignments with external features. They do align, however, with the lintel spanning the support columns in North Columnas-Vigas. They were constructed at the same time as the Columnas Patio, and thus could have aligned with the avian lintel hypothesized here to have spanned the hypothetical original columns in the Columnas Patio.

Another possibility regarding the alignment of the Cautivos pegs is based on the evidence, presented in Level 1 analysis, that during the construction of the Cautivos Gallery, the south wall of the High NWA was deconstructed down to the top of the course below where the pegs in Cautivos now sit, and that the pegs were then added, the wall rebuilt above them, and the Cautivos Gallery constructed along this wall. I hypothesize that these pegs were placed to mark the level of a decorative feature that originally existed externally at this level of the High NWA, and that this feature likely continued externally on the other faces of the High NWA after Cautivos was constructed; in this case, the exterior decorative features were removed and replaced with interior pegs to mark their former location. The original exterior decorative features on this wall would have been associated with the entrance to the Murcielagos Gallery, which is centered in this wall.

Based on the observed alignment of these features, I hypothesize that the architecture at Chavín was divided into three levels, and that these three divisions existed externally as well as inside the galleries, marked by these pegs. The highest level corresponded with the Columnas Patio at the top of the temple, possibly symbolically associated with the sky and the feline-avian

figures of the hypothetical lintel spanning the original columns, and possibly associated with the red plaster evident in the seam Col-E-2 marking the outer wall of the Columnas Patio. The central level corresponded with the tenon heads, with their feline-human features possibly associated with the earth. The lower level corresponded with the white-plastered Lanzón Patio and the Lanzón monolith itself, associated with a feline-snake link with the underworld. Furthermore, right at this level between the earth and the underworld, at a level broadcast across the stonework of the whole exterior at the level of the course-to-fine transition and made clear to all who visit the site, sits the Lanzón monolith with his earthly feline form and his underworldly serpent entourage, a god mediating between the earth and the underworld, with hands pointing to the two worlds, asking the visitor to make a choice between worlds. While this architectural division does correspond with the Andean tripartite division of the cosmos into heaven-avian, earth-feline, and underworld-snake associations, this proposition is clearly hypothetical. Nonetheless, the alignments between interior and exterior features described here do exist, and should stimulate new ways of thinking about Chavín sculpture, architecture, site use, ritual, cultural meaning, and ideology, as well as their development over time.

For example, if an external decorative feature did exist at this level above the Murcielagos Gallery entrance, then each of the three alignments described above was constructed at the same time, in the Expansion Stage. Of further interest is the fact that each of the three alignments sits directly above a centered external opening to a gallery or hanging staircase of the Expansion Stage (see Figures 7.1-A - 7.3-A). From top to bottom, Alignment 1, consisting of the Cautivos Pegs, sits one course directly above the entrance to Murcielagos. Alignment 2, the tenon head course and the Upper Laberintos pegs, sits directly above the entrance to Lower Portada, as described in Levels 2-3 Analysis, at the highest A course still visible at the abutment of Lower Doble Mensula to the south face of the MA. Alignment 3 -- at the level of the Inner Lanzón Chamber pegs, the feline-head belt of the Lanzón monolith, the Lanzón Patio surface and the

entrances to Middle Lanzón and Upper Laberintos, and the course-to-fine transition -- sits one course above the entrance to the East Face Gallery on the east face of Building A.

Based on these relationships of the external-internal feature alignments with centered doorways at different levels, I hypothesize that these three alignments likely were symbolically related to the architectural levels in which they sat and to a system of transit and perhaps mediation between the different levels. For example, from the doorway of Murcielagos, at the highest level of the Expansion Stage, the High NWA, a person could emerge from the level marked by Alignment 1, walk along the top surface of the MA, NEA, or NWA, and descend to any of the levels below. Through the Lower Portada hanging staircase on the south face, the person could descend to the level below Alignment 2, visible at the centered opening of this hanging staircase to people below. Through the East Face Gallery, also a hanging staircase, the person could descend to the level below Alignment 3 at the east face. Through the Escalinata Staircase, the person could descend to ground level on the north face. Alternatively, when standing on the surface of the Lanzón Patio, the person would be at the boundary between levels, perhaps preparing to visit the Lanzón monolith, who spans Alignment 3, crossing into two levels. The remains of colored plaster in the gallery patios suggests that the external surfaces of the temple may have been plastered, possibly creating even more visual distinctions between levels. Stonework alternates between the three levels as well, with rough stonework at the level of the Murcielagos entrance and below the CFT, and fine stonework in the middle level.

Clearly much work remains to be done investigating Chavín architecture and its implications for understanding symbolic meaning and site use, as well as how they changed over time. The above discussions highlight the likelihood that the architecture and the way it was used held richly symbolic cultural meaning. By understanding how that architecture changed, we can study how site use and ideology at Chavín may have changed along with it.

Comparison of the Construction Sequence to Other Sequences for Chavín

Towards an absolute chronology for Chavín architecture: comparisons of the architectural sequence to radiocarbon dates from the monumental center

A link between the Chavín architectural sequence and radiocarbon dates comes from the Ofrendas Gallery, where approximately 800 ceramic vessels and other artifacts were found in situ with remains of plant and animals, as well as human bones (Lumbreras and Amat 1965-1966; Lumbreras 1993). In his analysis of the Ofrendas Gallery, Lumbreras concludes that the Circular Plaza Atrium, the Circular Plaza, and its surrounding galleries including Ofrendas, Campamento, and Caracolas, were built in one phase as a functional complex (Lumbreras 1993:310-311), a conclusion supported by the results presented here. Based on evidence of the structure of the entrance of Ofrendas, which does not accommodate access easily, and on the remains of mortar on the entrance walls showing indentations of large beams that completely covered the gallery entrance, Lumbreras concludes that Ofrendas was designed and constructed to be sealed (Lumbreras 1993:69, 312). The placement of the artifacts and the nature of their grouping suggests they were placed to be sealed and were deposited over a very short time period, rather than continually accessed over a long period. He concludes that the vessels and other contents were deposited in a single episode before being sealed in the gallery. He proposes that the deposit was a ritual offering, possibly as part of an initiation ritual for the structurally associated Circular Plaza and the surrounding atrium (Lumbreras 1993:311-312, 315). This evidence suggests that the Ofrendas Gallery was sealed soon after it was constructed and thus that the deposit essentially is contemporaneous with its completion.

The architectural sequence presented in the previous chapter demonstrates that the Circular Plaza Atrium and its associated structures, including the Ofrendas Gallery, were built late in the sequence, in the Black and White Stage. Given that the Ofrendas offering was in fact deposited at the time of the completion of the construction of the Circular Plaza Atrium, as

concluded by Lumbreras and supported here, the deposit can be associated with the construction of not only the Circular Plaza Atrium but also the rest of the Black and White Stage. The dates from the Ofrendas Gallery offering therefore serve as dates for the completion of the Black and White Stage. An argument that the gallery was not closed after construction but remained open over a long period of time, would push the dates and ceramics associated with the deposit to after the construction of the Black and White Stage was completed, placing the deposit even later in the construction sequence.

Because the Black and White Stage is the last phase of monumental construction at Chavín, the construction of the buildings of the monumental center at Chavín likely was completed around the time of the Ofrendas Gallery deposit. The two radiocarbon samples associated with the remains of the Ofrendas Gallery deposit are GX-1128, dating to 2700 \pm 85 B.P. (750 B.C. uncalibrated) and TK-18, dating to 3050 \pm 120 B.P. (1100 B.C. uncalibrated) (Lumbreras 1993:418) (Tables 7.1 and 7.2). Burger (1992:233) lists the calibrated date for GX-1128 as 838 B.C. The construction of the Ofrendas Gallery and the rest of the Black and White Stage thus likely occurred at or before these dates of 1100 B.C. and 750 B.C., likely closer to 750 B.C.

Radiocarbon samples collected by Rick from strategic excavations at exterior seams on Building A are consistent with this correlation of the architectural sequence with radiocarbon dates. Two samples from near the base of the A-E-1 seam return dates of 2640 \pm 55 B.P. (690 B.C.) and 2695 \pm 55 B.P. (745 B.C.) (Rick and Kembel 2000). This excavation dug through the Black and White Zócalo, which was built against the east face of Building A during the Black and White Stage, blocking the base of the seam. These samples therefore likely date the construction of this zócalo and are associated with the construction of the Black and White Stage. When compared with the dates of the Ofrendas Gallery deposit, also from the Black and White Stage, these dates are consistent with the 750 B.C. date from the GX-1128 sample from the Ofrendas Gallery deposit, but are not consistent with the 1100 B. C. date of the TK-18 sample. Like the

Ofrendas samples, these samples are taken from contexts directly associated with architectural constructions that are chronologically distinct. The closed context of the zócalo construction in particular associates these dates with the Black and White Stage. The similarity of the returned dates to each other and to the Ofrendas GX-1128 sample lends further confidence to these dates.

Another sample was collected by Rick in excavations at the A-W-1 seam of Building A. It was taken from layers near the base of the seam, but above the foundation of the SA Platform. These layers are an early part of the support construction fill built up against the west face clearly after it had reached its full south extent. It likely was built up after the construction of the Black and White Stage of the temple was complete, as suggested by the following observations. First, Building A was an integral part of this stage and likely was maintained free of surrounding fill during times of use. Second, the stabilizing wall on the Plaza Menor Terrace and the megalithic stabilizing wall on the west face of Building C post-date the construction of the Black and White Stage. The formality of these support constructions suggest they were built before the support construction of the south end of Building A, which is not a formal coursed wall, but rather is support fill of boulders, smaller stones, and dirt, placed against the wall. The sample taken from this excavation dates to 2455 +/-55 B.P. (505 B.C.) (Rick and Kembel 2000). This is consistent with the dates from the Ofrendas Gallery and the Black and White Zócalo, both of which are associated with the Black and White Stage: the fill on the west face very likely followed the Black and White Stage and the full construction of the temple, and its date correspondingly follows those from the Ofrendas Gallery and the Black and White Zócalo.

Other dated samples from the ceremonial center come from deposition levels in the Circular Plaza Atrium that follow the construction of the Circular Plaza Atrium structures. They therefore follow the Black and White Stage, suggesting they were deposited after monumental construction at the site was complete. A radiocarbon sample from Level H of the Circular Plaza Atrium, the level sitting directly above the Circular Plaza floor and parts of the top of the Circular Plaza Atrium platform surface (Lumbreras 1977; 1993: 66, 315), dates to 2380 +/-70 (430 B.C.),

sample HAR-1105 (Lumbreras 1993:417-418); it is associated with Chavín ceramics (Lumbreras 1977:10, Fig 8-14) and assigned to the Janabarriu phase (Lumbreras 1993:417-418). Samples collected by Rick from Level H returned dates of 445 B.C. and 310 B.C. (Rick and Kembel 2000). These samples suggest that fill-in of the Circular Plaza and the Circular Plaza Atrium was already occurring by around 430 BC.

Level H in the Circular Plaza Atrium was comprised largely of plaster that had fallen from the faces of the surrounding structures (Lumbreras 1977:9). Refuse was found mixed in this layer. No evidence of living structures were found, although only 10-15% of the layer's total area was excavated. Level H was sealed by rubble fallen from the temple, and sits on top of the plaza floor and terrace. A wall was uncovered in association with Level H abutting the main body of the temple, as if it had been a support wall against this façade. Lumbreras writes:

Esta tierra se encuentra mezclada, en la capa H, con cerámica rota, huesos rotos de animales, instrumentos y desechos de piedra además de algunas piedras pequeñas (guijarros); esto indica que se trate de una capa de basura, lo que naturalmente no congenia con el carácter del templo, el cuidado de sus pisos, etc. Por eso, suponemos que la capa H es de un período de abandono de esta parte del centro ceremonial; período durante el cual el enlucido de los muros se fué cayendo y la gente arrojó desechos de comida y vajilla rota. [...] No hemos encontrado ningún rastro de vivienda en asociación con la capa H, pero podría incluso esperarse un tal uso; en realidad eso lo sabremos sólo cuando hayamos excavado una área mayor de la capa H, pues sólo se ha excavado un 10-15% de su área total. [...] La capa H está sellada por el derrumbe del templo y está encima del piso del mismo. En asociación con ella hay restos de un muro pegado a la parte baja del cuerpo central, como si fuera un sostén del dicho frontis; pero como de esta asociación sólo conocemos unos dos metros, será mejor esperar más información para establecer cualquier deducción. (Lumbreras 1977:10)

This soil is found in level H mixed with broken ceramic, broken animal bones, stone instruments and fragments, in addition to some pebbles; this points to it having been a layer of refuse, which naturally is not compatible with the nature of the temple, the care of its floors, etc. Because of this, we assume that level H corresponds to a period of neglect of this section of the ceremonial center, during which period the plaster fell off the walls and the people tossed in food waste and broken dishes. [...] We have not found any trace of habitation associated with level H, but such usage is possible; we will know this for certain only when we have excavated a larger area of level H, since only 10-15% of its total area has been excavated. [...] Level H is sealed by collapse from the temple and lies over the temple floor. Associated with the layer are remains of a wall attached to the lower part of the central structure, as if it were a support of the aforementioned façade. However, since we only have evidence of two meters of this association, it is preferable to await more information before establishing any conclusion. (translation mine)

Additionally, Lumbreras states that excavations of the Circular Plaza Atrium found

la "plaza circular" y un conjunto de elementos de diagnosis del período de colapso del viejo templo. Las capas G y H cubrían las escalinatas, la plaza y la plataforma Chavín; la primera capa es la evidencia del derrumbe, penetrada con rellenos posteriores y restos de basura de los ocupantes post-Chavín; la capa H es del período de decrepitud de Chavín, cuando por alguna causa se descuidaron la limpieza y pulcritud de los recintos sagrados y se dejó desechos dispersos encima del atrio del Lanzón, que en este tiempo y había pasado a ser lateral y secundario. (Lumbreras 1993:65)

the circular plaza and a group of elements from the period of the collapse of the old temple. Levels G and H covered the flight of steps, the plaza and the Chavín platform; the first level contains evidence of the collapse, penetrated by later fills and refuse from the post-Chavín occupants. Level H is from Chavín's period of decrepitude, when for some reason the cleanliness and neatness of the sacred enclosures were neglected and refuse was left scattered over the Lanzón atrium, which at this time had already become marginal and secondary. (translation mine)

For these reasons, this Layer H is interpreted as representing the abandonment of the Circular Plaza Atrium.

As alluded to at the end of the above quote, Lumbreras hypothesized that this meant this Layer H corresponded with the use of the New Temple and a drastically diminished importance of the gods of the Old Temple (ie the Lanzón) and the diminished use of the Old Temple itself:

Proponemos la hipótesis de que esta basura – más bien rala – es contemporánea con la ocupación más tardía de Chavín, con la época de uso del Templo Nuevo, cuando se había perdido la importancia de los dioses del viejo templo. El atrio en esta época pudo ser una suerte de "anexo" de la pirámide mayor, con poca o ninguna significación para el culto. (Lumbreras 1977:10)

We propose the hypothesis that this rather sparse refuse is contemporaneous with the final occupation of Chavín, the period of use of the New Temple, when the importance of the gods of the old temple had been lost. In this period, the atrium could have been a sort of "annex" of the larger pyramid, with little or no meaning for the cult. (translation mine)

The construction sequence presented here contradicts this interpretation. It demonstrates not only that the Circular Plaza itself is part of the final construction stage at the site, but also that the construction of the EB-High B-Circular Plaza Atrium phase and its galleries likely indicated the continued, if not increased, importance of the Lanzón. The possible correspondence of the

coarse-to-fine stonework transition as an indicator of the Lanzón across the exterior faces of the temple may correspond with the continued importance of the Lanzón as well. From this it can be concluded that the abandonment and collapse seen in the Circular Plaza Atrium likely extended to the rest of the temple. The construction of support walls and fill after the Black and White Stage corresponds with this interpretation, and is consistent with the presence of the support wall reported above by (Lumbreras 1977:10) against the façade of the temple and associated with the fallen plaster and refuse of Level H.

Considered together, the correspondence of the architectural sequence with radiocarbon samples associated with the architecture suggests that the final monumental construction stage of the monumental center at Chavín was completed by around 750 B.C. It also suggests that by about 500 B.C., the site had undergone a series of efforts to support and stabilize walls. The layers filling in the Circular Plaza suggest that by the mid-400s B.C., the Chavín temple complex was in disuse, was physically collapsing, and no longer functioned as it had during the preceding periods of monumental construction.

Relationships of the architectural sequence to the ceramic sequence

Both Burger and Lumbreras have proposed relationships between their ceramic sequences, radiocarbon dates, and the earlier three-phase architectural sequence outlined by Rowe (1967). Burger proposes that the first building phase of this earlier sequence corresponds with the Urabarriu phase of his chronology (850-460 B.C.), the first addition with the Chakinani phase (460-390 B.C.), and the second addition with the Janabarriu phase (390-200 B.C.) (Burger 1984:229-245; 1995:165). Lumbreras suggests a similar relationship of architecture to pottery phases, but associates the Old Temple with the Urabarriu and Ofrendas phases of his chronology (1200-600 B.C.), and the New Temple with the Chakinani and Janabarriu phases (600-200 B.C.)

(Lumbreras 1989:23). Burger states that the "Urabarriu ceramics pre-date or are contemporary with the earliest pottery of the Ofrendas Gallery" (Burger 1984:230).

The architectural association of the Ofrendas Gallery in the Black and White Stage places the Ofrendas ceramic phase in the Black and White Stage as well (at the earliest), very late in the architectural sequence. This suggests that the Urabarriu ceramic phase is associated with the Chavín construction stages prior to and perhaps including the Black and White Stage, and that the Chakinani and Janabarriu ceramic phases are associated with the site after the Black and White Stage. This is consistent with the excavation, described above, by Lumbreras of Capa H of the Circular Plaza Atrium, the level sitting directly above the Circular Plaza floor and parts of the top of the Circular Plaza Terrace surface (Lumbreras 1977; 1993:66, 315), in which he found Janabarriu ceramics associated with the HAR-1105 radiocarbon sample dating to 2380±70 (430 B.C.) (Lumbreras 1977:10, Fig 8-14; Lumbreras 1993:417-418). This suggests that the Chakinani and Janabarriu phases are associated with the center after its monumental construction has been completed and the site has declined; they first appear in the layers of disuse and physical collapse of the Circular Plaza Atrium. The construction of the Circular Plaza Atrium is associated with the Ofrendas Ceramic phase. Thus, while the associations of the ceramic phases with the architecture postulated by Lumbreras and Burger are superseded by this reevaluation, the dates of the ceramic phases generally stay the same. Urabarriu and Ofrendas generally pre-date 500 B.C. and are associated with monumental construction at Chavín, while Chakinani and Janabarriu generally post-date 500 B.C. and are associated with Chavín's physical collapse, decline, and disuse.

Relationships of the architectural sequence to the art sequence

Rowe's (1962, 1967) art sequence is directly associated with the architecture at Chavín in two of the four art phases. The primary anchor point for the sequence is the sculptures of the Black and White Portal, comprised of the two feline-avian figures on the columns and the avian

figures on the cornice spanning them. These were defined by Rowe as Phase D. Phase AB is also anchored in the architecture, as it includes the Lanzón from the Inner Lanzón Chamber. It also includes feline cornice blocks from Building A, such as the one currently in place on the west face of its the southwest corner (Rowe 1962:12).

The two anchor points maintain their same relationship to each other in the architectural sequence presented here, with the Lanzón built early, by the WB-MB phase of the Expansion Stage, and the Black and White Portal built late, in the Black and White Stage. The revised, more detailed architectural sequence presented here provides another anchor point for the sequence: the Circular Plaza Atrium. Because the architectural sequence indicates that the Circular Plaza Atrium and associated structures are built in the same phase as the Black and White Portal, the Circular Plaza sculptures should be in the same phase as the Black and White Portal sculptures – Phase D -- assuming the sculptures were carved at the time the plaza was constructed and were not reused from an earlier structure. This anchoring of the Circular Plaza sculptures in the architectural sequence provides more data with which to examine art styles at Chavín. If, however, the hypothesis that the Black and White Portal carvings may have originally stood up in the Columnas Patio proves correct, the Black and White Portal carvings would precede the Black and White Stage and thus the Circular Plaza sculptures could be argued to belong to a later phase, possibly a Phase E, subdividing Phase EF. This hypothesis can be studied in future analyses.

Discussions of Chavín art that followed Rowe (1962, 1967) have tried to integrate the in-situ artwork from the Circular Plaza, which was excavated by Lumbreras (1977), into Rowe's stylistic sequence. These studies have worked with the idea that the Circular Plaza was built as part of the Old Temple (Roe 1983:3; Burger 1992:149; Bischoff 1994). They therefore propose that the Circular Plaza artwork be viewed as Phase B of Rowe's sequence, dividing his original Phase AB. The architectural sequence presented here indicates the Circular Plaza was not built close in the sequence to the Lanzón, and that in fact they are widely separated in time, located at

opposite ends of the architectural sequence. The assignment of the Circular Plaza artwork (as well as the Ofrendas ceramics) to Phase B based on these postulated architectural associations is therefore invalid.

The correlations of the architectural sequence with the radiocarbon dates suggest that the Phase D Chavín art phase identified by Rowe likely dates around 750 B.C. and that Phase AB likely dates significantly earlier.

Burger (1984:244-245) postulated that the few examples of Phase D iconography on Janabarriu ceramics represented a chronological link between Janabarriu ceramics and the New Temple, the construction phase with which Phase D sculpture was associated (Rowe 1962, 1967). These were the primary link between the ceramic sequence and the New Temple (Table 7.3). The revised construction sequence demonstrates that the Phase D sculptures are indeed associated with the final monumental construction stage at Chavín, but that they are not associated chronologically with Janabarriu ceramics, predating them by approximately 360 years (dating the end of the Black and White Stage to 750 B.C. and the beginning of Janabarriu ceramics to Burger's proposed date of 390 B.C.) (Table 7.4). Instead these examples of Phase D iconography on Janabarriu ceramics as well as on gold objects (and perhaps textiles) from the late Early Horizon, may represent the beginning of archaistic imitation of Chavín art, defined by Rowe (1971:101) as "the direct imitation by later craftsmen of objects decorated in the Chavín style". This is consistent with Burger's statement (1984:245) that Janabarriu ceramics contain many examples of other iconography that does not relate to the sculptural sequence, decorations that do not relate to the sculptural style, and features considered by Roe (1974:14) to be earlier than Phase D.

Rowe's statements regarding the reuse and placement of these cornices and the tenon heads is particularly interesting in light of the architectural sequence presented here. He states,

We cannot use the sequence of additions to the old south wing to establish the order in which the cornices and tenon heads of this part of the structure were carved, because there is evidence suggesting that older sculptures were reused when a new

addition was built, and that damaged slabs in the older parts of the temple were replaced long after the original date of construction. The evidence is stylistic; some of the cornice blocks found by the walls of the third addition are almost identical in style with the earliest ones from the old south wing, while the most advanced style cornice slab in the whole temple was found near a much earlier one at the foot of the wall of the old south wing. (Rowe 1962:9)

The stylistic evidence that older sculptures were reused in additions is consistent with the architectural sequence. A proposal on how and why this was done, based on the architectural sequence, is as follows. When later phases were abutted against earlier phases, the sculptures from the walls that were to be covered by the addition may have been removed and transferred to the new structure. For example, in the MA phase, the level of the tenon head course sits directly at the highest course visible in the seam between Lower Doble Mensula and the Lower Portada, as shown in Levels 2-3 analysis. If tenon heads existed during the MA, as suggested by the tenon head course that continues from the SA on to the remains of the MA west wall, as well as by the alignment of the Upper Laberintos pegs, built at the same time as the MA, with the tenon head layer, these tenon heads as well as any cornices on this face could have been removed and reused on the new structure. Such a process may extend back to the earliest additions, removing any sculptures from the south and west faces of the NEA and placing them on to the NWA-High NWA-MA-SA Platform of the Expansion Stage. If any of the original NEA sculptures were moved to the south face of the MA, they could have been moved again to the SA. This may explain how and why a Phase AB sculpture, such as the cornice on the southwest corner of the SA may have been moved to a later building phase. Similarly, the discovery Rowe reports of a cornice slab with the most advanced style next to a much earlier one near the base of old south wing (the NEA) could be an example of replacement of an earlier slab due to damage or perhaps to “update” or “retrofit” this area to correspond with the Black and White Stage structures near this area, such as the Circular Plaza Atrium or the Black and White Portal.

Relationships of the architectural sequence to surrounding occupations

Through excavation outside the monumental center, including in the modern-day town, and surface explorations in and around the monumental center, Burger (1984) was able to study occupation patterns at Chavín. Urabarru-phase occupations were located principally in the Temple area (Burger 1984:229), and were also found in a small adjacent area long the north shore of the Rio Huachecsa, an area of occupation 0.5km to the north, and at an Urabarru-phase wall of megalithic boulders spanning the valley floor east-west, near the north edge of the modern-day town (Burger 1984:221-231; Map 2). Burger postulates that this wall helped to regulate trade and access to the monumental center (Burger 1984:224-226). He estimates a population of no more than a few hundred people lived in these areas in the Urabarru phase (Burger 1984:247). In the subsequent short-lived Chakinani phase, the megalithic wall and northern area were abandoned and the population around the monumental center increased: “There was a major change in settlement pattern in Chavín after the Urabarru phase. The northern or lower barrio was abandoned, and the occupation became concentrated around the Temple area on both sides of the Huachecsa” (Burger 1984:231; Map 3). The short-lived Chakinani occupation “was centered about the Temple precinct, with inhabitants living in the area immediately surrounding the Temple and in the zone closest to the Temple on the north side of the Huachecsa” (Burger 1984:233). Population increased, likely not exceeding 1000 people (Burger 1984:247). In the Janabarru phase, the megalithic wall remains abandoned and the area of the occupation, centered around the Temple, increases to approximately four times that of the Urabarru-phase occupation and three times that of Chakinani-phase occupation (Burger 1984:235; Map 4). Estimated population increases to between 2000 and 3000 (Burger 1984:247).

The dates of these occupations correspond with the dates of their respective ceramic phases. Burger hypothesizes that they correspond with Rowe’s proposed temple construction phases: the Urabarru occupation (850-460 B.C.) with the construction of the Old Temple, the

Chakinani occupation (460-390 B.C.) with the construction of the first addition, and the Janabarriu occupation (390-200 B.C.) with the construction of the New Temple (Burger 1984:229-245, 277; 1992:165). Burger has postulated that the movement of population towards the monumental center and away from the megalithic north wall during the Chakinani Phase, and increased growth during the Janabarriu Phase, may have been due to increased power, prestige, and centralization of the leadership of the monumental center along with greater economic opportunities that the center provided (Burger 1984:233-234; 1992:165).

The completion of monumental construction at Chavín around 750 B.C. and apparent physical destabilization by around 500 B.C., followed by evidence of physical collapse, disuse, and changes in the nature of its function, suggests that interpretations of these populations patterns need to be reconsidered. The radiocarbon evidence suggests that the Urabarriu occupation corresponded with the construction and use of the monumental center, while the Chakinani and Janabarriu occupations corresponded with the period after the site was abandoned. In this case, the abandonment of the Urabarriu-phase megalithic wall north of the monumental center would correspond with the disuse of the temple and any corresponding need to maintain the wall. The move of population towards the monumental center and the drastic increase of this population in the Chakinani and Janabarriu phases would represent the influx of people from the surrounding area to settle in and around the monumental center. This corresponds with the presence of Janabarriu ceramics in Level H directly above the floor of the Circular Plaza, associated with physical collapse of the Circular Plaza Atrium (Lumbreras 1977, 1993), which was built in the last phase of monumental construction. It also corresponds with the report by Burger of Janabarriu domestic structures built atop the large terrace platforms currently largely buried in the fields west of the monumental center. He states,

In some cases, religious structures were placed on top of the terraces, but elsewhere typical domestic structures were built on them. For example, Hernán Amat (personal communication) excavated one of the western terraces closest to the temple and discovered what appear to be two Janabarriu domestic structures on it. Below the houses and within the platform were galleries and a ventilation system. (Burger 1984:242)

This report suggests that these Janabarriu domestic structures could have been built well after the completion of these monumental terraces.

The very limited Urabarriu occupation of the area surrounding the center, the north megalithic wall, and the well-reported presence of galleries under the town and the north megalithic wall, suggest that occupation of the area around the monumental center was highly restricted during the Urabarriu phase. It may have been a sacred precinct in which settlement was largely restricted. The megalithic north wall may have served to demarcate the north edge of this restricted area, perhaps in addition to limiting trade flow.

The influx of people in the subsequent Chakinani and Janabarriu phases as well as the abandonment of the north megalithic wall suggest that such a restriction would have ceased with the collapse of the temple, and that people from the surrounding area gradually moved into the monumental center and the once-restricted area, desirably located on the valley floor near the confluence of two rivers. Rather than indicating an increased integration of populations with the monumental center, therefore, this increase in occupation size appears to correspond with an influx of population to occupy the temple area and surrounding valley floor after the temple's decline and physical collapse.

It is clear that the population that built the monumental center was never located solely in the valley floor around the temple:

The resident population in Chavín de Huántar would never have been large enough to supply the manpower to construct the Temple and maintain the specialists concerned with it (priests, sculptors, etc.). The scale and complexity of the Temple imply the existence of a large supporting population. At least part of the labor and agricultural surplus must have been drawn from contemporary hamlets and villages in the vicinity of Chavín de Huántar. (Burger 1984:248).

Burger reports that at the three villages he studied that were located several hundred meters above the valley floor, Urabarriu ceramics were found on their surfaces and therefore indicate these sites likely were occupied during the Urabarriu phase (Burger 1984:248). He states that sherd scatters in other small valley floor communities suggest they were “coeval with

the Janabarriu occupation of Chavín” (Burger 1984:249). These examples may represent population movement from higher areas in the Urabarriu phase (corresponding with the construction of the temple) to the valley floor in Janabarriu phase following the termination of construction and the collapse of the site.

Implications for understanding Chavín, its relationships with other sites, and the Chavín horizon

What are the implications of the architectural sequence for understanding Chavín as a site as well as its relationships with other sites? Earlier studies postulated that the final and largest building phase at Chavín in the architectural sequence proposed by Rowe (1962, 1967) corresponded with the peak of Chavín’s influence in other areas during the Chavín horizon, which Burger has proposed dates to approximately 490-200 B.C. (see Burger 1993:55). The dating of the construction of the final monumental stage, the Black and White Stage, to approximately 750 B.C., followed by destabilization and physical collapse around the fifth century B.C., suggests that both the site of Chavín and its relationships with other sites need to be reevaluated.

Changes at Chavín

Following the termination of monumental construction, the function of the monumental center at Chavín underwent a significant change. As mentioned above, the Circular Plaza Atrium, including the Circular Plaza, was built in the last monumental construction stage at Chavín, with the Ofrendas ceramics deposits near the end of the construction of the Atrium. The remains of collapse above the Circular Plaza floor contained Janabarriu ceramics. Above this, a long sequence of post-Chavín domestic structures was built within the Circular Plaza Atrium (Lumbreras 1977).

The Plaza Mayor and part of the East Area apparently remain open possibly for some ritual activity. Offerings deposited in the Janabarriu period (Lumbreras 1970: 49; Burger 1984:245) and later periods, including the Gallinazo Period, the Salinar Period, and the Inca Period, were found by Amat during work in this area (Lumbreras 1970:42, 49; Lumbreras, personal communication, 2001). Part of the large canal underneath the Plaza Mayor was filled with late period burials, which were excavated by the Instituto Nacional de Cultura in 1998, with documentation assistance by members of Rick's Stanford team. Late additions were made to staircases on Building E, but access to the top of the mound was maintained. These features suggest that the monumental center at Chavín apparently retained some of its religious associations post-collapse, and that activities may have been relegated to the area near the Plaza Mayor, away from the settlements in the Circular Plaza Atrium.

Relationships with other sites, chronology, and causes of decline

The conclusion that Chavín reached its final monumental construction stage by around 750 B.C. and had destabilized and declined by around 500 B.C. corresponds with the pattern of decline of many coastal centers by 500 B.C. (Burger 1981, Moseley 1992). This suggests that Chavín coexisted with many other centers of the late Initial Period and the early Early Horizon, and declined around the same time as these sites as well. This conclusion modifies the conclusion reached by Burger (1981), in which he postulated that Chavín's hypothesized apogee and construction of the New Temple between 390-200 B.C. followed and may have been caused by the decline and collapse of coastal sites such as Haldas, Caballo Muerto, and Ancón by the 4th-5th centuries BC. Evidence presented here suggests that Chavín coexisted with the latest phases of these sites during the late Initial Period and early Early Horizon, and that its significant decline by the middle of the first millennium B.C. was roughly contemporaneous with theirs. Rather than being the "Mother Culture" or origin of Andean civilization, as proposed by Tello (1960), or the

terminal synthesis well after the collapse of earlier coastal societies, as postulated by Burger (1981), Chavín appears to be coeval with many coastal monumental centers that developed in the late Initial Period and the early Early Horizon and had collapsed by the middle of the first millennium B.C.

The relationships between Chavín and other highland sites such as Kuntur Wasi (Inokuchi 1998), Huacaloma (Terada and Onuki 1982; Seki 1998), Pacopampa (Rosas y Shady 1974; Morales 1998), La Galgada (Grieder and Bueno Mendoza 1985; Grieder et al. 1988), Huaricoto (Burger and Salazar-Burger 1985) and Kotosh (Izumi and Sono 1963; Izumi 1971; Izumi and Terada 1972) warrant further research due to these conclusions. Investigations will shed light on how the changes at these highland sites relate with those that occurred at Chavín.

Because Chavín's construction appears to have corresponded chronologically with the construction of other monumental centers on the coast and in the highlands, the similarities in architecture and art between Chavín and these other sites likely are based in part on interactions between existing sites, rather than largely drawn from collapsed antecedent societies. Art at Chavín and the incorporation of highland and coastal forms into the architecture at Chavín may have been due to a process of interactions with and influences from coeval sites as well as to the incorporation of antecedent forms.

The earliest phases of Chavín's monumental architecture remain to be dated; absolute dates thus far exist only for Chavín's final monumental construction stage. Burger (1981, 1984) has argued that the Urabarriu-phase ceramics (850-460 B.C.) found in his excavations outside the monumental center were from the earliest settlement at Chavín, due to their stratigraphic location above sterile ground and the lack of earlier ceramics found by prior investigators (Burger 1981:593-595). In contrast, Lumbreras (1993:354) argues that Urabarriu-phase ceramics are not well-known and likely can be subdivided into more phases. He suggests that remains dating to the Initial and Preceramic Periods may exist underneath the modern town and the monumental center,

hypothesizing that construction of the monumental center began earlier than the Urabarriu and Ofrendas ceramic phases (Lumbreras 1993:353-354).

While more work is required to determine the absolute chronology of Chavín's earliest phases, many factors suggest that the chronology of the monumental center at Chavín may extend significantly back into the Initial Period (1800-900 B.C.): the length and complexity of the sequence prior to the construction of the final monumental stage around 750 B.C.; the complexity of the early gallery constructions of the NEA, particularly the Escalinata Staircase, suggesting a prior developed expertise in constructing galleries and internal staircases; the highland antecedents of the early architectural phases, discussed above; and the strong possibility, based on patterns seen in the known phases, that earlier structures may have been covered by the earliest-known buildings including the NEA, the B Platform, Low Building C, Building D, and Early Building E. Additionally, other factors regarding why evidence of earlier occupation has not been found thus far may include: the possibility discussed above that occupation in the area surrounding the monumental center may have been restricted during the Urabarriu phase, which may imply a similar restriction was in place prior to the Urabarriu phase; the very limited extent of excavations into Chavín-period constructions at the monumental center; the limited scope of excavations outside the monumental center; and the large areas of the site that remain to be uncovered, in particular the structures of the West Field. These points suggest not only that the known construction sequence likely extends well back into the Initial Period, but that earlier structures and ceramic phases may remain to be identified.

The causes and nature of the collapse of coastal sites and Chavín warrant future research. Evidence of a large flood in the Moche Valley that may have occurred around 500 B.C. (Nials et al 1979:10), followed by a period of severe landscape degradation (Moseley et al. 1981:249), has led researchers to postulate that the collapse of coastal sites prior to and around this time may have been due in part to destabilization caused by a major El Niño event (Burger 1988:141-142). Evidence of two large El Niño flood events in the Casma Valley date to 1240 +/- 55 B.C. and to

A.D. 16 +/- 163 (Wells 1990:1136-1137). While these dates do not correspond with the estimated 500 B.C. date in the Moche Valley, large flood events do erode much of the lower flood plane along with evidence of smaller events that may have occurred between large events, suggesting that every El Niño event is not recorded stratigraphically (Wells 1990:1135-1136). More work remains to be done in determining the role El Niño events and other environmental factors may have played in the collapse of Initial Period and Early Horizon sites in the north-central Andes.

Implications for interpretation and reevaluation of the Chavín horizon

The Chavín horizon has been defined by Burger as the period of panregional exchange, technological innovations in textiles and metallurgy, and widespread Janabarriu-related ceramics, dating to between 490-200B.C. (Burger 1993:55; 1992; 1988). Burger has postulated that this period corresponds with the peak of a "Chavín cult" and the apogee of construction and functioning of the monumental center at Chavín de Huántar. I argue that Janabarriu ceramics are not associated with the peak in construction and functioning of the monumental center at Chavín de Huántar, but rather appear after the center has physically destabilized, fallen into disuse, and the nature of its function has significantly changed. This suggests that the widespread Janabarriu-related ceramics, panregional exchange, and technological innovations that appeared between 490-200B.C., defined by Burger as the Chavín horizon, are in fact a post-decline phenomenon that does not represent a "Chavín cult" associated with the functioning of the monumental center at Chavín de Huántar.

Significant increases in exchange, task differentiation, and incipient socioeconomic stratification developed during the Janabarriu period at Chavín de Huántar, between 390-200 B.C. (Burger 1981:600, 1984, 1992:170-171; Miller and Burger 1995). Rather than being the result of increasing authority and influence of the monumental center, as postulated by Burger, these social changes could be a result of local competition that developed after the site had declined and its

function had significantly changed. Local groups or families competing for power in the absence of the dominant temple authority may have stimulated wide-ranging exchange and the emerging class structure that appeared during the Janabarriu period at Chavín de Huántar.

CHAPTER 8

CONCLUSIONS

The architecture at Chavín de Huántar is truly monumental. Its elaborate stone buildings, terraces, and sunken plazas combine with its intricate internal gallery system to make the site, and the experience of being there, extraordinary. But while the specific combination and forms of internal and external architecture at Chavín may be unique among monumental centers in the Andes and indeed the world, the complexity of that architecture is not. Complex monumental architecture is a hallmark of prehistoric complex societies that holds great insights into prehistoric construction principles, sequence, chronology, site use, and ideology -- if its complexity can be understood. My research presents a new methodology with which to study monumental architecture in order to gain an understanding of its complexity. New field methods enable precise, three-dimensional documentation of internal and external architecture and the chronological features within it, while new analysis methods enable the systematic study of the spatial relationships within the architecture. These methods provide a way to isolate construction phases, elucidate construction principles, and determine the construction sequence of complex architecture, in order to examine how that architecture changed over time, and to gain insight into how site use and ideology may have changed with it.

Using these new methods, I determined that the construction of the monumental center at Chavín de Huántar was significantly different and more complex than previously postulated. The site was constructed in a complex sequence of at least fifteen rather than three phases. These phases can be grouped into larger stages, beginning with the Separate Mound Stage, the Expansion Stage, the Consolidation Stage, the Black and White Stage, and the Support Construction Stage. Within these stages, large, high-volume constructions containing elaborate

galleries and gallery patios were built early in the sequence. In the Black and White Stage, the final monumental construction stage, construction shifted to lower volume, high-area, highly decorated surficial constructions containing simpler, standardized galleries. The richness of the architectural sequence makes it clear that a simple Old Temple-New Temple distinction neither sufficiently nor accurately represents the complexity of Chavín's architectural sequence.

In the final monumental stage, standardized galleries were constructed along with all of the site's known sunken plazas, which contain fine stonework sometimes carved with reliefs. Gallery patios built in earlier stages were filled and covered with galleries in this stage, which were no longer as elaborate and uniquely formed as those in earlier stages. This suggests a major shift in emphasis in site use in this final monumental stage, towards activities that require large, visually decorated outside spaces, rather than elaborate internal spaces associated with small external patios. The galleries continued to function during this stage, however, as integral elements of the site. For example, in the final monumental stage, early forms of the Lanzón Gallery and the Laberintos Gallery were expanded and connected to become one dual-level complex, integrated with the construction of the Circular Plaza Staircase, the Circular Plaza, and its surrounding standardized galleries. These constructions in the area surrounding the Lanzón monolith suggest that the Lanzón monolith itself maintained and perhaps increased in ideological importance over time, rather than declining after the beginning of the sequence as has been previously postulated.

From the earliest stages and throughout the sequence, internal and external architecture were planned and constructed as part of a single design. Architectural principles such as symmetrical staircases were evident in the earliest stages at Chavín, and were modified throughout the sequence as necessary to adapt older phases to new constructions. This process frequently involved partial deconstruction and modification of earlier phases in attempts to unify the combined whole. Hanging staircases appear to have played an important role, perhaps as transition spaces between symbolically distinct upper and lower levels of the temple.

The earliest stages contain local highland architectural forms of separate mounds with stone facades, internal gallery structures, ventilation shafts, and freestanding rectangular structures. These highland forms continue through the sequence, while coastal architectural forms are incorporated over time, including large stepped platforms and possibly a U-shaped form during the Expansion Stage, and a formal U-shaped form and a sunken circular plaza in the Black and White Stage. Architectural aspects unique to Chavín are present in the beginning of the sequence, including galleries that are structurally elaborate and integral to the site.

Whereas contiguous phases can be sequenced in large part by analyzing external and internal seam abutments, the standardization of gallery forms and features over time provides the primary chronological link between late non-contiguous phases within the site. The resulting construction sequence presented here demonstrates that key areas of the site that were thought to be early were in fact built in the final monumental construction stage. In particular, the sequence indicates that the Circular Plaza and the Ofrendas Gallery, which were previously postulated to be part of Chavín's first phase or Old Temple, were built in the site's final monumental stage. Radiocarbon dates associated with these key areas therefore correspond with the final monumental stage of construction rather than the first.

Radiocarbon dates directly associated with the architecture of the monumental center date the Black and White Stage, the final monumental construction stage, to approximately 750 B.C. Evidence of major efforts to structurally support the architecture exists by 500 B.C., followed by evidence of disuse and physical collapse above the Circular Plaza Atrium by approximately 430 B.C. These dates chronologically anchor the architectural sequence and demonstrate that the final monumental construction stage at the monumental center at Chavín de Huántar was completed or nearing completion by approximately 750 B.C. They suggest that the site had undergone physical destabilization and decline by around 500 B.C., and had entered a period of disuse by approximately 430 B.C., with a distinct change in function. It likely had ceased to function as a monumental center as it had during its stages of monumental construction.

The Ofrendas ceramics are directly associated with the completion of the final monumental construction stage at Chavín and the corresponding dates of around 750 B.C. This suggests that the Urabarru and Ofrendas ceramic phases correspond with the construction of the monumental center at Chavín, while the Chakinani and Janabarru ceramic phases correspond with the post-construction period at Chavín. Radiocarbon dates associated with Chakinani ceramic phase (460-390 B.C.) and the Janabarru ceramic phase (390-200 B.C.) (Burger 1984:229-245; 1995:165) correspond with this pattern, as does the presence of Janabarru ceramics in the stratigraphic layer containing evidence of physical collapse found directly above the floor of the Circular Plaza and associated with a radiocarbon date of 430 B.C.

The two anchor points of the Chavín art sequence postulated by Rowe (1962, 1967), based on his analysis of the architectural sequence, are consistent with the architectural sequence presented here. The Lanzón monolith, Phase AB, is in place by the Expansion Stage, while the Black and White Portal Sculptures, Phase D, were constructed in or just before the Black and White Stage. The construction of the Circular Plaza in the Black and White Stage warrants reevaluating hypotheses that the sculptures of the Circular Plaza are Phase B, and postulating that they are in fact Phase D or possibly Phase E.

The results of this study let us conclude that Chavín was coeval with other Andean sites that were constructed in the late Initial Period through the early Early Horizon and that had collapsed by 500 B.C. Rather than being the “Mother Culture” or the origins of Andean civilization, as proposed by Tello (1960), and rather than being a site that reached its apogee after the decline of the regional centers on the coast after 500 B.C., as proposed by Burger (1981), the monumental center at Chavín likely grew and declined with them.

This conclusion warrants a reexamination of the nature and meaning of the “Chavín horizon”. The Chavín horizon originally was postulated as a period in which art and architectural styles originating at Chavín spread across the north-central Andes (Tello 1960). Evidence subsequently emerged demonstrating that a long sequence of sites with similar art and

architecture preceded Chavín before it appeared relatively late in this sequence (summarized by Moseley 1985). Chavín was then postulated not only to have appeared late in the sequence, but to have reached its peak in influence only after other sites bearing similar art and architectural styles had collapsed by the middle of the first millennium B.C. (Burger 1981). The Chavín horizon was viewed largely as a regional exchange system, founded in the power of the Chavín cult, that corresponded with widespread shared ceramic attributes and technological innovations in metallurgy and textiles, dated to 390-200 B.C (Burger 1981). This Chavín horizon was postulated to have occurred with the apogee of construction of the monumental center, and therefore to represent the peak of a religious cult based at Chavín.

The Chavín architectural sequence presented here demonstrates that construction at Chavín was completed by around 750 B.C. and that the site itself had declined by approximately 500 B.C., followed by disuse, physical collapse, and likely a significant change in function by approximately 430 B.C. This suggests that the widespread exchange network that developed between 390-200 B.C. was not based on the religious power of the Chavín temple at its apogee, but rather developed after the decline of regional centers, including Chavín, on the coast and in the highlands around the middle of the first millennium B.C. This exchange network likely was established among these centers before their decline, but its existence through the end of the Early Horizon likely was not associated with the construction or functioning of the monumental center at Chavín de Huántar. The exchange network likely was free from the influence of a central dominant ideology, stimulated instead perhaps by competition between local groups.

Much research remains to be done to clarify the site of Chavín, the nature of its decline and physical collapse, and its relationships with other sites. At Chavín, future work is needed to uncover buildings and areas that remain largely or partly buried in order to clarify their construction history. Such areas include Building B, Building C, Building D, Building E, and the East Area. Excavation of the foundations of Buildings B and C will help resolve remaining questions about their construction history by perhaps revealing more exterior seams. Further

investigations of the buildings included in the East Area Pre-Black and White Phase will help determine their chronological depth and may help provide greater resolution regarding their construction order within this phase. Areas outside the immediate monumental center warrant investigation as well. The platforms and filled galleries of the West Field suggest a significant portion of the site has yet to be revealed. Remains of galleries in the South Field and in areas north of the site, including underneath the town and up to the north wall, suggest that further work in these areas would be fruitful, illuminating more information regarding the extent and nature of the larger monumental precinct. Additionally, more insight into how the changes manifested in Chavín architecture related to broader cultural changes and social phenomena at Chavín awaits further analysis.

Neither a precursor to the monumental centers of the late Initial Period and the early Early Horizon, nor the late consequence of their collapse, the monumental center at Chavín de Huántar appears to have been coeval with these centers, and part of a network of centers that declined by the middle of the first millennium B.C. This conclusion warrants a reexamination of the nature of the relationships between Chavín and these centers, the widespread decline of these sites, the regional exchange network that developed after their decline, and changes in social organization and population distribution that may have accompanied these significant changes.

APPENDIX A. ILLUSTRATIONS

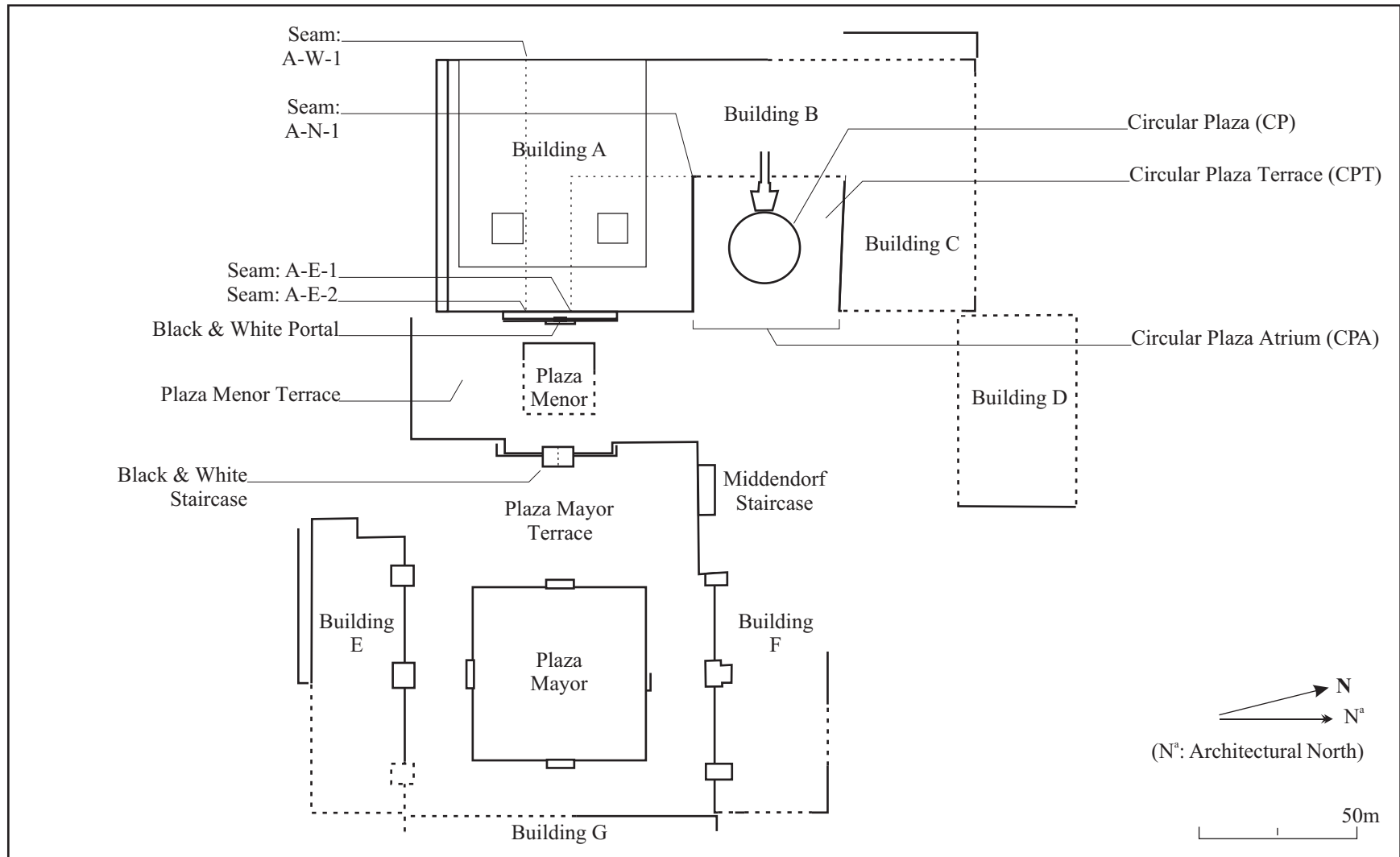

Figure 1.3. Map of external architecture at the monumental center of Chavín de Huántar. Redrawn from Rick et al. 1998:Figure 5.

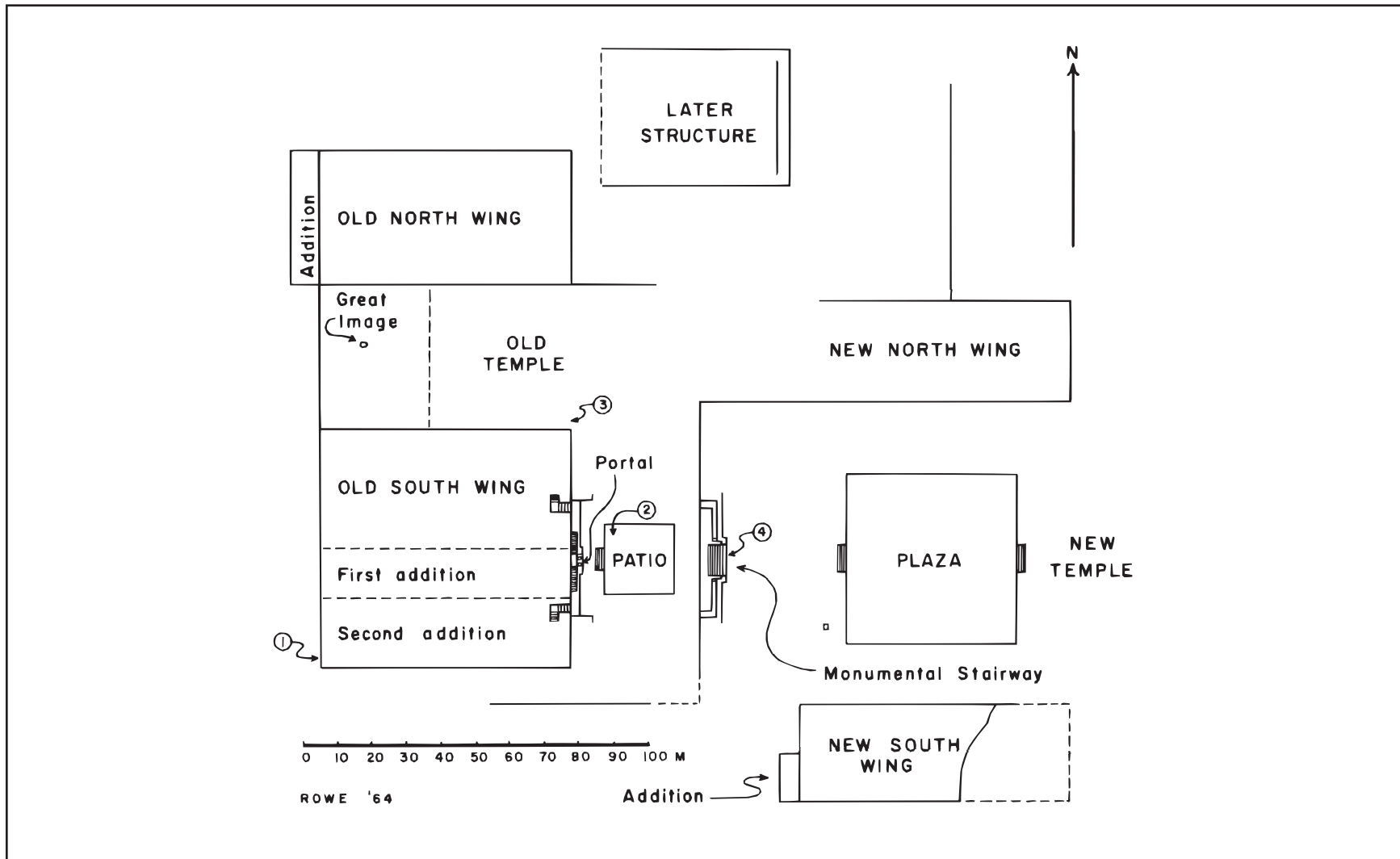

Figure 1.4. Plan of the ruins of the temple of Chavín (Rowe 1967:Figure 2). Depicts a three-phase construction sequence for Chavín, with Old Temple and New Temple designations.

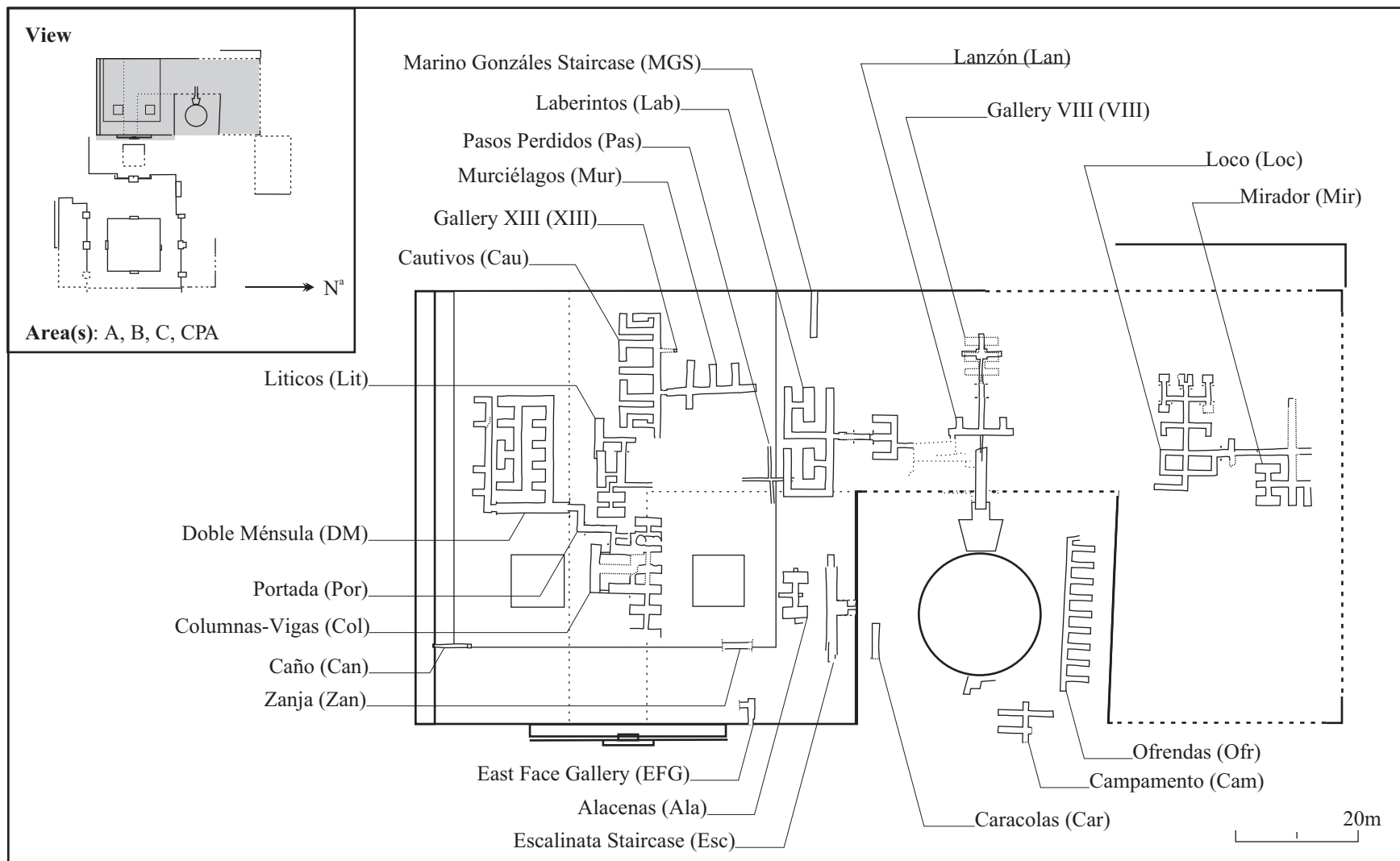

Figure 2.11. Map of gallery locations in Buildings A, B, C, and the Circular Plaza Atrium. Galleries drawn from three-dimensional data. Gallery VIII redrawn from Tello (1960). External architecture based on three-dimensional data collected by John Rick.

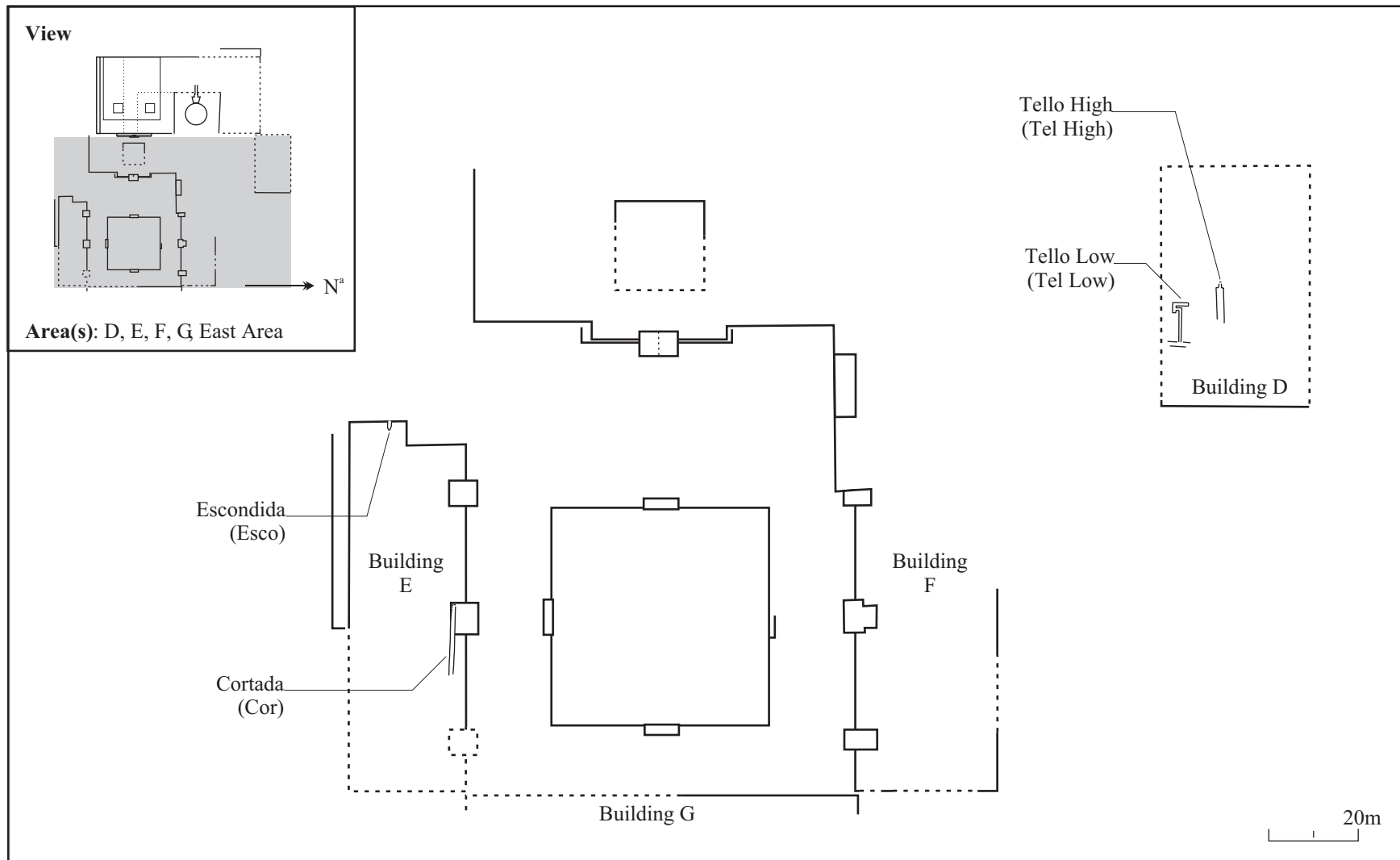

Figure 2.12. Mapped galleries in Buildings D and E, drawn from three-dimensional and measurement data. External architecture redrawn from Rick et al. 1998:Figure 5.

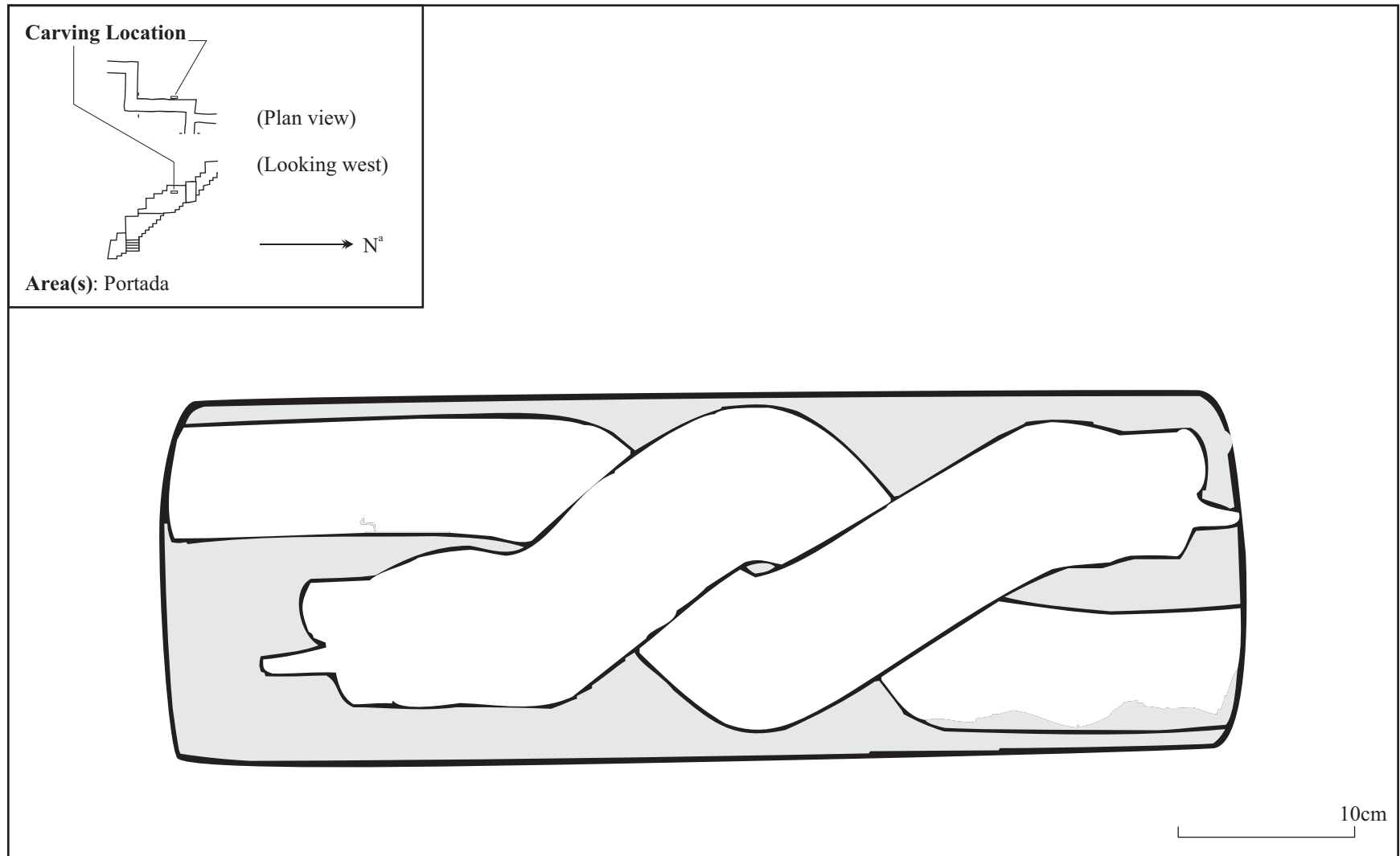

Figure 3.418. Carving of intertwined snakes located in the west wall of the Upper Portada staircase. Block is 60cm x 21cm.

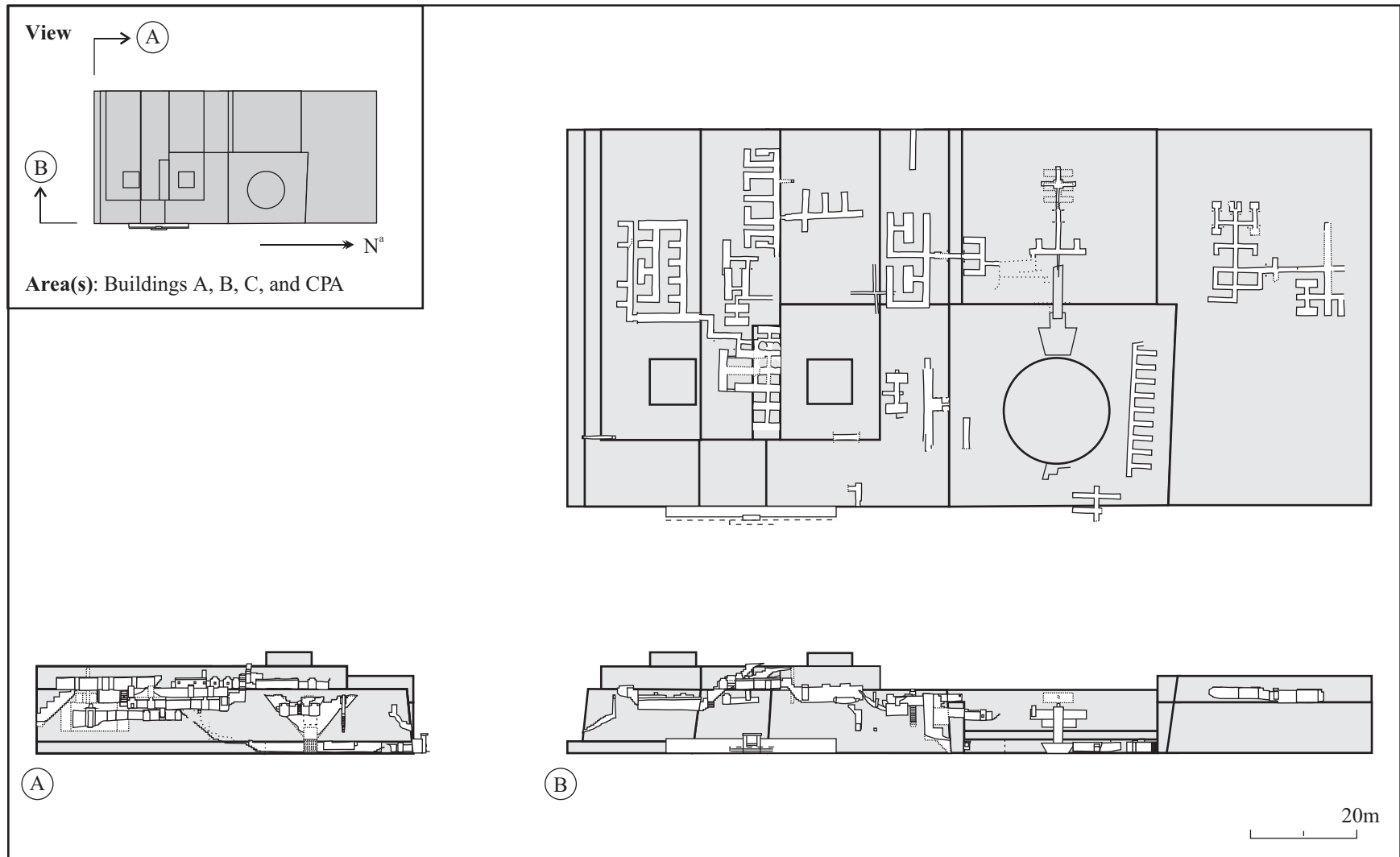

Figure 4.2. Plan and Architectural North (A) and West (B) views of Buildings A, B, C, and the Circular Plaza Atrium. All documented galleries visible. Galleries drawn from three-dimensional data. External architecture based on three-dimensional data collected by John Rick.

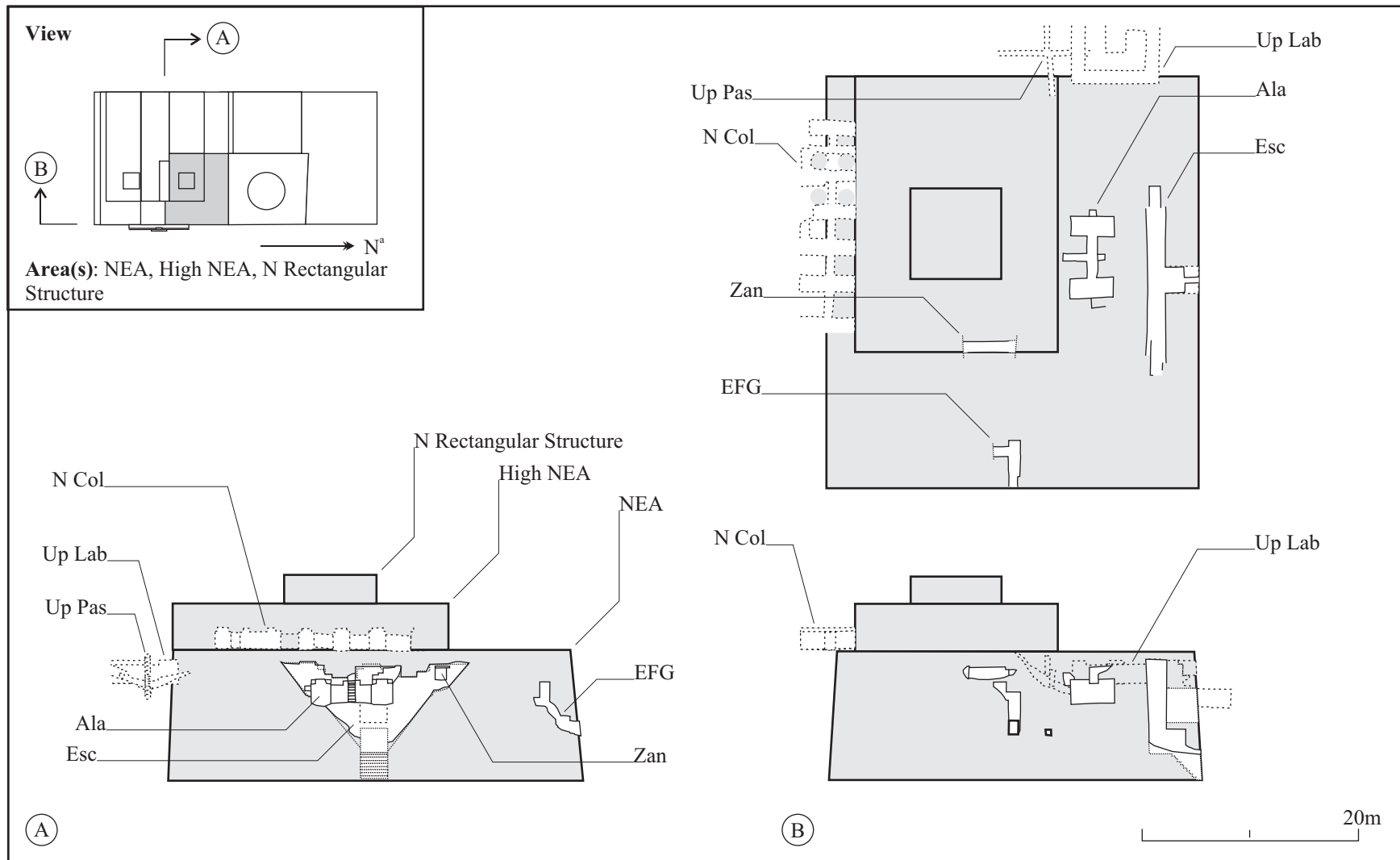

Figure 4.5. NEA (Northeast corner of Building A) area and galleries.

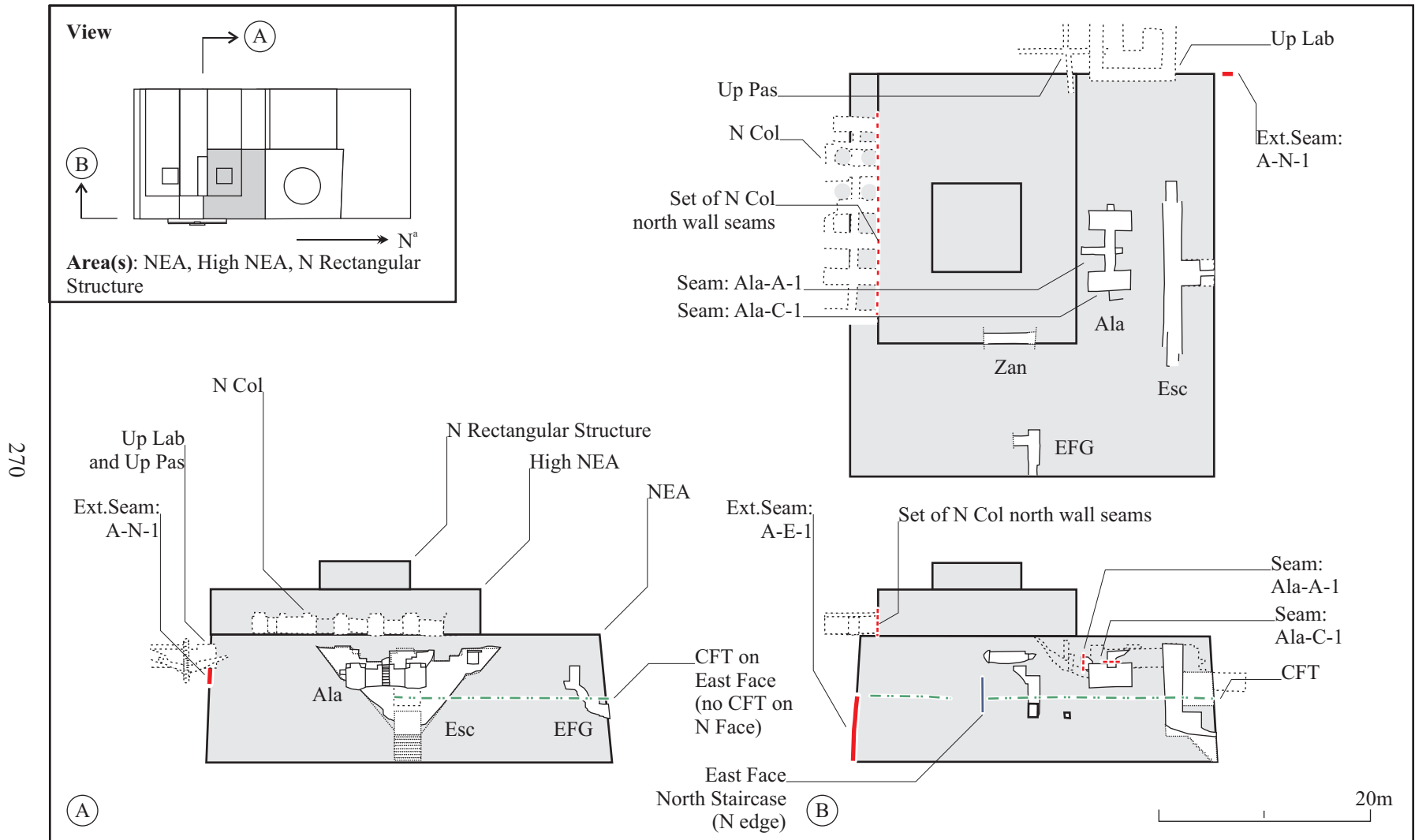

Figure 4.6. NEA area -- Spatial relationships of internal and external architecture.

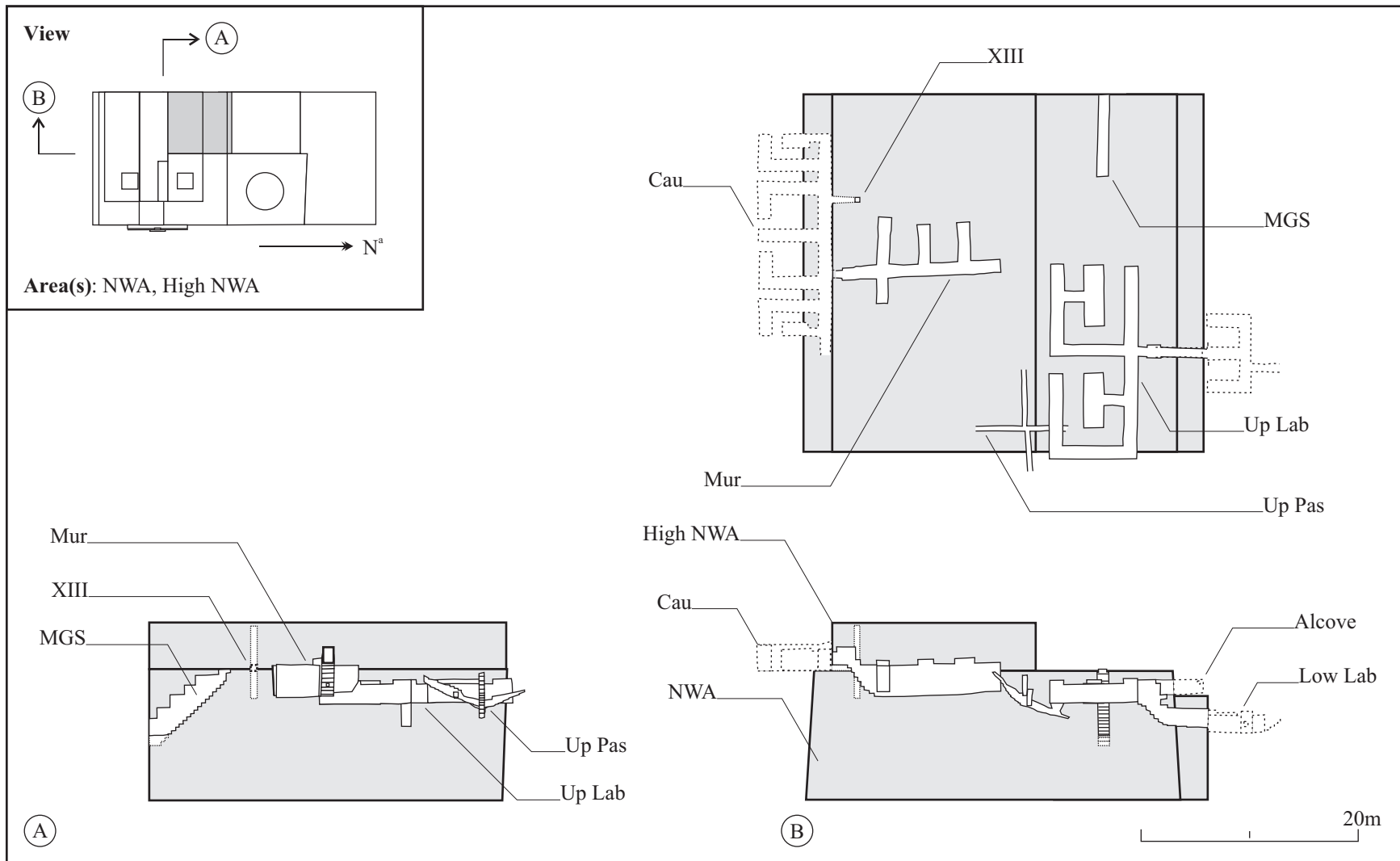

Figure 4.28. NWA (Northwest corner of Building A) area and galleries. Cau and Low Lab not shown in view (A).

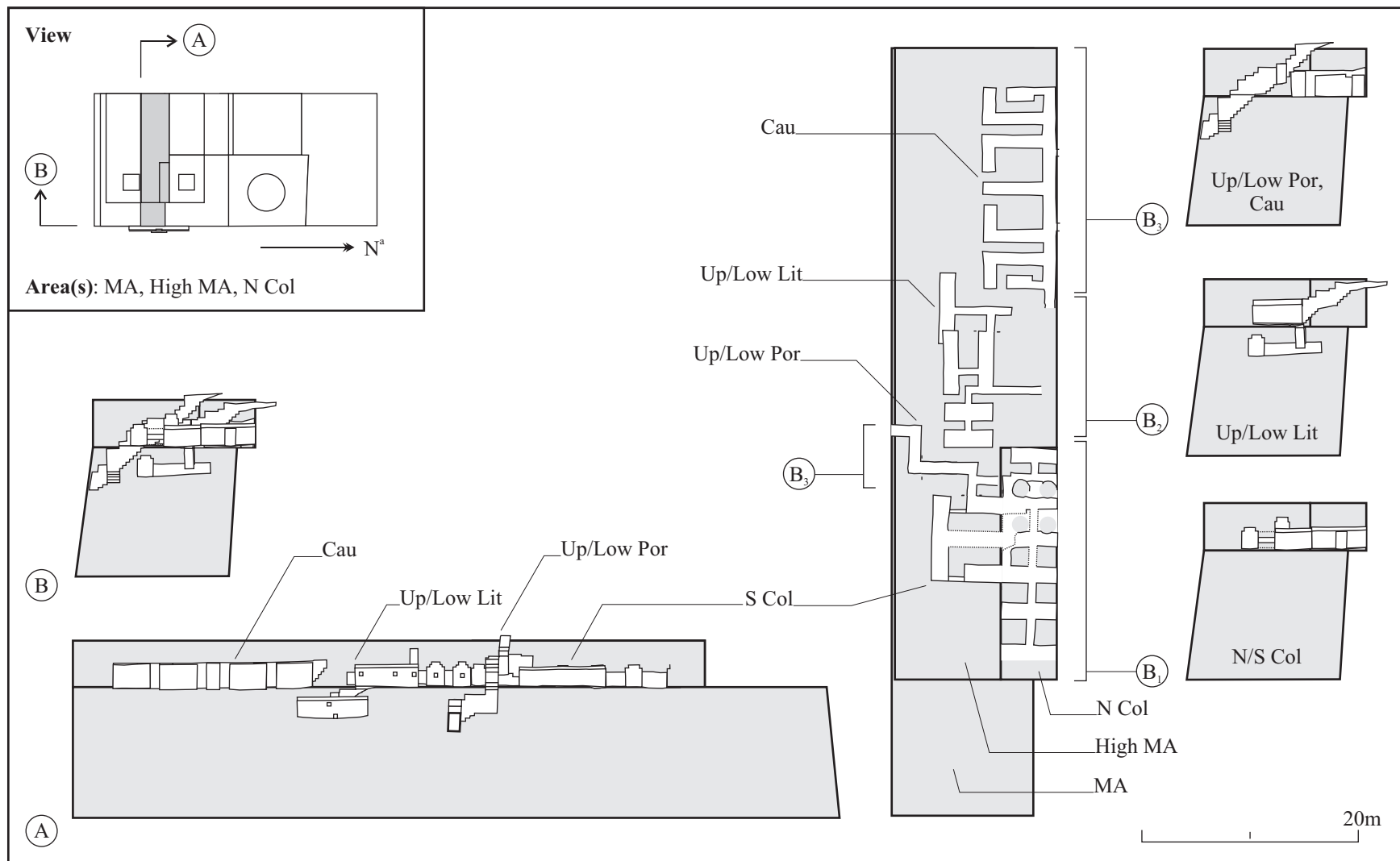

Figure 4.29. MA (middle area of Building A) area and galleries. Liticos vents shown in view (A); Full depth of MA shown in view (B), individual galleries shown in views (B₁-B₃); (B₃) shows Cautivos and Up/Low Portada.

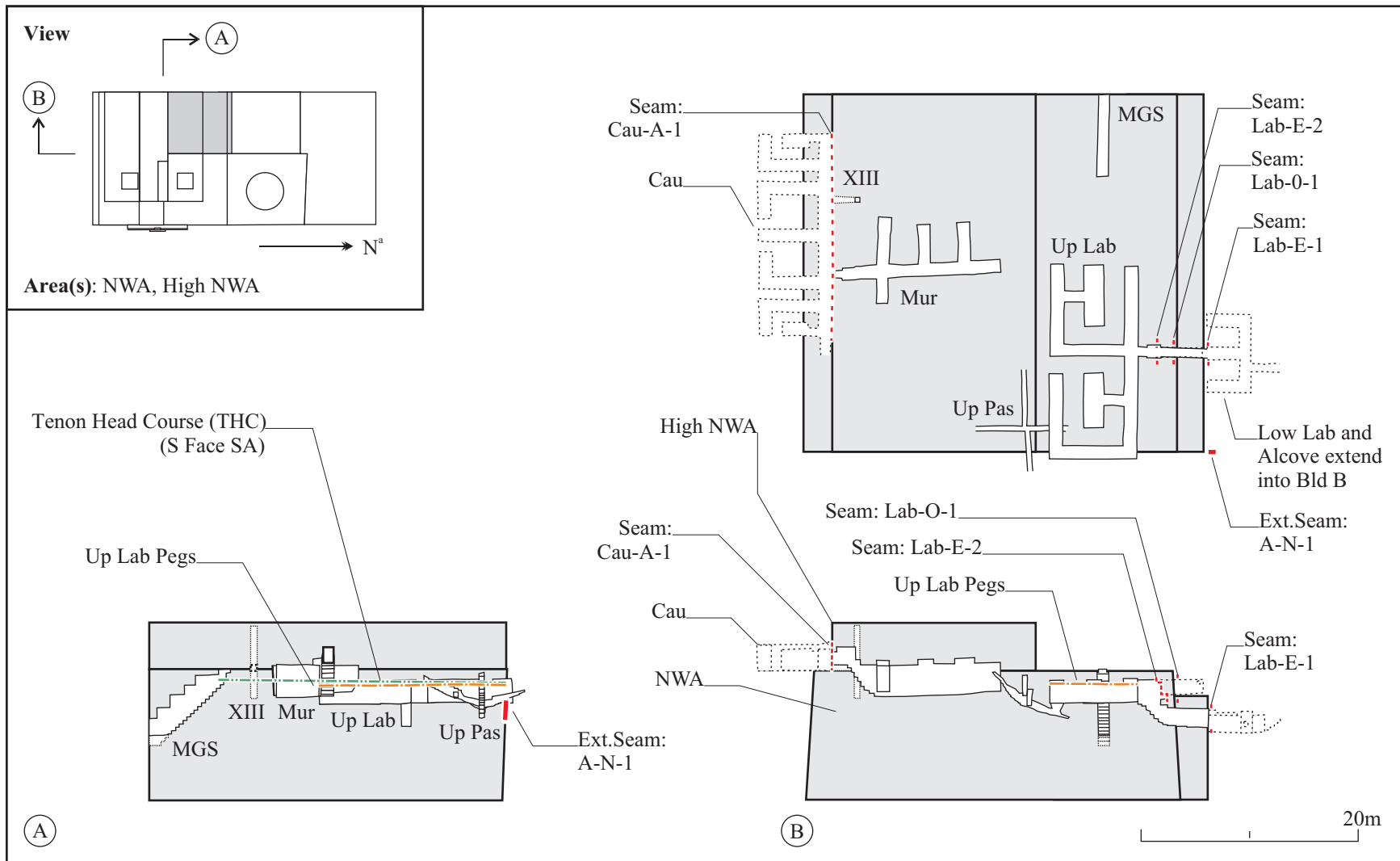

Figure 4.30. NWA area -- Spatial relationships of internal and external architecture. Cau and Low Lab not shown in view (A).

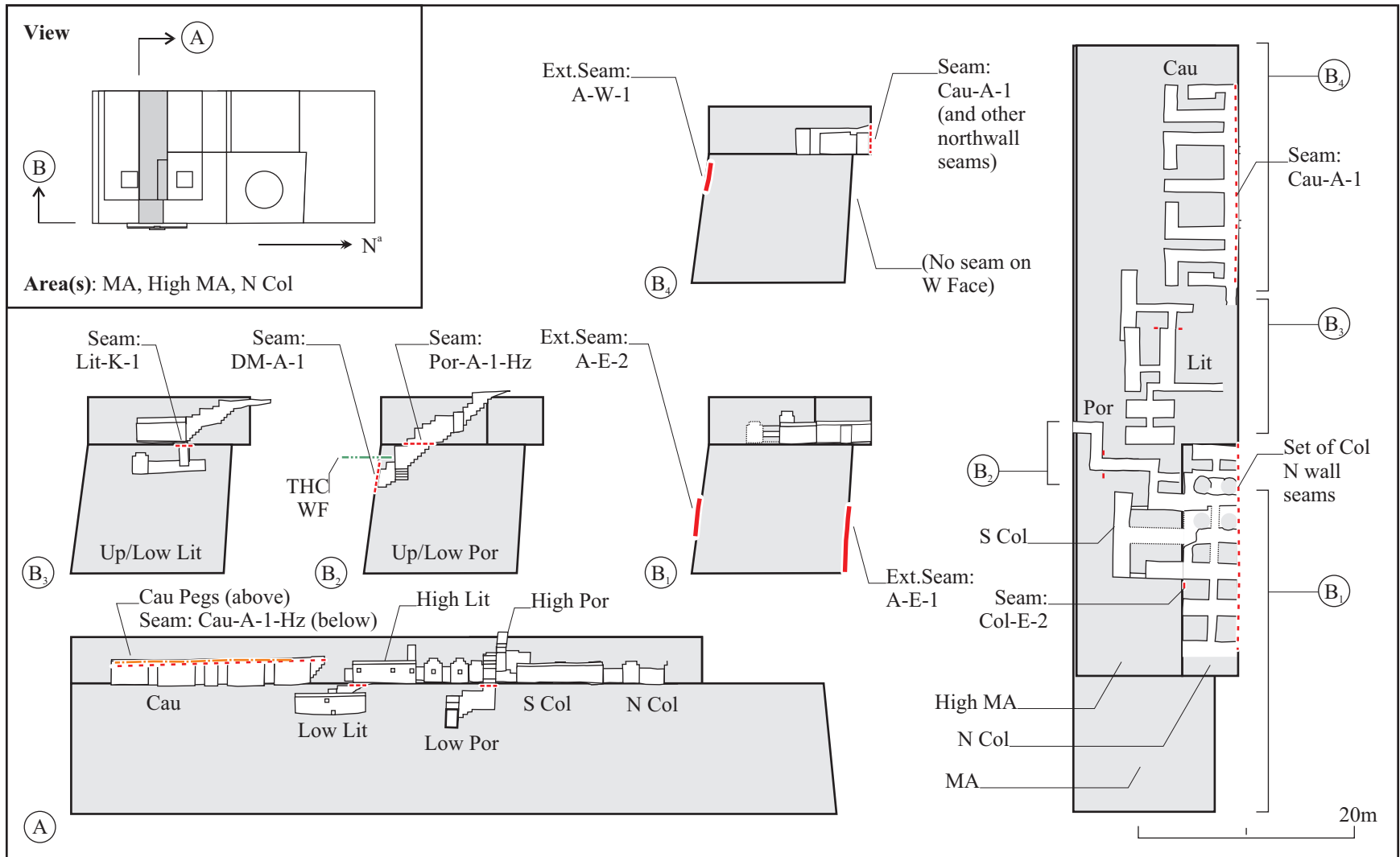

Figure 4.31. MA area -- Spatial relationships of internal and external architecture.

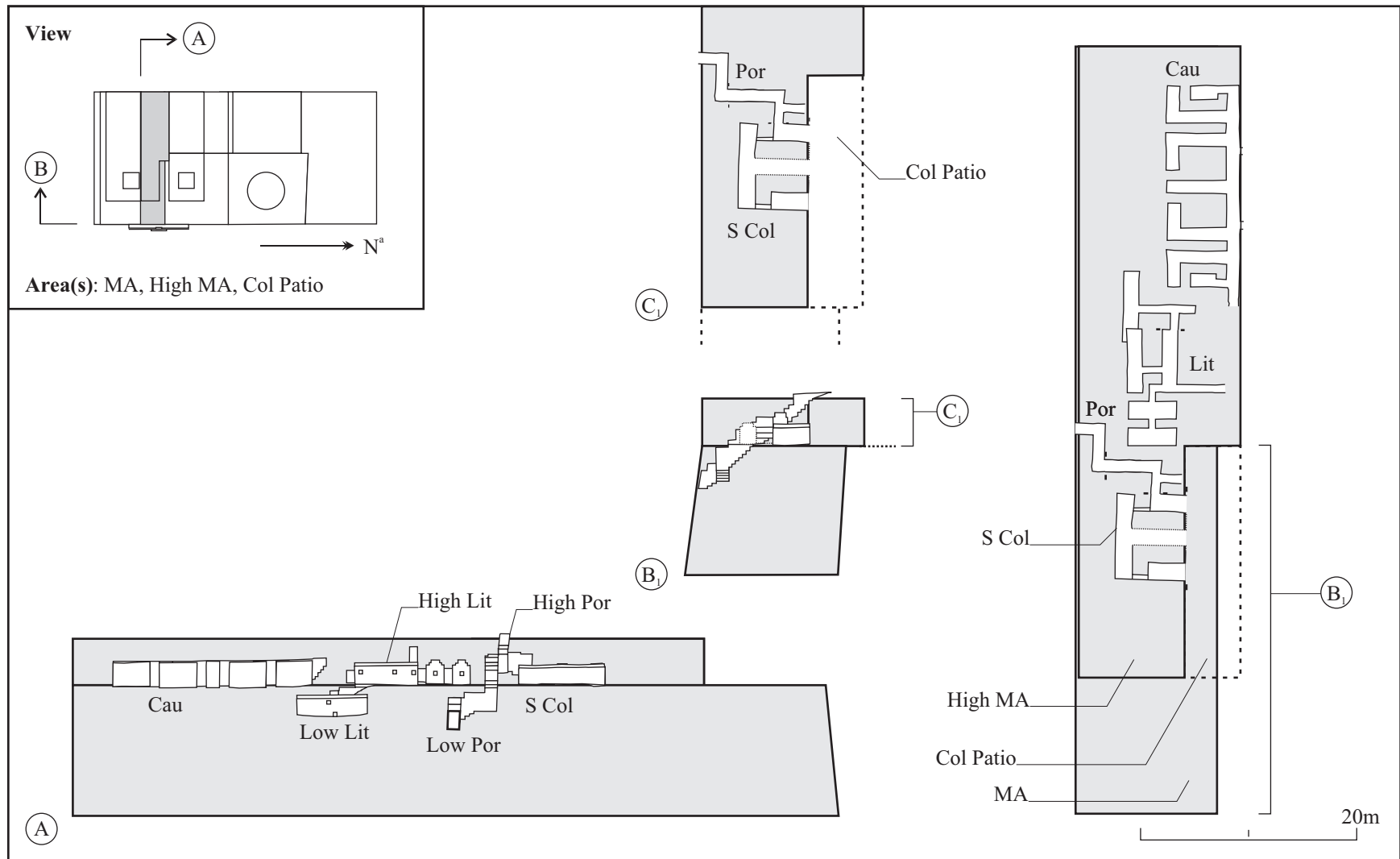

Figure 4.32. MA area with Columnas Patio -- Spatial relationships of internal and external architecture. The High MA forms an open patio (Col Patio) before the construction of N Col.

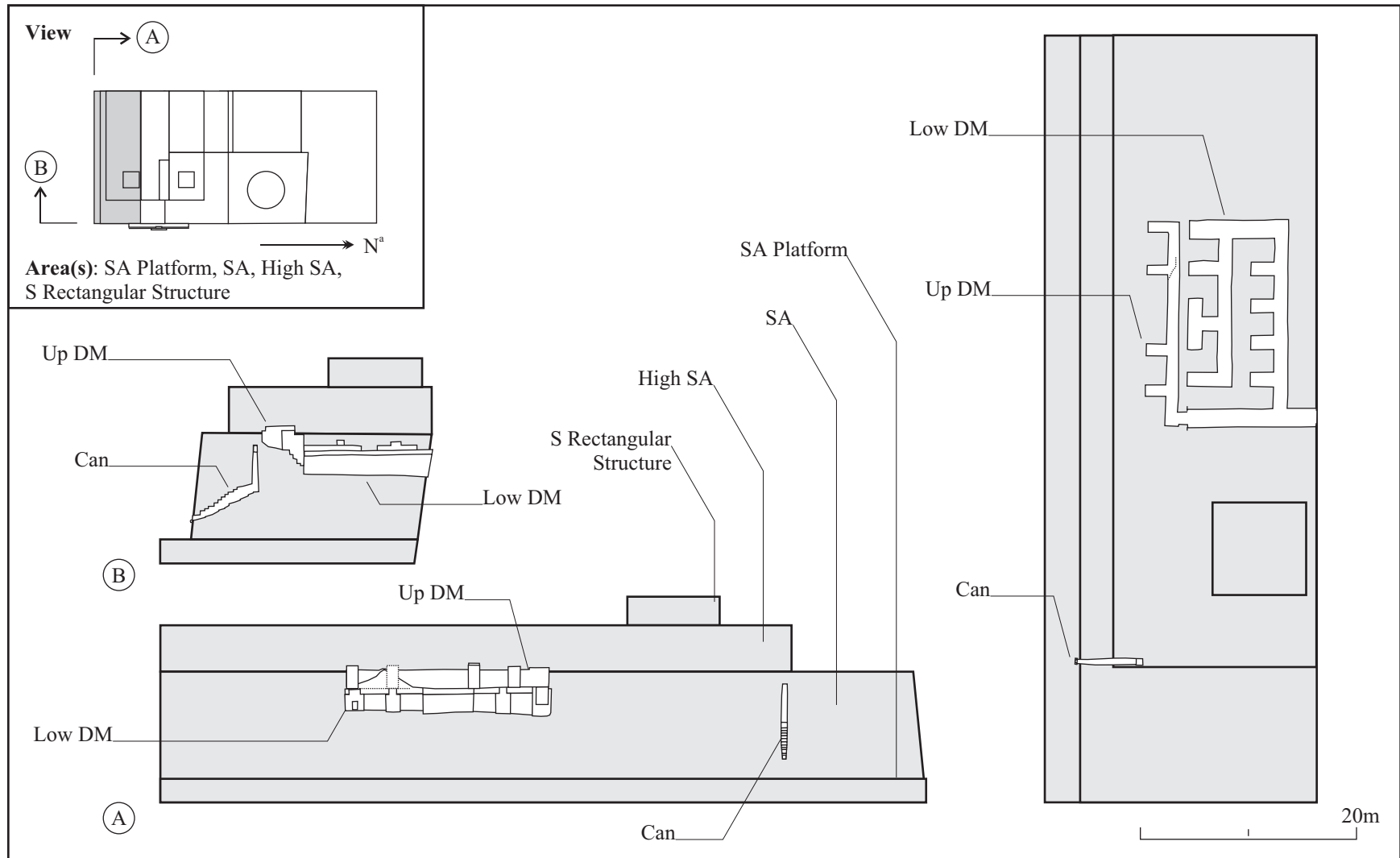

Figure 4.48. SA (South area of Building A) area and galleries.

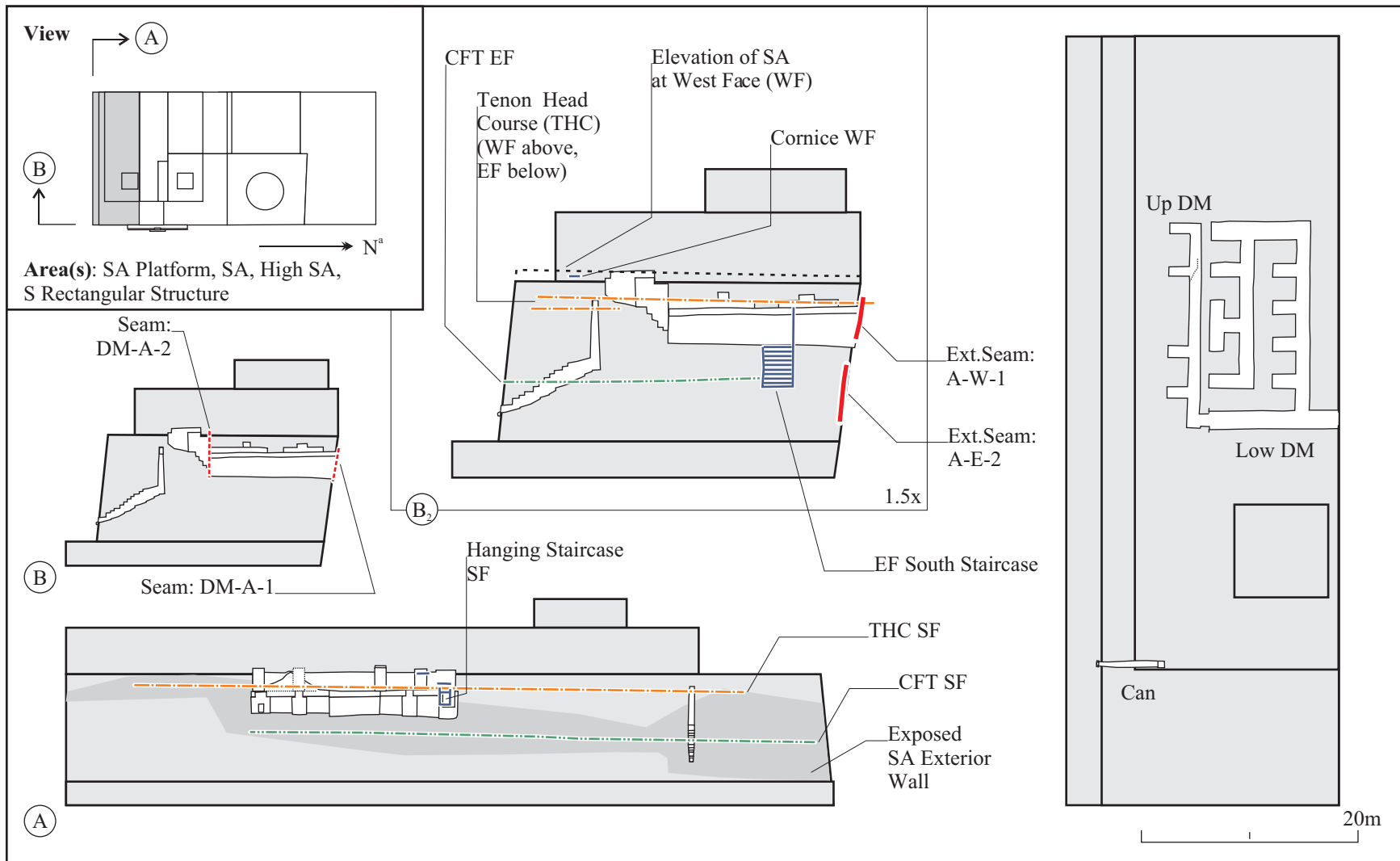

Figure 4.50. SA area -- Spatial relationships of internal and external architecture.

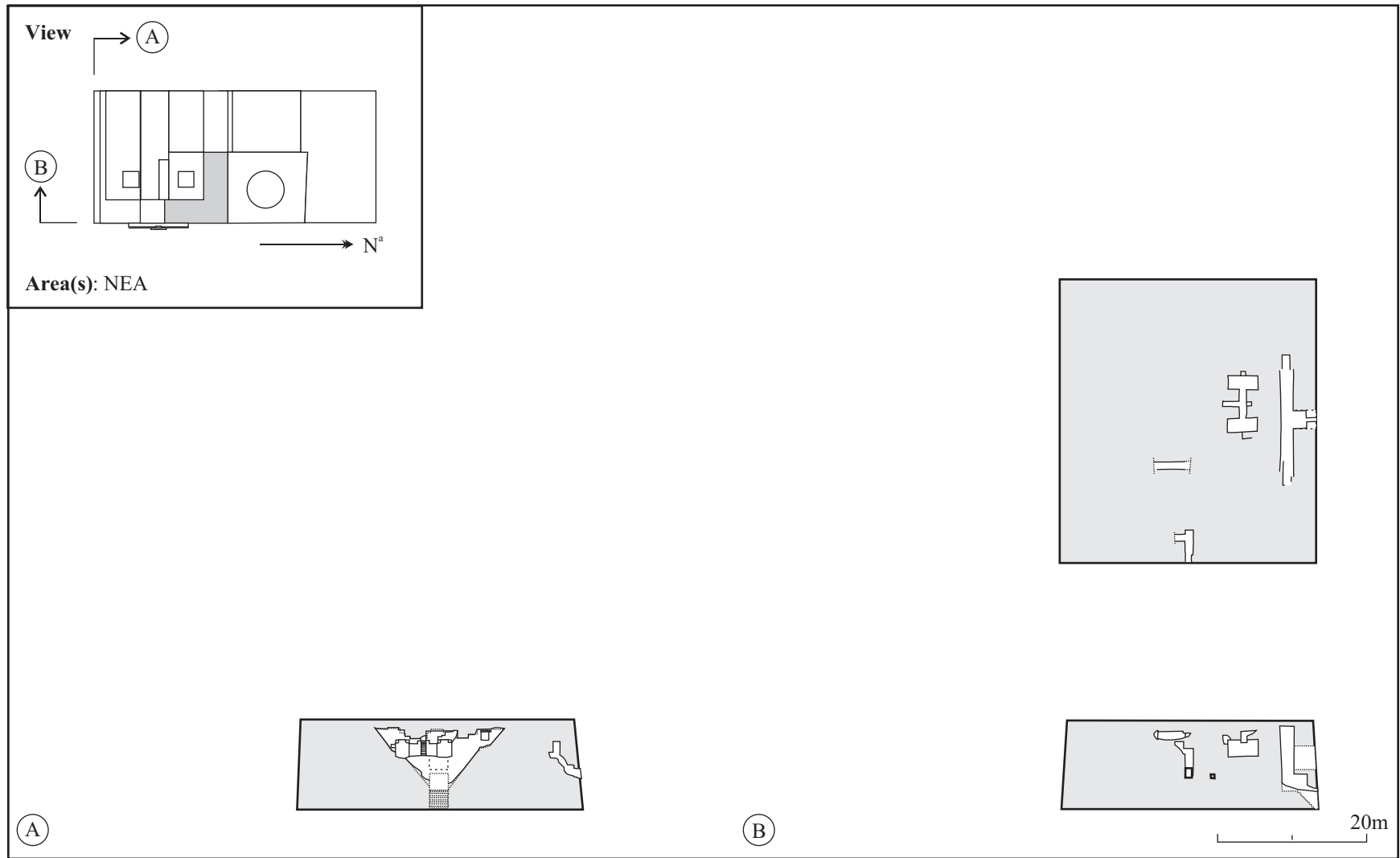

Figure 4.75. Building A Construction Phase 1: NEA Phase.

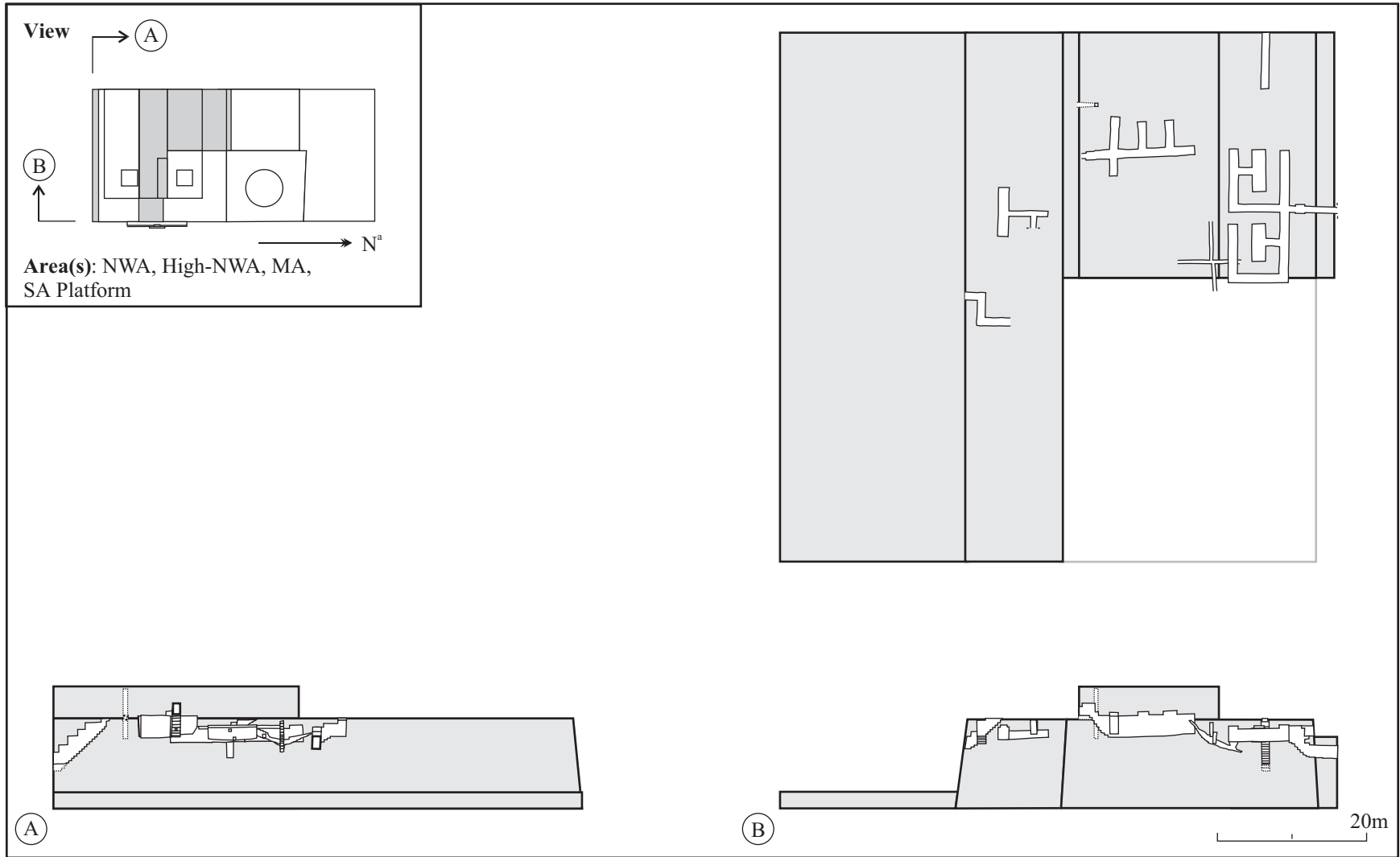

Figure 4.76. Building A Construction Phase 2: NWA-High NWA-MA-SA Platform Phase.

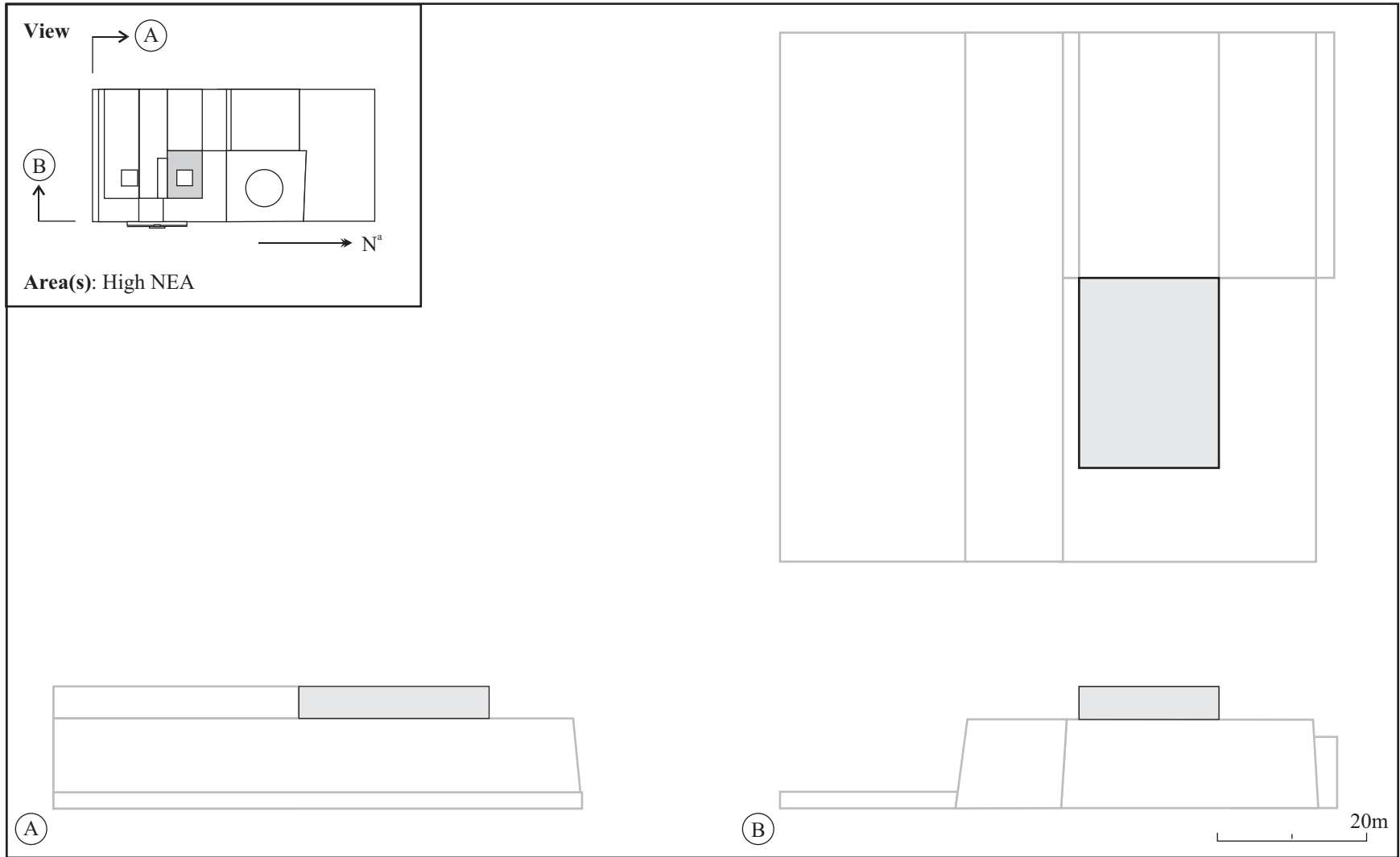

Figure 4.77. Building A Construction Phase 3: High NEA Phase.

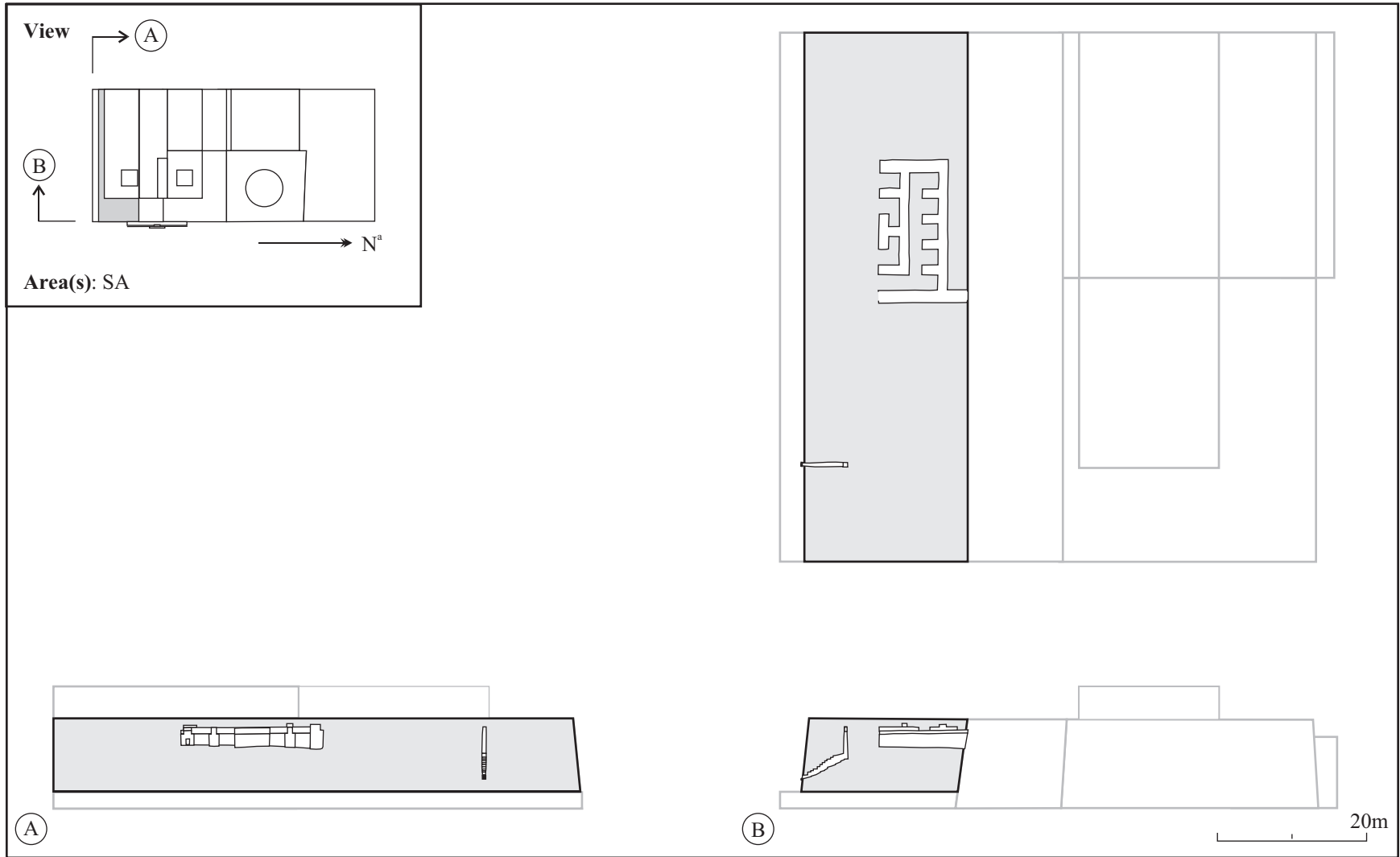

Figure 4.78. Building A Construction Phase 4: SA Phase.

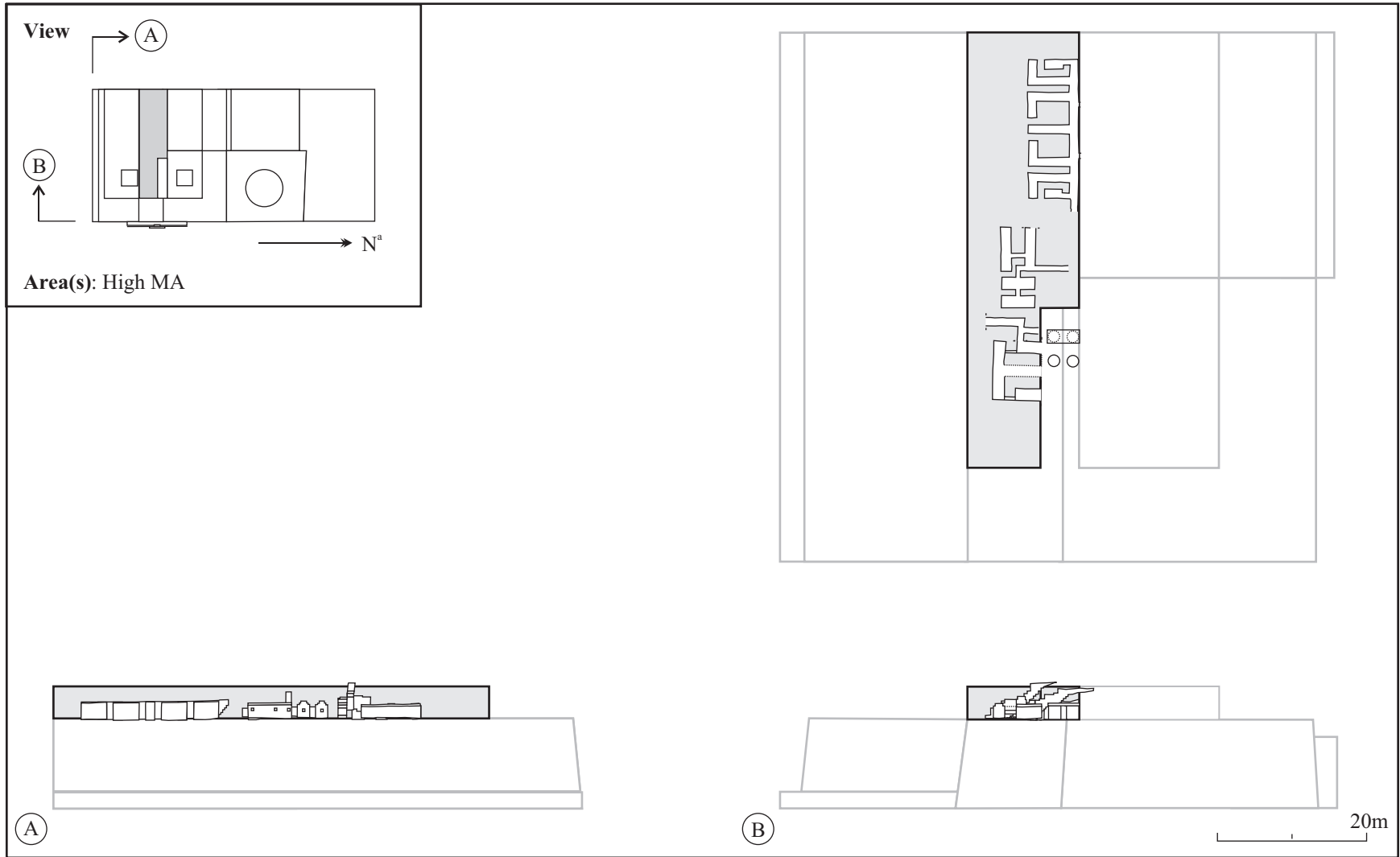

Figure 4.79. Building A Construction Phase 5: High MA Phase.

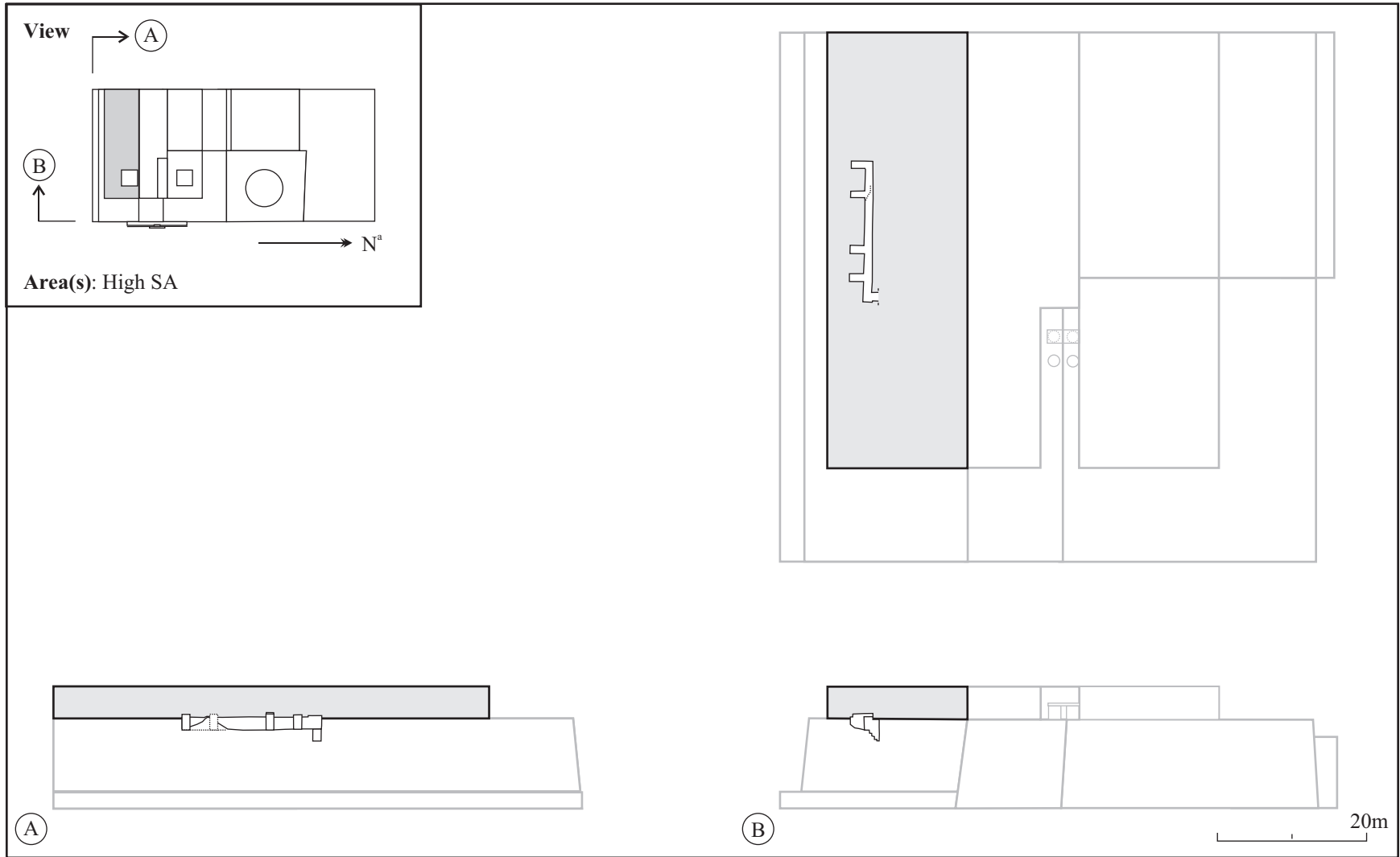

Figure 4.80. Building A Construction Phase 6: High SA Phase.

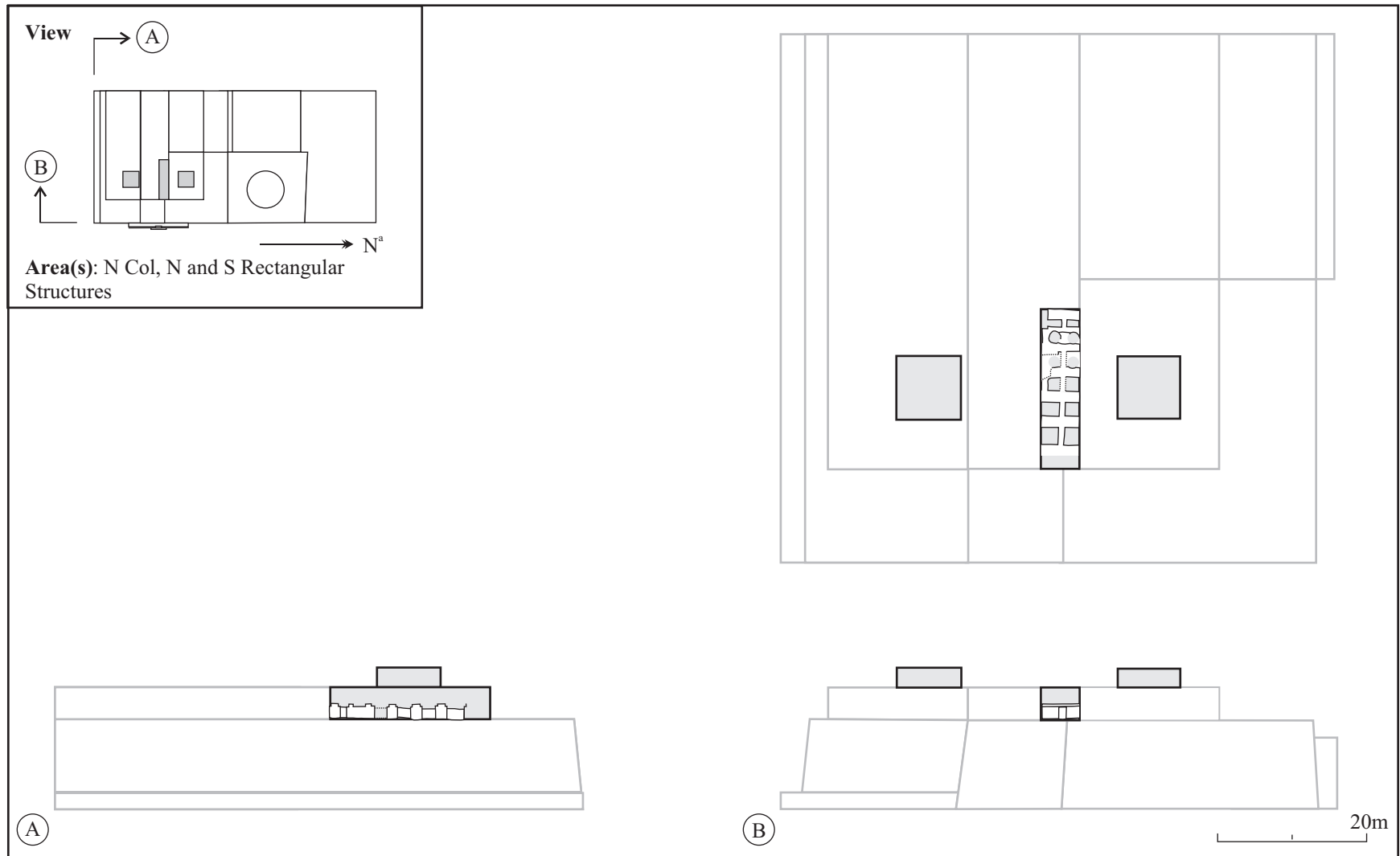

Figure 4.81. Building A Construction Phase 7: Late Building A Phase (Building A Black and White Axis Phase).

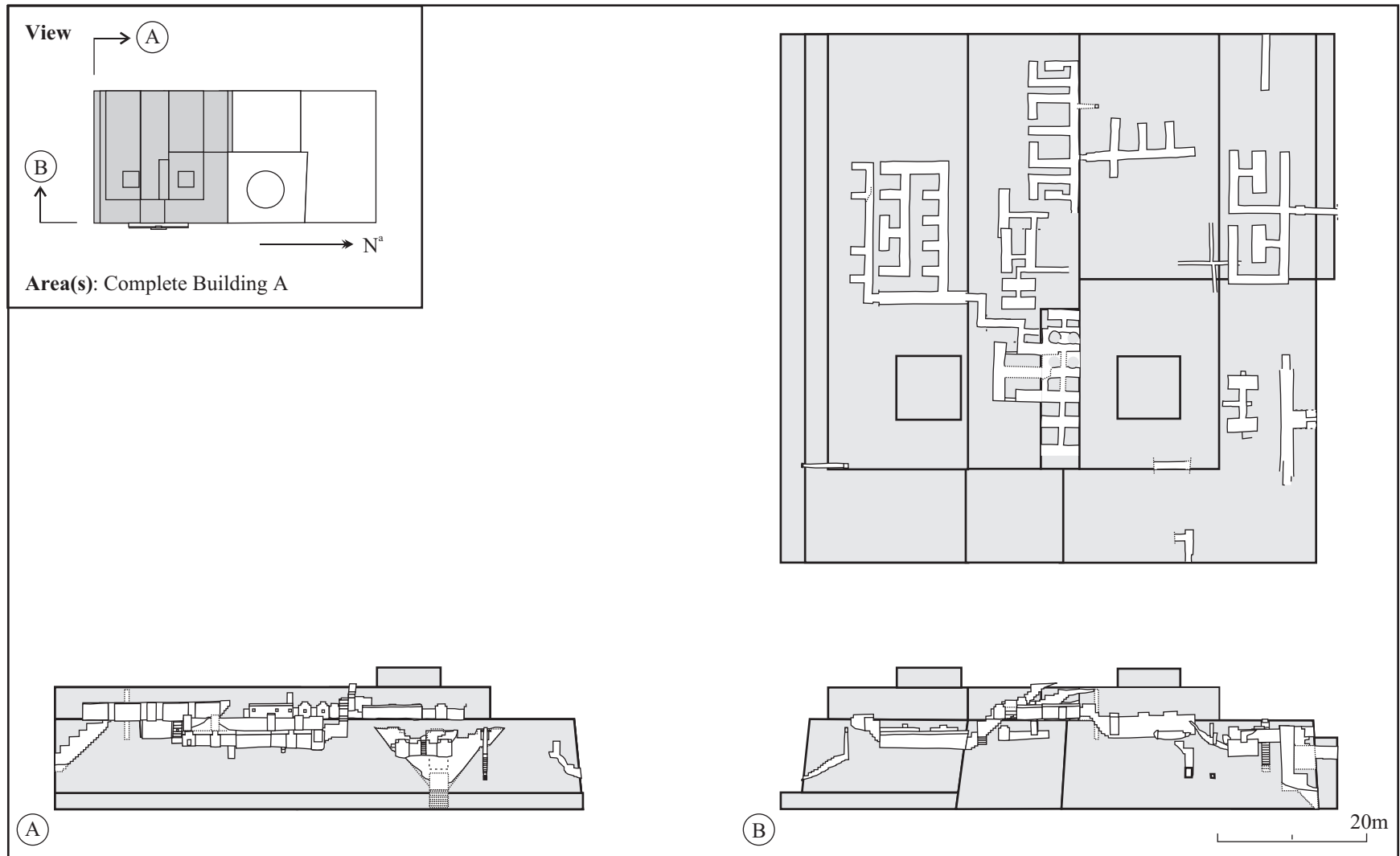

Figure 4.82. Building A Construction Phases: Full Sequence.

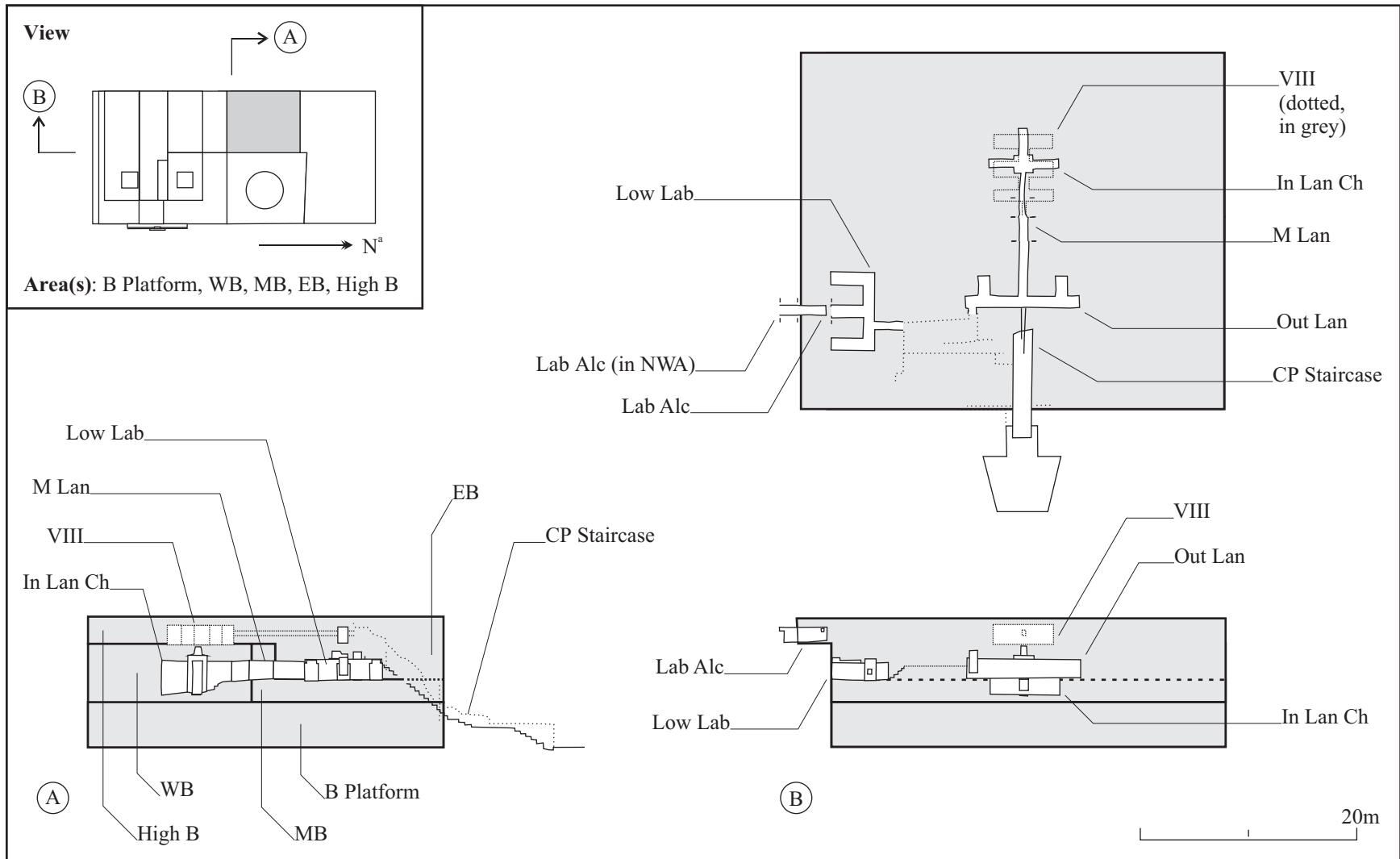

Figure 4.85. Building B area and galleries. Circular Plaza Staircase (CP Staircase) not shown in view (B).

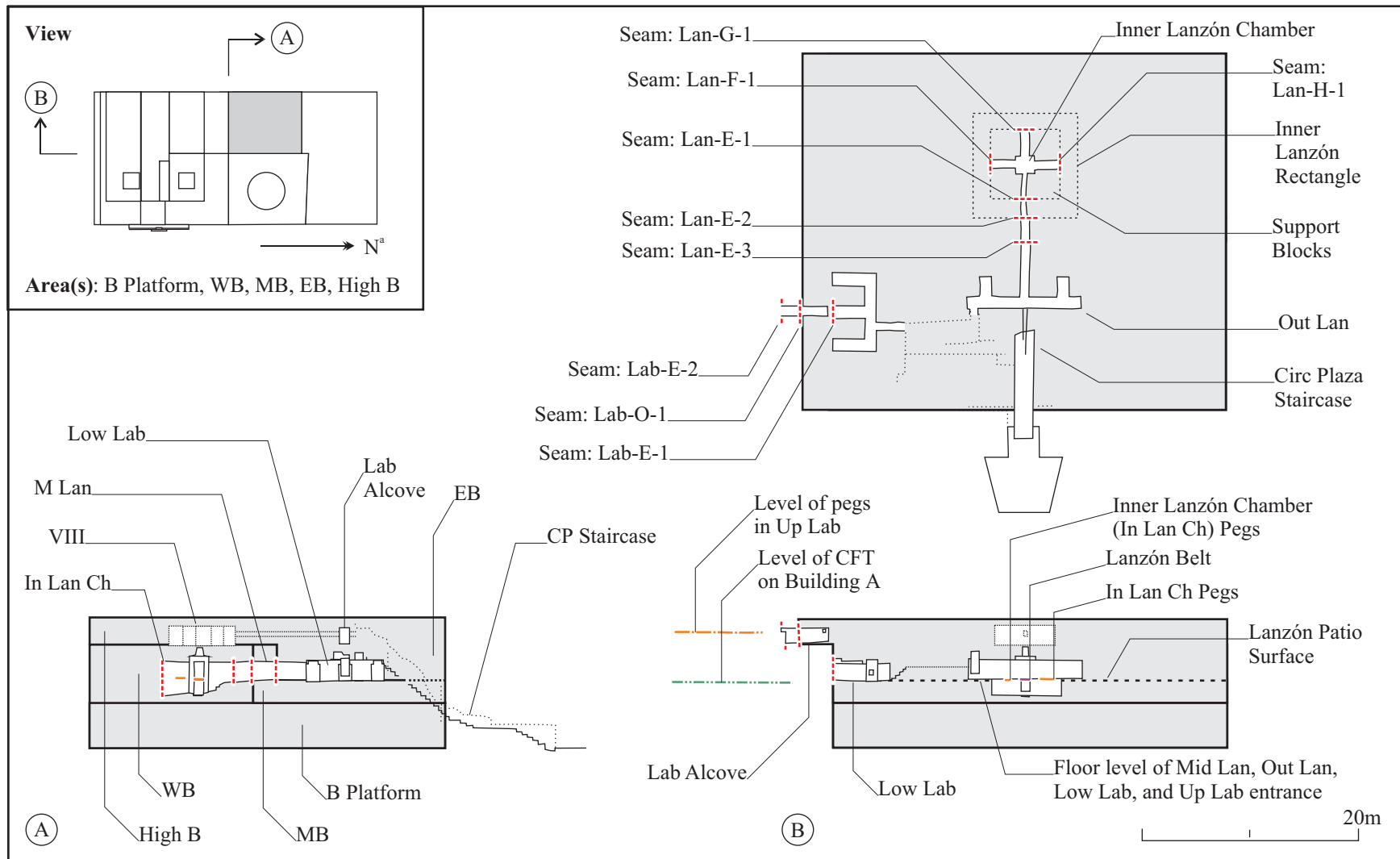

Figure 4.86. B area -- Spatial relationships of internal and external architecture. Circular Plaza Staircase (CP Staircase) not shown in view (B). Gallery VIII not shown in plan view.

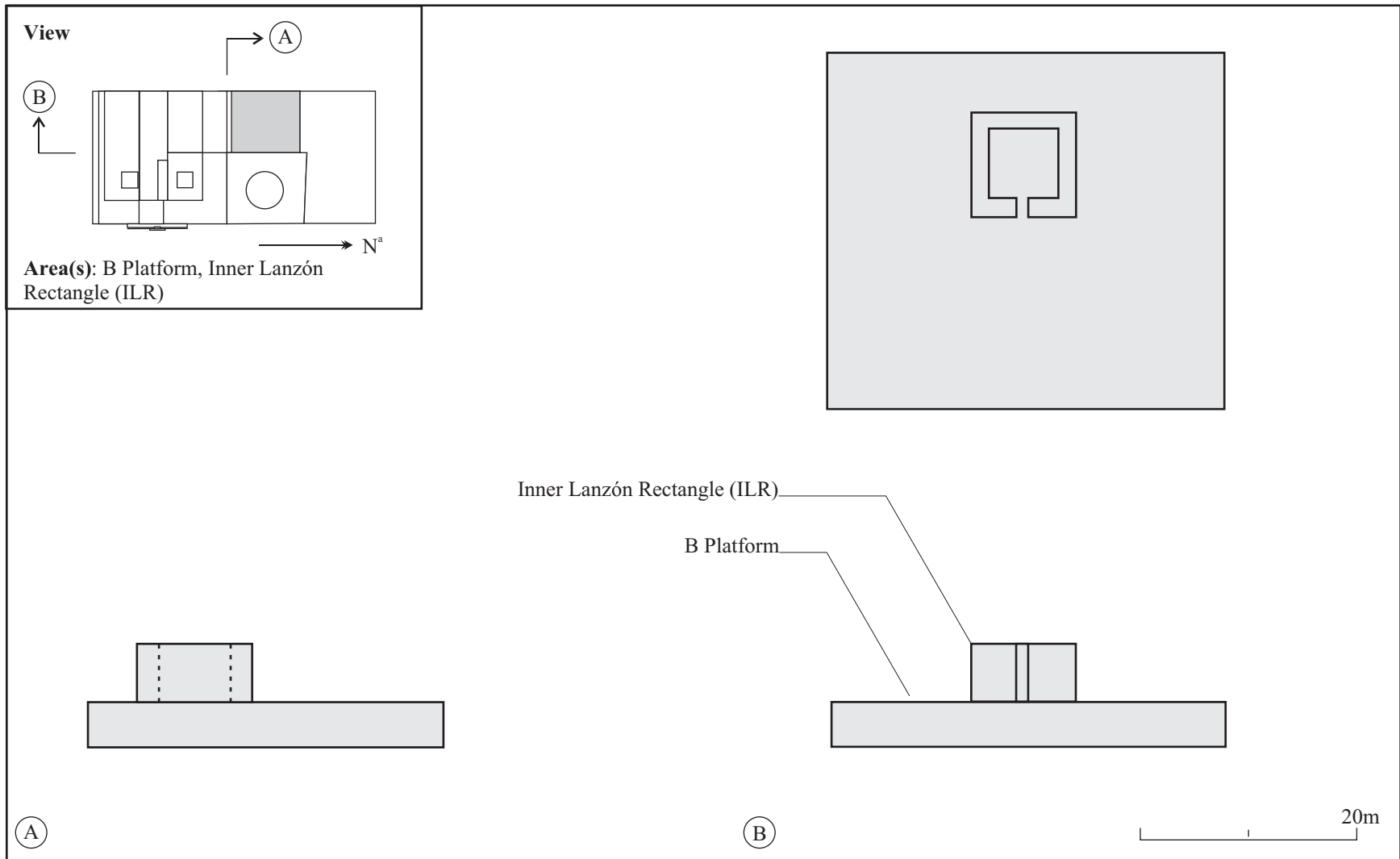

Figure 4.93. Building B Construction Phase 1: B Platform-ILR Phase.

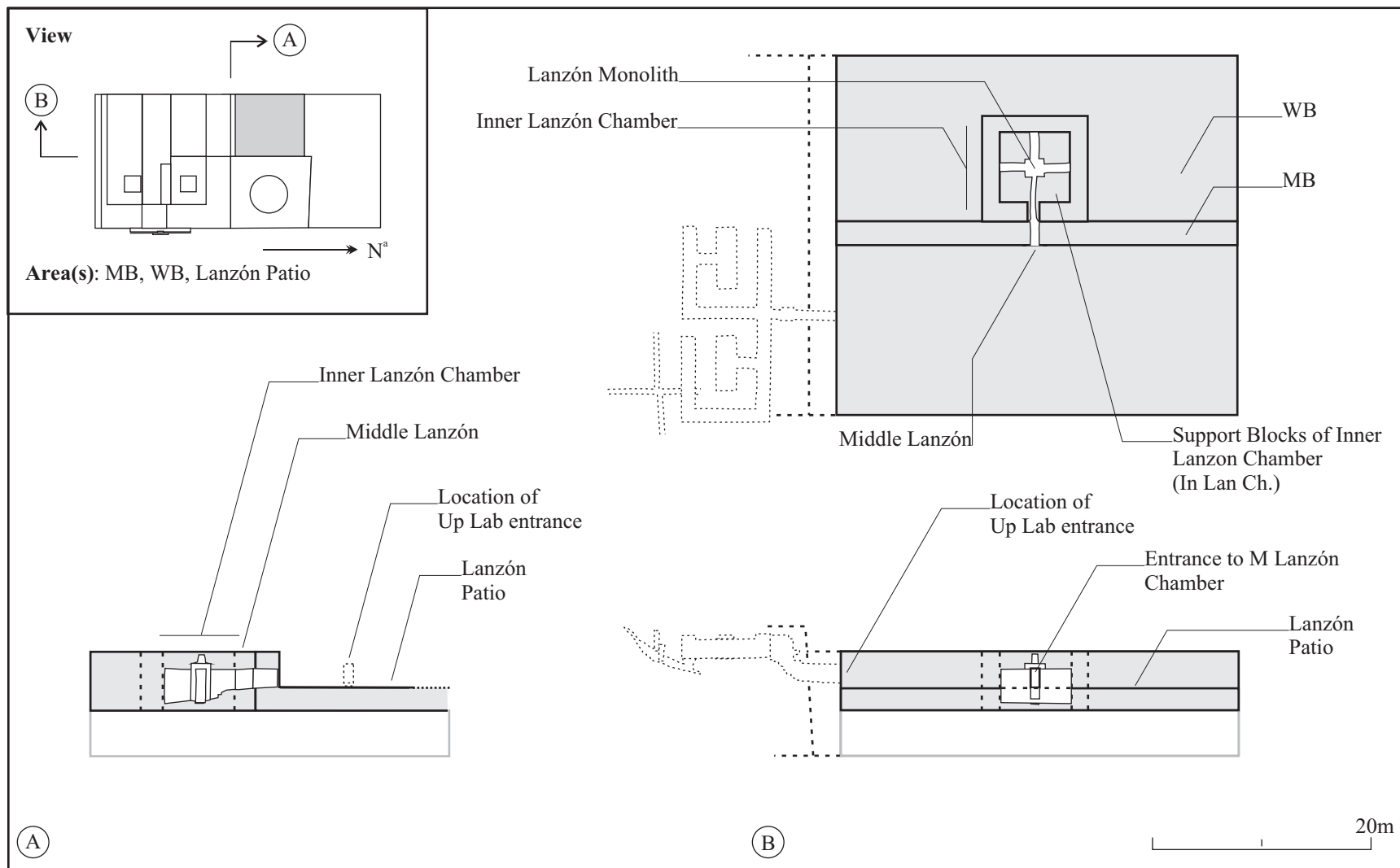

Figure 4.94. Building B Construction Phase 2: WB-MB Phase.

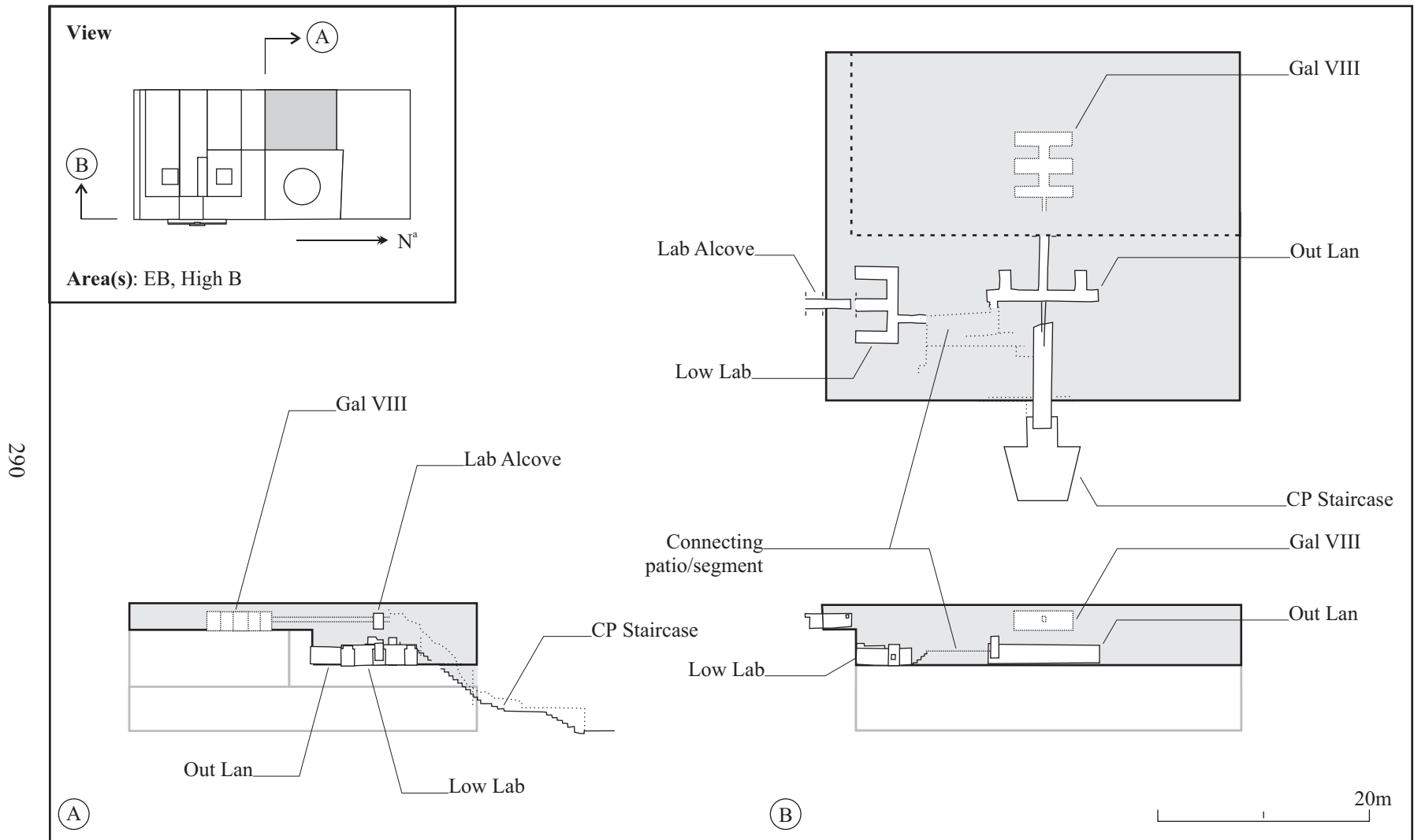

Figure 4.95. Building B Construction Phase 3: EB-High B Phase. CP Staircase not shown in view (B).

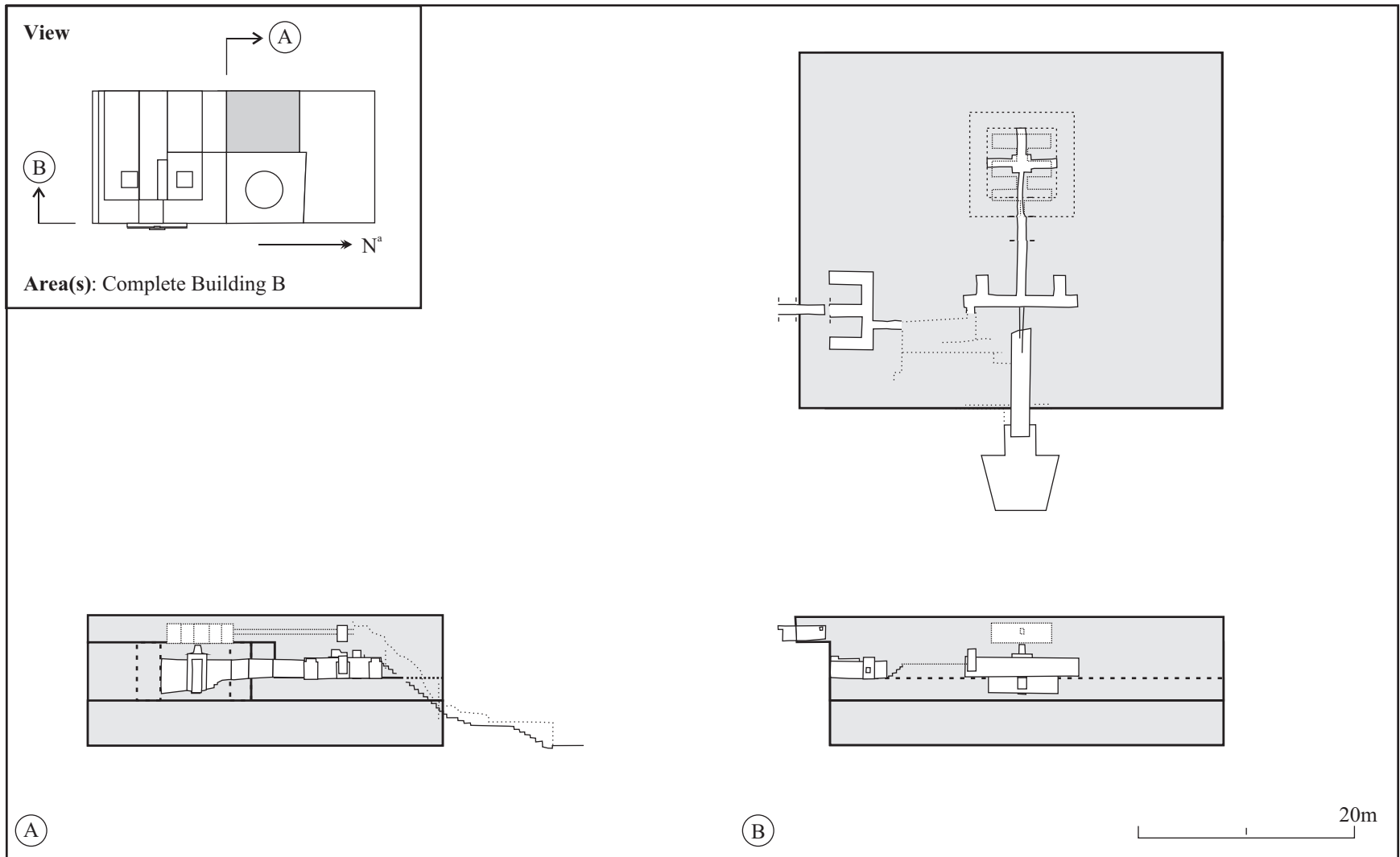

Figure 4.96. Building B Construction Phases: Full Sequence. CP Staircase not shown in view (B).

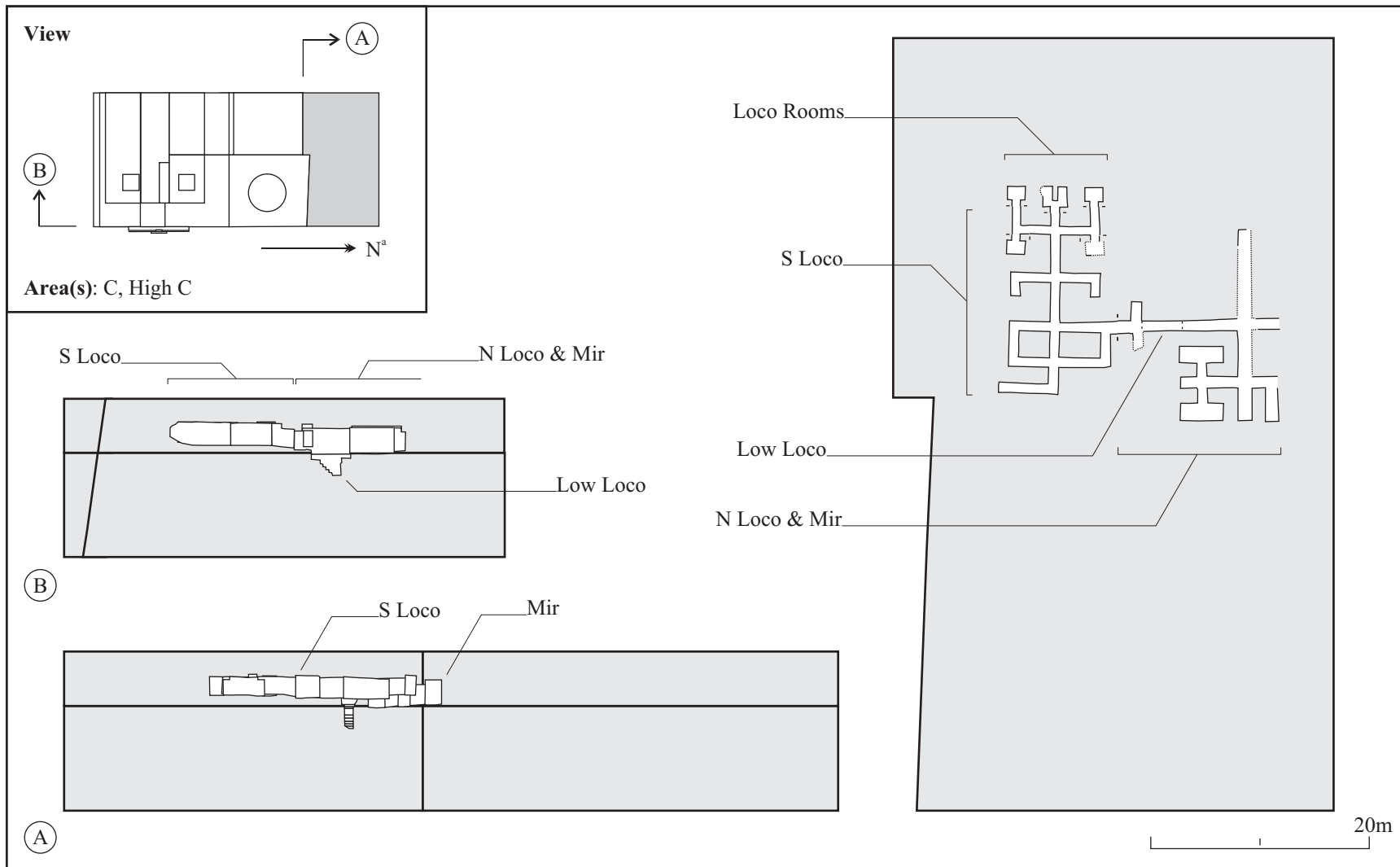

Figure 4.97. Building C area and galleries.

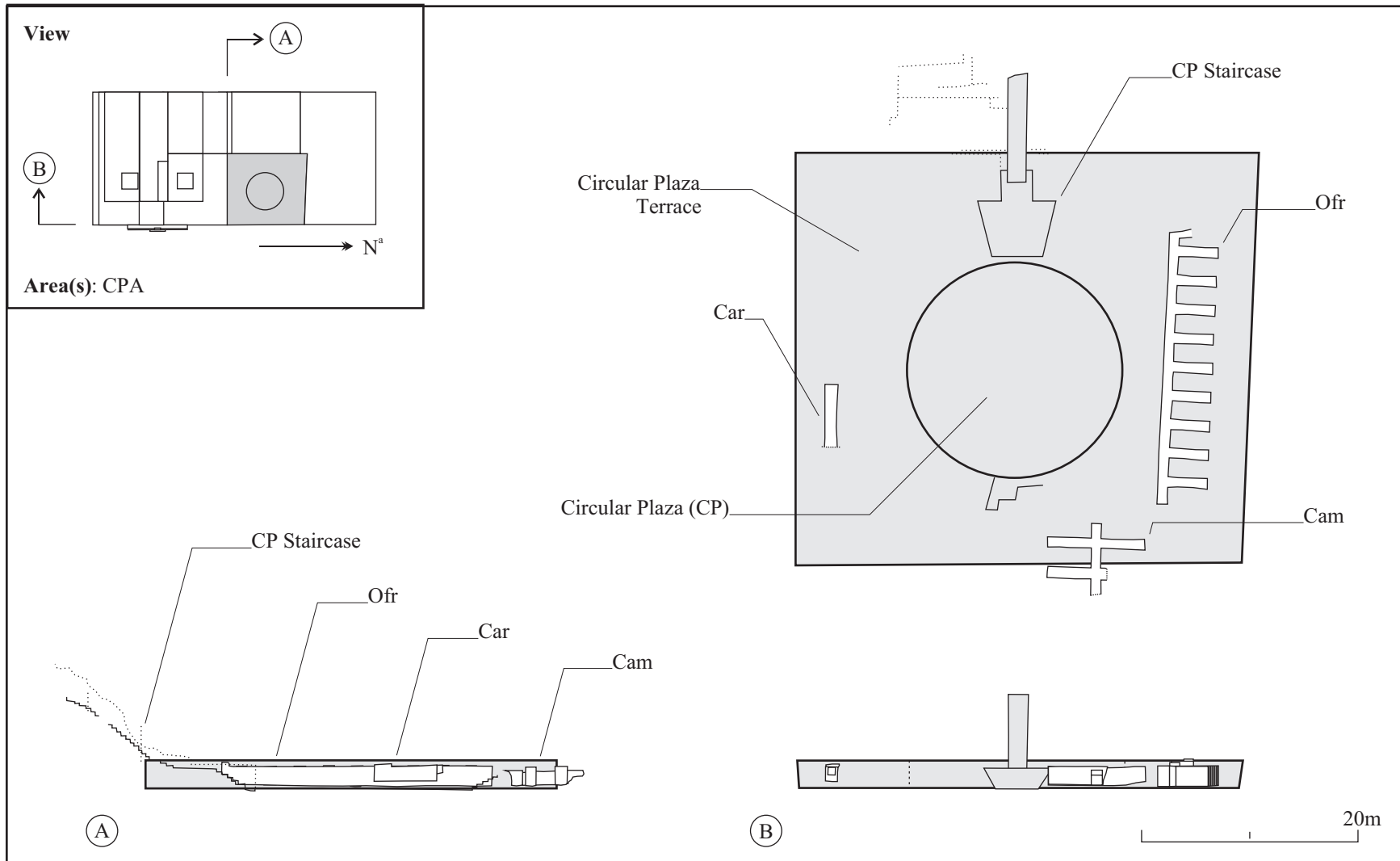

Figure 4.125. Circular Plaza Atrium (CPA) area and galleries.

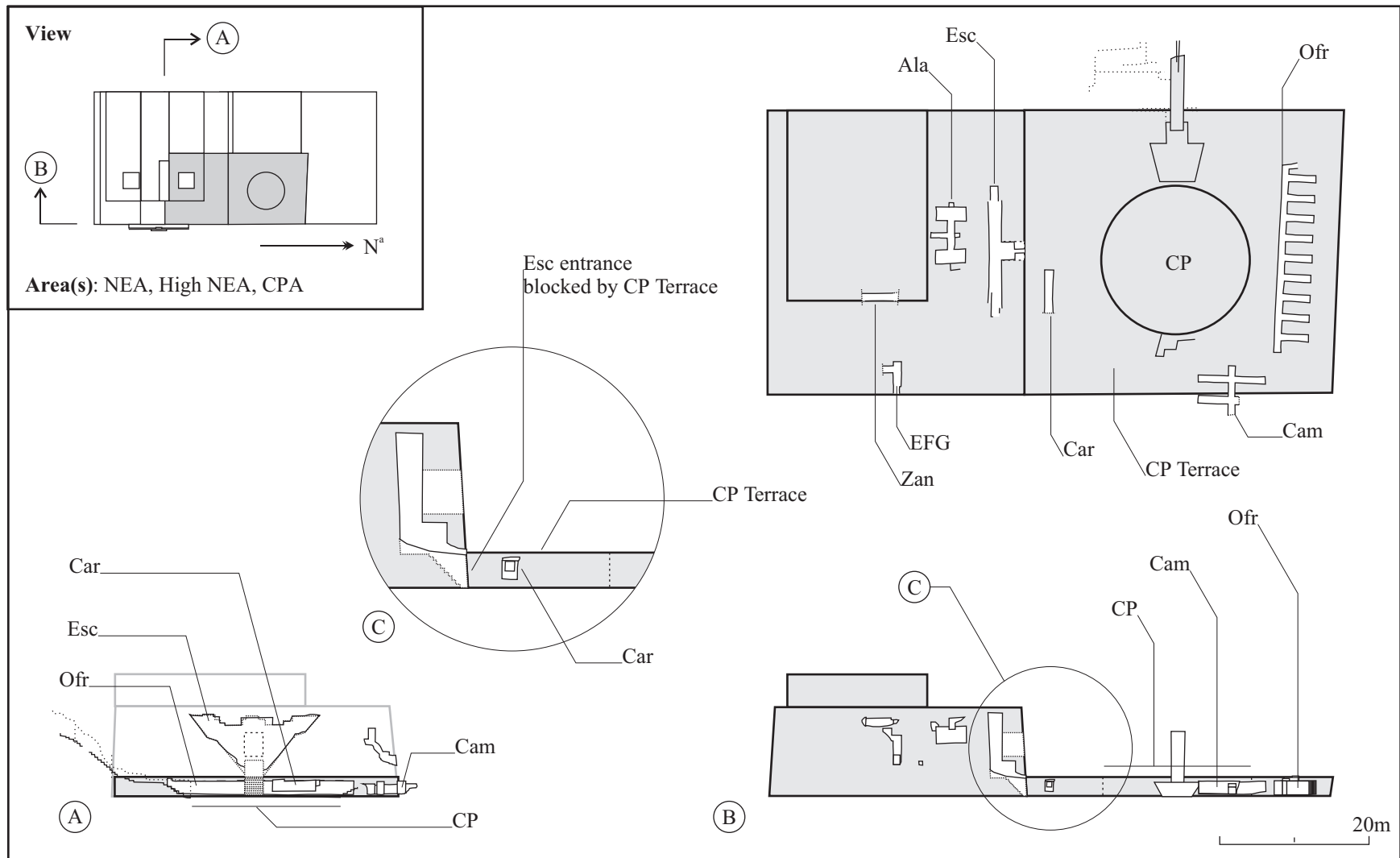

Figure 4.126. Circular Plaza Terrace blocks the entrance to Escalinata (Esc). Ala and Zan not shown in view (A).

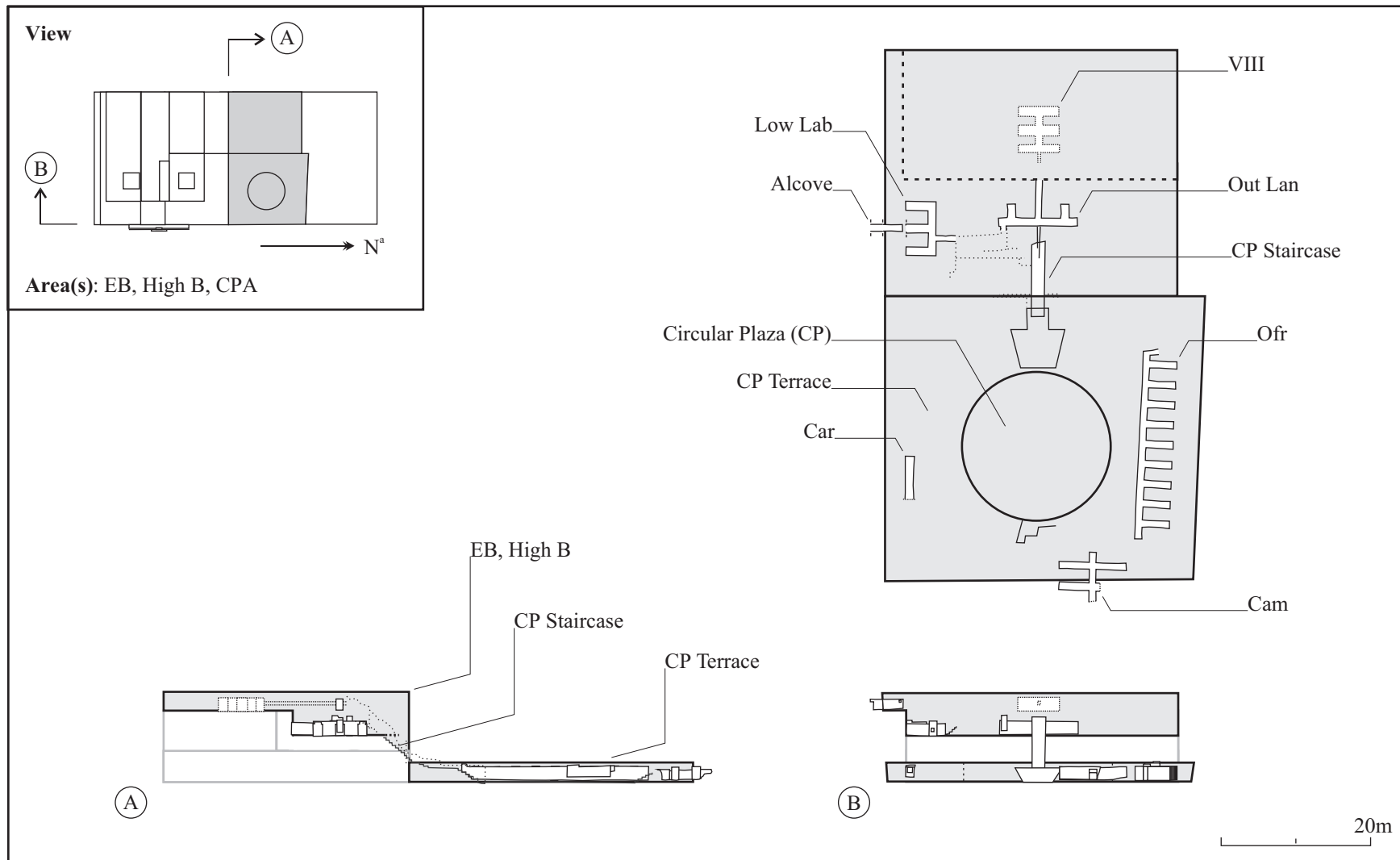

Figure 4.131. EB-High B-CPA Phase.

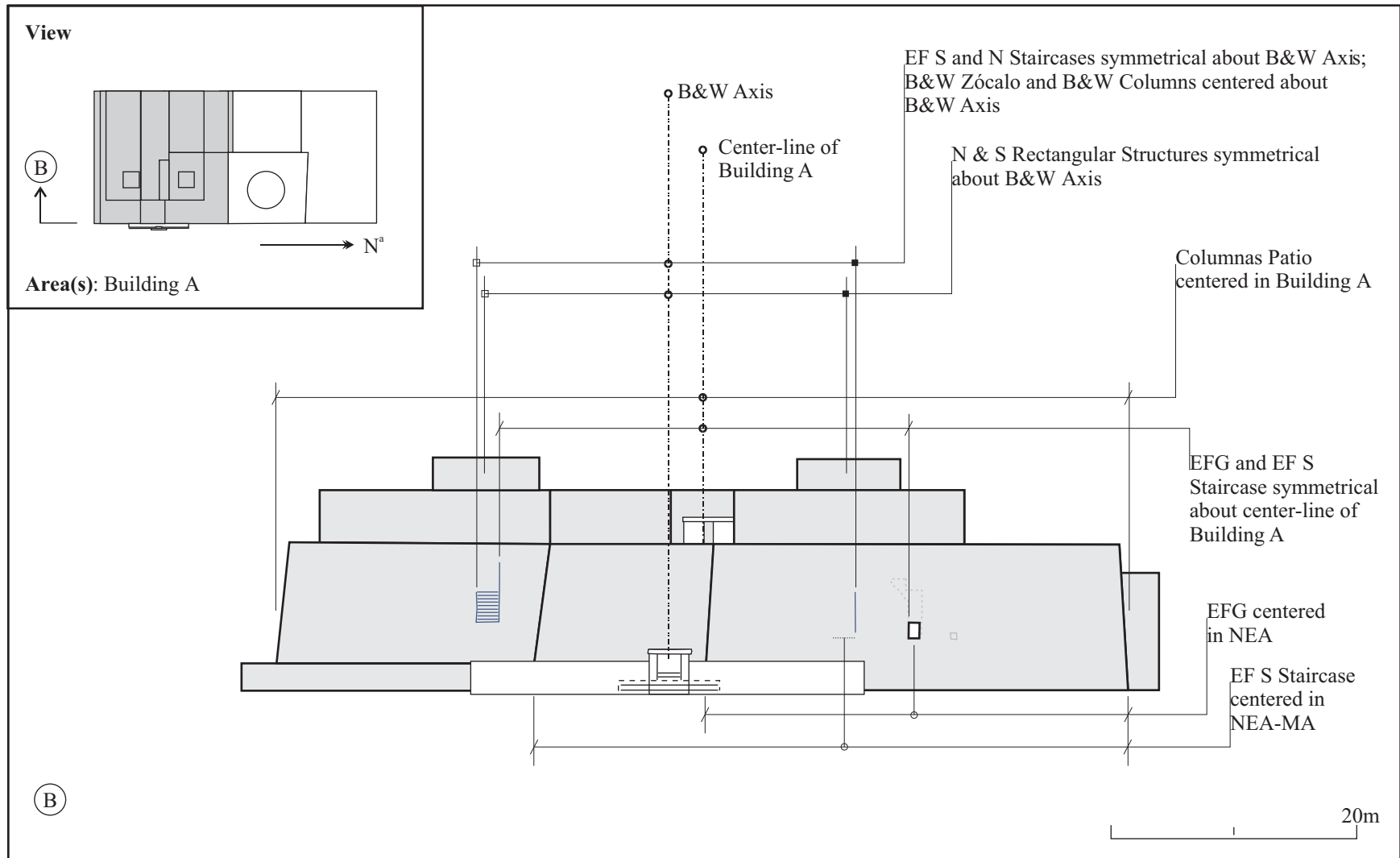

Figure 5.35. Centeredness and symmetry of staircases and architectural features within East Face of Building A.

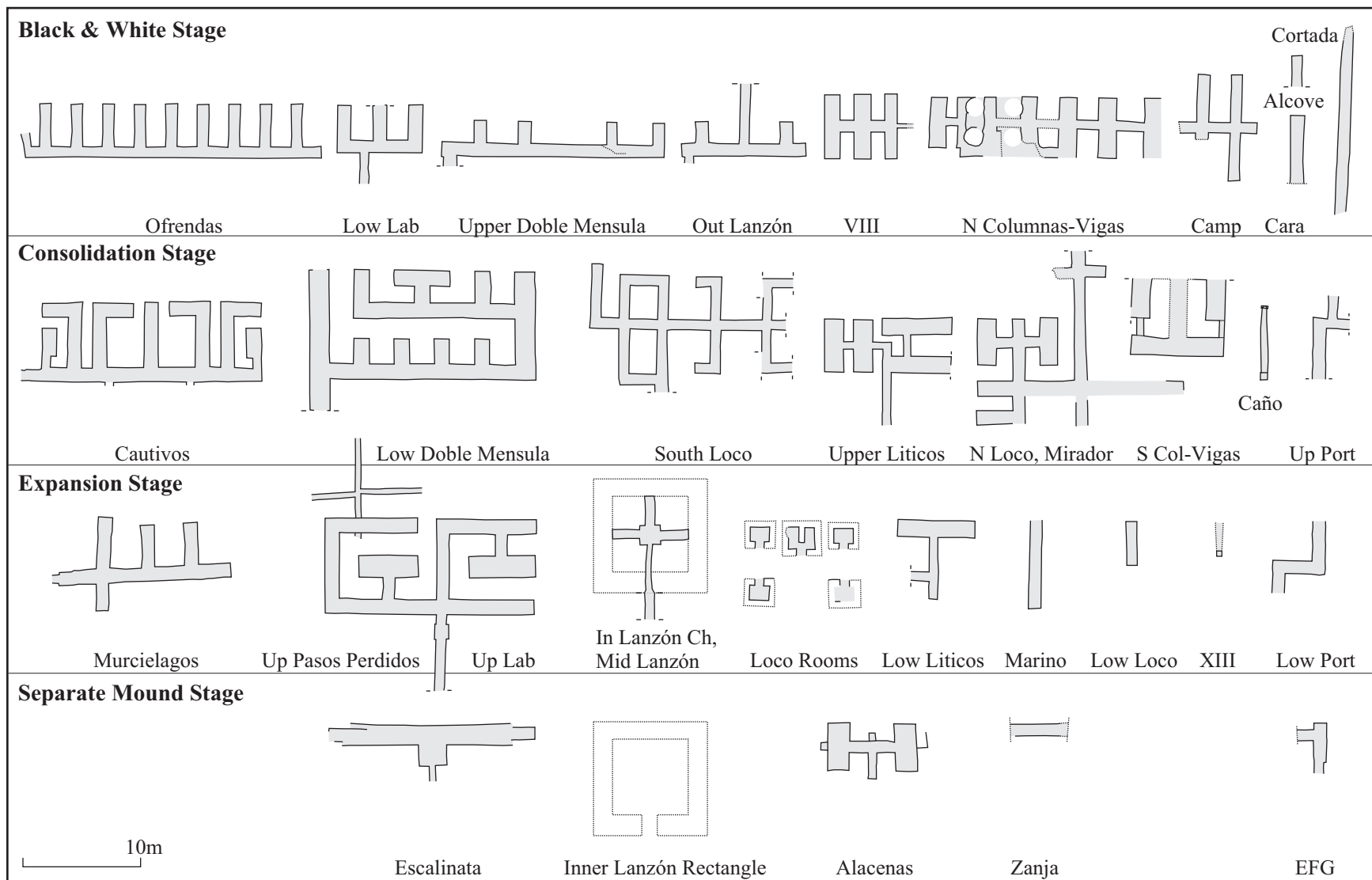

Figure 6.12. Standardization of gallery episode forms, by construction stage. Galleries drawn to scale from three-dimensional data.

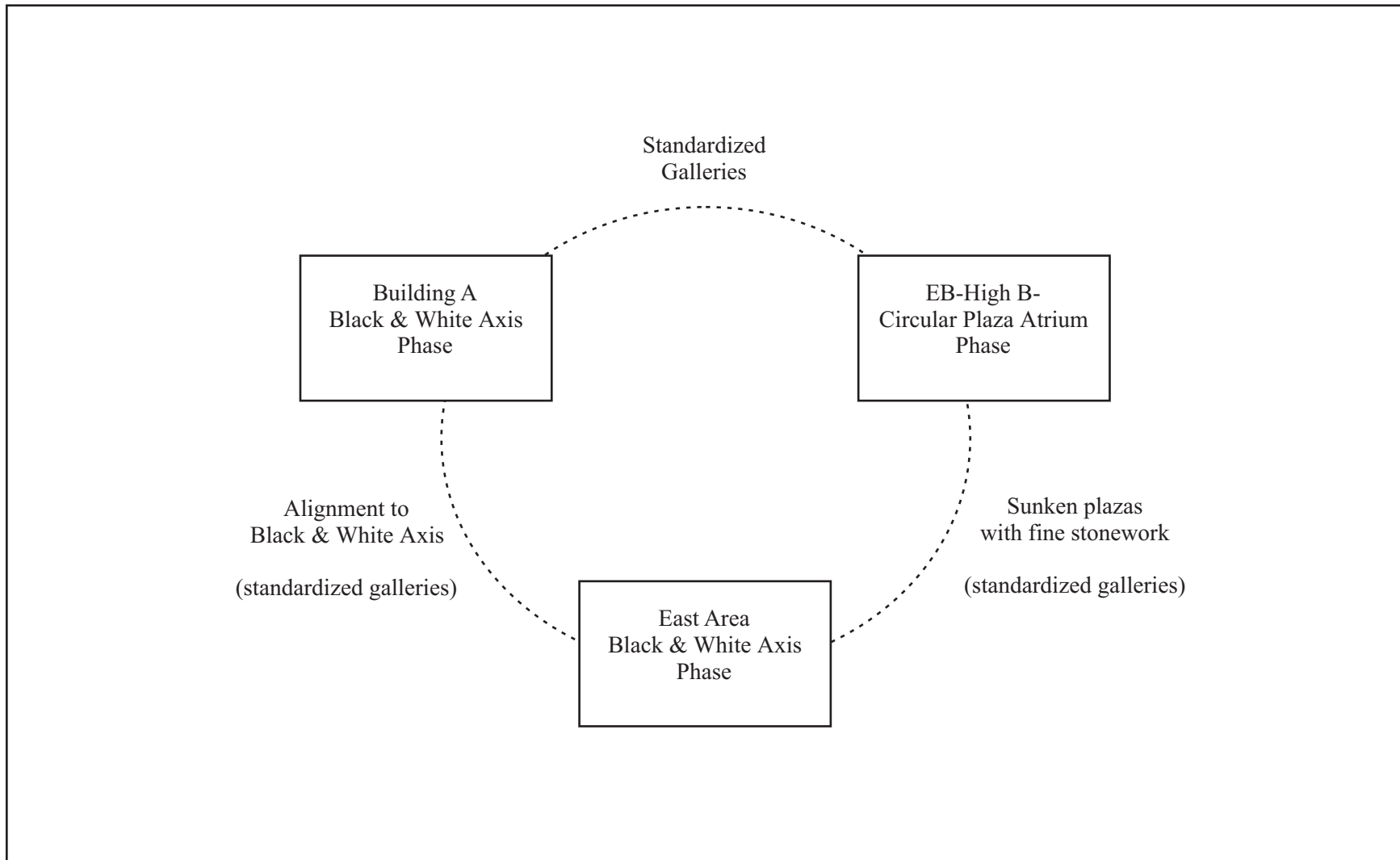

Figure 6.26. Architectural relationships between phases grouped within the Black & White Stage.

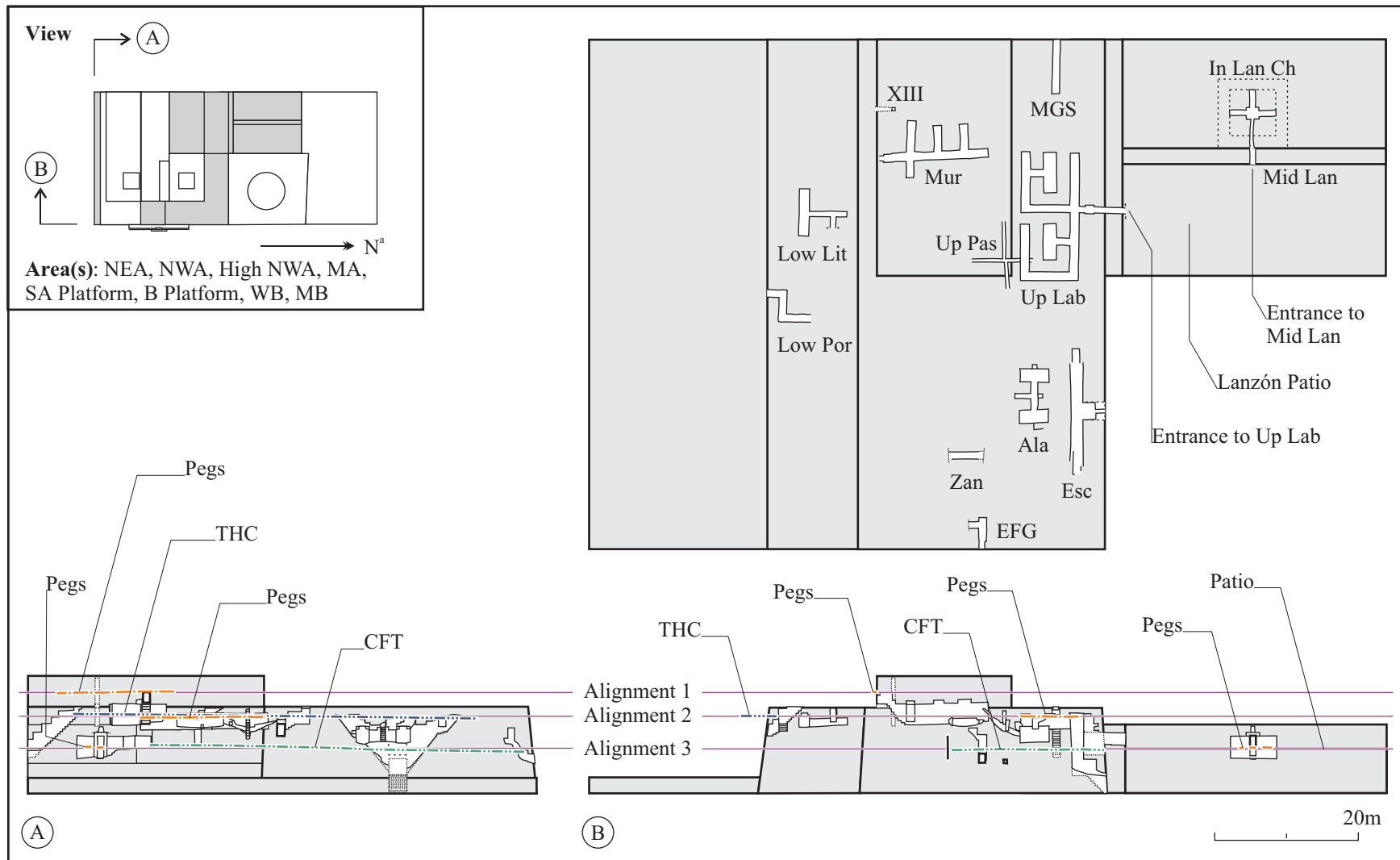

Figure 7.1. Phases in the Expansion Stage, with galleries and alignments of select architectural features. See Figures 7.2 and 7.3 for details of views (B) and (A).

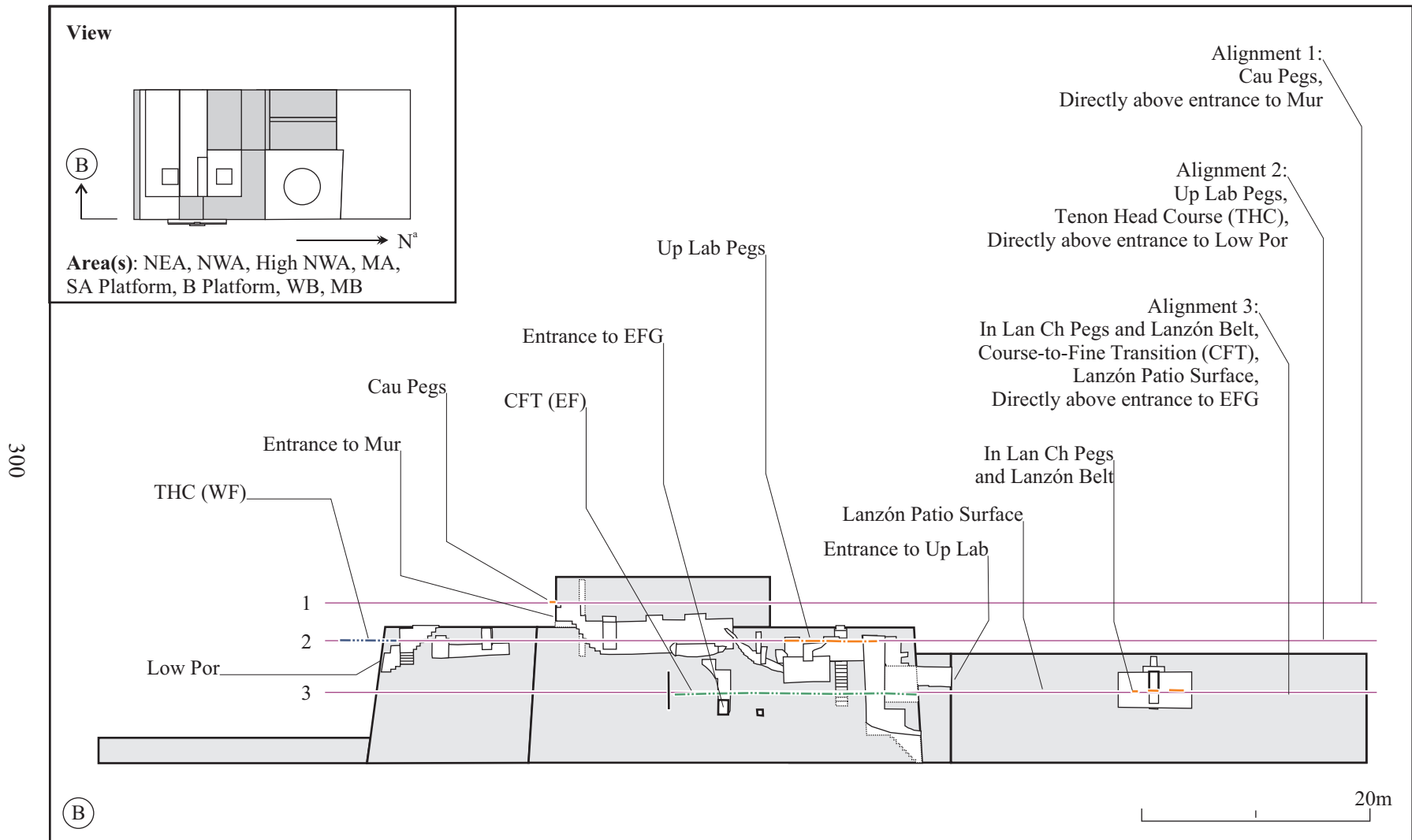

Figure 7.2. Phases in the Expansion Stage, with galleries and alignments of select architectural features. Detail view of Figure 7.1 view (B).

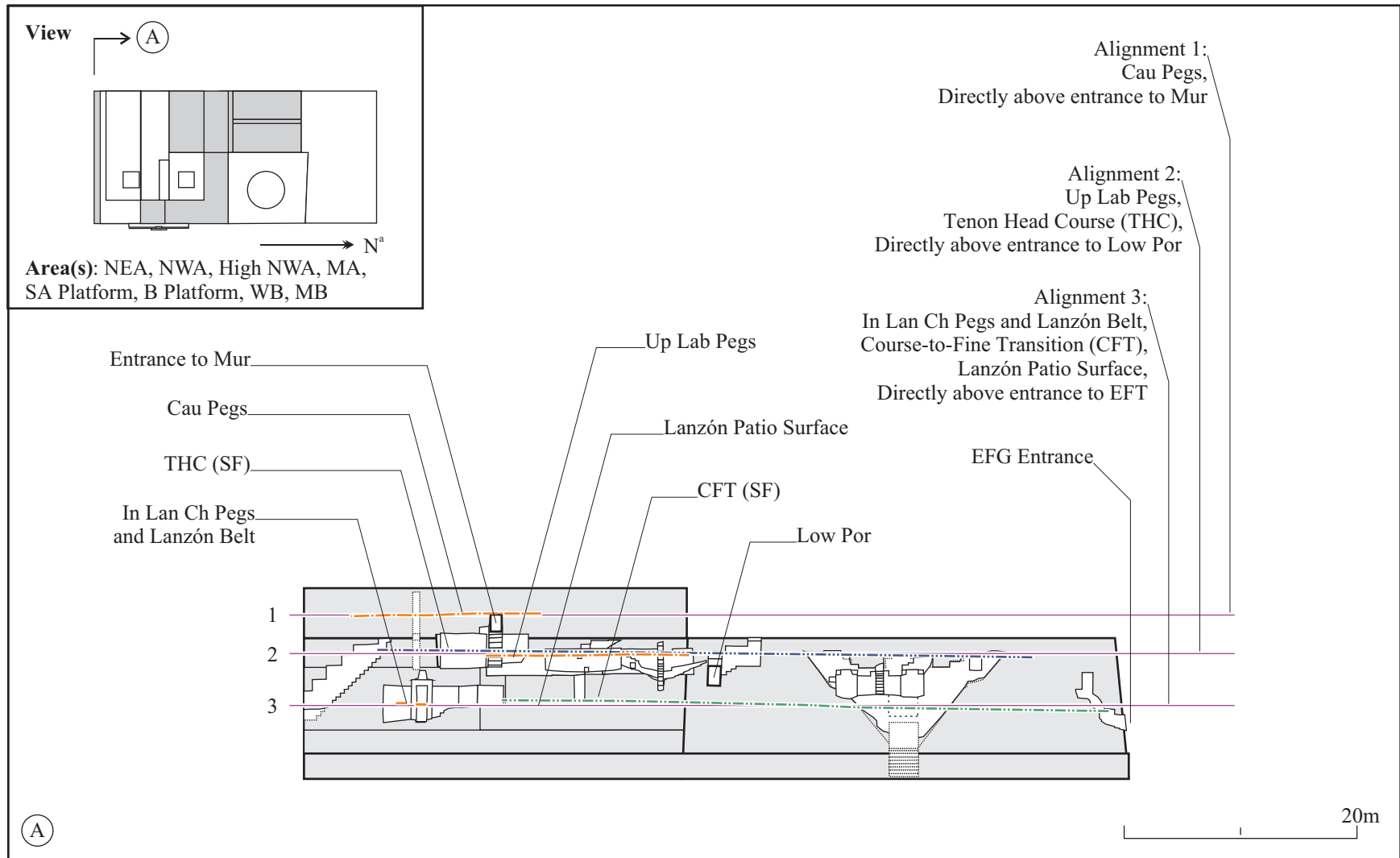

Figure 7.3. Phases in the Expansion Stage, with galleries and alignments of select architectural features. Detail view of Figure 7.1 view (A).

APPENDIX B. TABLES

Table 5.1. Centered staircases and doorways

| Door/Stairway | Face Centered Within | Distance (m) | Measurement Notes |
|---------------------------|------------------------------|---------------|---|
| East Face Gallery | East Face of NEA | 16.86 | South edge of doorway to south seam |
| | | 17.05 | North inside edge/wall to north corner |
| Escalinata Gallery | North Face of NEA | 18.48 | East edge to east corner ^a |
| | | 18.23 - 18.63 | West edge to estimated west corner ^b |
| East Face North Staircase | East Face of NEA-MA | 22.49 | North edge to north corner |
| | | 24.61 | South edge to south seam ^c |
| Lower Portada Entrance | South Face of MA | 35.40 | East edge to east face of temple |
| | | 35.90 | West edge to west face of temple |
| South Face Staircase | South Face of SA | 35.36 | East edge to east face of temple |
| | | 35.33 | West edge to west face of temple |
| Circular Plaza Staircase | East Face of Late Building B | 20.21 | South edge to north wall of Bldg A |
| | | 20.83 | North edge to south wall of Bldg C |
| Murcielagos Entrance | South Face of Murcielagos | 16.40 | West edge to west face |
| | Raised Platform | 16.37 | East edge to estimated Rowe's seam ^d |

^aE edge estimated; used inside edge

^bW edge estimated, used inside edge; W corner estimated by extending slope of buried A-N-1 seam down to this level

^cS edge assuming same width (1.85 m) as East Face South Staircase

^dA-N-1 seam estimated as extended south in model of NEA

Table 5.2. Symmetrical staircases

| Door/Stairway (pair) | Symmetrical About | Distance (m) | Measurement Notes |
|---------------------------|---|--------------|---|
| East Face Gallery | Building A East Face Midpoint (NEA-MA-SA) | 17.20 | South edge to East Face midpoint |
| East Face South Staircase | Building A East Face Midpoint (NEA-MA-SA) | 17.02 | North edge to East Face midpoint at CFT level |
| East Face North Staircase | Black & White Axis | 15.74 | North edge to Black & White Axis |
| East Face South Staircase | Black & White Axis | 15.94 | South edge to Black & White Axis |

Table 6.1. Initial construction sequence

| Building A | Building B & Circular Plaza Atrium | Building C | East Area |
|--|---|----------------------|---|
| Support construction | Support construction | Support construction | Support construction |
| Building A Black & White Axis Phase | EB-High B-CPA | High Building C | East Area Black & White Axis Phase |
| High SA | | | East Area Pre-Black & White Axis Phase |
| High MA | | | |
| SA | | | |
| High NEA | | | |
| NWA-High NWA-MA-SA Platform | | | WB-MB |
| NEA | B Platform-Inner Lanzón Rectangle | | |

Table 6.2. Initial gallery sequence

| Building A | Building B & Circular Plaza Atrium | Building C | East Area |
|--|--|--|---|
| Support construction | Support construction | Support construction | Support construction |
| Building A Black & White Axis Phase North Columnas-Vigas N & S Rectangular Structures | | | East Area Black & White Axis Phase |
| High SA Upper Doble Ménsula | | | Cortada Bennett "cells" (Building G Gallery) |
| High MA Cautivos, Upper Liticos, Upper Portada, South Columnas-Vigas, Columnas Patio | | | |
| SA Lower Doble Ménsula, Caño | EB-High B-CPA | High Building C | East Area Pre-Black & White Axis Phase |
| High NEA | Lower Laberintos, Lower Pasos Perdidos, Outer Lanzón, Circular Plaza Staircase, Laberintos Alcove, Gallery VIII Ofrendas, Campamento, Caracolas, Circular Plaza | South Loco, North Loco and Mirador, Loco Patio | Tello High, Tello Low, Rocas, Escondida |
| NWA-High NWA- MA-SA Platform Upper Laberintos, Upper Pasos Perdidos, Marino Gonzáles Staircase, Murciélagos, Gallery XIII, Lower Liticos, Lower Portada | WB-MB Inner Lanzón Chamber, Middle Lanzón, Lanzón Patio | Low Building C Lower Loco, Rooms of Loco | |
| NEA Escalinata, Alacenas, East Face Gallery and Vent, Zanja | B Platform-ILR Inner Lanzón Rectangle | | |

Table 6.3. Final gallery sequence

| Building A | Building B & Circular Plaza Atrium | Building C | East Area |
|---|--|--|--|
| Support construction | Support construction | Support construction | Support construction |
| <p>Building A Black & White Axis Phase</p> <p>North Columns-Vigas, N & S Rectangular Structures</p> | <p>EB-High B-CPA</p> <p>Lower Laberintos, Lower Pasos Perdidos, Outer Lanzón, Circular Plaza Staircase, Laberintos Alcove, Gallery VIII</p> <p>Ofrendas, Campamento, Caracolas, Circular Plaza</p> | | <p>East Area Black & White Axis Phase</p> <p>Cortada</p> <p>Bennett "cells" (Building G Gallery)</p> |
| <p>High SA</p> <p>Upper Doble Ménsula</p> | | | |
| <p>High MA</p> <p>Cautivos, Upper Liticos, Upper Portada, South Columns-Vigas, Columns Patio</p> | | <p>High Building C</p> <p>South Loco, North Loco and Mirador, Loco Patio</p> | <p>East Area Pre-Black & White Axis Phase</p> <p>Tello High, Tello Low, Rocas, Escondida</p> |
| <p>SA</p> <p>Lower Doble Ménsula, Caño</p> | | | |
| <p>High NEA</p> | | | |
| <p>NWA-High NWA- MA-SA Platform</p> <p>Upper Laberintos, Upper Pasos Perdidos, Marino Gonzáles Staircase, Murciélagos, Gallery XIII, Lower Liticos, Lower Portada</p> | <p>WB-MB</p> <p>Inner Lanzón Chamber, Middle Lanzón, Lanzón Patio</p> | <p>Low Building C</p> <p>Lower Loco, Rooms of Loco</p> | |
| <p>NEA</p> <p>Escalinata, Alacenas, East Face Gallery and Vent, Zanja</p> | <p>B Platform-ILR</p> <p>Inner Lanzón Rectangle</p> | | |

Table 6.4. Construction sequence for the monumental center at Chavín de Huántar

| Names for Grouped Phases | Building A | Building B & Circular Plaza Atrium | Building C | East Area |
|-----------------------------------|--|---|-------------------------|---|
| Support Construction Stage | Support construction | Support construction | Support construction | Support construction |
| Black & White Stage | Building A Black & White Axis Phase | EB-High B-CPA | | East Area Black & White Axis Phase |
| | High SA | | | |
| Consolidation Stage | High MA | | High Building C | East Area Pre-Black & White Axis Phase |
| | SA | | | |
| | High NEA | | | |
| Expansion Stage | NWA-High NWA-MA-SA Platform | WB-MB | ----- Low Building C | |
| Separate Mound Stage | NEA | B Platform-Inner Lanzón Rectangle ----- | ----- | |

Table 7.1. Radiocarbon dates associated with monumental architecture at Chavín de Huántar, Peru

| SAMPLE | PROVENANCE | UNCALIBRATED DATES | SOURCE |
|---------------|--|--------------------------------|----------------------|
| CdHCS-32 | Circular Plaza Atrium Level H | 2260 +/- 55 B.P. (310 B.C.) | Rick and Kembel 2000 |
| HAR-1105 | Circular Plaza Atrium Level H | 2380+/-70 B.P. (430 B.C.) | Lumbreras 1993 |
| CdHCS-33 | Circular Plaza Atrium Level H | 2395 +/- 55 B.P. (445 B.C.) | Rick and Kembel 2000 |
| CdHCS-29 | Building A West Face South Seam (A-W-1) | 2455 +/-55 B.P. (505 B.C.) | Rick and Kembel 2000 |
| CdHCS-11 | Building A East Face Black & White Zócalo North Seam (A-E-1) | 2640 +/-55 B.P. (690 B.C.) | Rick and Kembel 2000 |
| CdHCS-12 | Building A East Face Black & White Zócalo North Seam (A-E-1) | 2695 +/-55 B.P. (745 B.C.) | Rick and Kembel 2000 |
| GX-1128 | Ofrendas Gallery | 2700+/-85 B.P. (750 B.C.) | Lumbreras 1993 |
| TK-18 | Ofrendas Gallery | 3050+/-120 B.P. (1100 B.C.) | Lumbreras 1993 |

Table 7.2. Summary of revised construction sequence and associated radiocarbon dates

| RADIOCARBON DATES ASSOCIATED WITH MONUMENTAL ARCHITECTURE AT CHAVIN DE HUANTAR | | | REVISED ARCHITECTURAL SEQUENCE FOR CHAVIN DE HUANTAR | |
|--|--|-------------------------------|--|------------------------------|
| SAMPLE | PROVENANCE | UNCALIBRATED DATES | GROUPED PHASES | HIGH-LEVEL PATTERN |
| CdHCS-32 | Circular Plaza Atrium Level H | 2260 +/- 55 B.P. (310 B.C.) | SUPPORT CONSTRUCTION STAGE | POST-MONUMENTAL CONSTRUCTION |
| HAR-1105 | Circular Plaza Atrium Level H | 2380 +/- 70 B.P. (430 B.C.) | | |
| CdHCS-33 | Circular Plaza Atrium Level H | 2395 +/- 55 B.P. (445 B.C.) | | |
| CdHCS-29 | Building A West Face South Seam (A-W-1) | 2455 +/- 55 B.P. (505 B.C.) | | |
| CdHCS-11 | Building A East Face Black & White Zócalo North Seam (A-E-1) | 2640 +/- 55 B.P. (690 B.C.) | BLACK & WHITE STAGE | MONUMENTAL CONSTRUCTION |
| CdHCS-12 | Building A East Face Black & White Zócalo North Seam (A-E-1) | 2695 +/- 55 B.P. (745 B.C.) | | |
| GX-1128 | Ofrendas Gallery | 2700 +/- 85 B.P. (750 B.C.) | | |
| TK-18 | Ofrendas Gallery | 3050 +/- 120 B.P. (1100 B.C.) | | |
| | | | CONSOLIDATION STAGE | |
| | | | EXPANSION STAGE | |
| | | | SEPARATE MOUND STAGE | |

Table 7.3. Sequence comparison based on the three-phase construction sequence by Rowe (1967)

| RADIOCARBON DATES ASSOCIATED WITH ARCHITECTURE | | | ARCHITECTURE SEQUENCE- ROWE 1967 | ART PHASES ANCHORED IN ARCHITECTURE SEQUENCE- ROWE 1967 | CERAMIC SEQUENCE- BURGER 1984 | CERAMIC SEQUENCE- LUMBRERAS 1989 |
|--|----------------------------------|---------------------------------------|-------------------------------------|---|----------------------------------|--|
| SAMPLE | PROVENANCE | UNCALBRATED DATES | | | | |
| HAR-1105 | Circular Plaza Atrium Level H | 2380+/-70 B.P. (430 B.C.) | NEW TEMPLE (SECOND ADDITION) | PHASE D | JANABARRIU (390-200 B.C.) | JANABARRIU AND CHAKINANI (600-200 B.C.) |
| | | | FIRST ADDITION | | CHAKINANI (460-390 B.C.) | |
| GX-1128 | Ofrendas Gallery | 2700+/-85 B.P. (750 B.C.) | OLD TEMPLE | PHASE AB | URABARRIU (850-460 B.C.) | OFRENDAS |
| TK-18 | Ofrendas Gallery | 3050+/-120 B.P. (1100 B.C.) | | | | AND URABARRIU (1200-600 B.C.) |

Table 7.4. Sequence comparison based on revised architectural sequence

| RADIOCARBON DATES ASSOCIATED WITH ARCHITECTURE | | | REVISED ARCHITECTURAL SEQUENCE | | ART PHASES ANCHORED IN ARCHITECTURE SEQUENCE- ROWE 1967 | CERAMIC SEQUENCE- BURGER 1984 | CERAMIC SEQUENCE- LUMBRERAS 1989 |
|--|--|-------------------------------|--------------------------------|------------------------------|---|-------------------------------|----------------------------------|
| SAMPLE | PROVENANCE | UNCALBRATED DATES | GROUPED PHASES | HIGH-LEVEL PATTERN | | | |
| CdHCS-32 | Circular Plaza A trium Level H | 2260 +/- 55 B.P. (310 B.C.) | SUPPORT CONSTRUCTION STAGE | POST-MONUMENTAL CONSTRUCTION | | JANABARRIU (390-200 B.C.) | JANABARRIU AND |
| HAR-1105 | Circular Plaza A trium Level H | 2380 +/- 70 B.P. (430 B.C.) | | | | AND | CHAKINANI |
| CdHCS-33 | Circular Plaza A trium Level H | 2395 +/- 55 B.P. (445 B.C.) | | | | CHAKINANI | |
| CdHCS-29 | Building A West Face South Seam (A-W-1) | 2455 +/- 55 B.P. (505 B.C.) | | | | (460-390 B.C.) | (600-200 B.C.) |
| CdHCS-11 | Building A East Face Black & White Zócalo North Seam (A-E-1) | 2640 +/- 55 B.P. (690 B.C.) | BLACK & WHITE STAGE | MONUMENTAL CONSTRUCTION | | | OFRENDAS |
| CdHCS-12 | Building A East Face Black & White Zócalo North Seam (A-E-1) | 2695 +/- 55 B.P. (745 B.C.) | | | | | |
| GX-1128 | Ofrendas Gallery | 2700 +/- 85 B.P. (750 B.C.) | | | | | AND |
| TK-18 | Ofrendas Gallery | 3050 +/- 120 B.P. (1100 B.C.) | | | | | |
| | | | CONSOLIDATION STAGE | | | URABARRIU (850-460 B.C.) | URABARRIU (1200-600 B.C.) |
| | | | EXPANSION STAGE | | | | |
| | | | SEPARATE MOUND STAGE | | | | |

BIBLIOGRAPHY

- Bennett, W. C.
1942 Chavín stone carving. *Yale Anthropological Studies* 3.
- 1944 The North Highlands of Peru: Excavations in the Callejón de Huaylas and at Chavín de Huántar. *Anthropological Papers of the American Museum of Natural History* Volume 39: Part 1, New York.
- Bischof, H.
1994 Toward the Definition of Pre- and Early Chavín Art Styles in Peru. *Andean Past* 4:169-228.
- Burger, R. L.
1981 The Radiocarbon Evidence for the Temporal Priority of Chavín de Huántar. *American Antiquity*:592-602
- 1984 The Prehistoric Occupation of Chavín de Huántar, Peru. *University of California Publications in Anthropology* 14. University of California Press, Berkeley.
- 1985 Concluding Remarks: Early Peruvian Civilization and its Relation to the Chavín Horizon. In *Early Ceremonial Architecture in the Andes*, edited by C. B. Donnan, pp. 269-289. *Dumbarton Oaks*, Washington, D.C.
- 1988 Unity and Heterogeneity within the Chavín Horizon. In *Peruvian Prehistory*, edited by R. Keatinge, pp. 99-144. *Cambridge University Press*, Cambridge.
- 1992 *Chavín and the Origins of Andean Civilization*. *Thames and Hudson Ltd*, London.
- 1993 The Chavín Horizon: Stylistic Chimera or Socioeconomic Metamorphosis? In *Latin American Horizons*, edited by D. S. Rice, pp. 41-82. *Dumbarton Oaks*, Washington, D.C.
- Burger, R. L. and L. Salazar-Burger
1985 The Early Ceremonial Center of Huaricoto. In *Early Ceremonial Architecture in the Andes*, edited by C. Donnan, pp. 111-138. *Dumbarton Oaks Research Library and Collection*, Washington.
- Chávez Ballón, M.
1960 Informe Sobre Los Restos Arqueologicos Y Los Trabajos Que Se Realizan de Las Ruinas de Chavín, Provincia de Huari, Departamento de Ancash, Cuzco.
- Conklin, W. J.
1985 The Architecture of Huaca Los Reyes. In *Early Ceremonial Architecture in the Andes*, edited by C. Donnan, pp. 139-164. *Dumbarton Oaks Research Library and Collection*, Washington.

- Diessl, W. G.
1989 Informe: Templo Formativo de Chavín: Excavación en la Galería "El Loco" en 1989.
- Gonzáles, M. and R. M. Rick
1995-1998 Videotape interviews of Marino Gonzáles regarding his work at Chavín de Huántar. Tapes in possession of R.M. Rick and S. R. Kembel.
- Grieder, T. and A. Bueno Mendoza
1985 Ceremonial Architecture at La Galgada. In *Early Ceremonial Architecture in the Andes*, edited by C. Donnan, pp. 93-110. *Dumbarton Oaks Research Library and Collection*, Washington.
- Grieder, T., A. Bueno Mendoza, C. E. Smith Jr. and R. M. Malina
1988 *La Galgada: A Preceramic Culture in Transition*. University of Texas Press, Austin.
- Inokuchi, K.
1998 La cerámica de Kuntur Wasi y el problem Chavín. In *Perspectivas Regionales del Período Formativo en el Perú*, edited by P. Kaulicke, pp. 161-180. *Boletín de Arqueología PUCP*. vol. 2. Pontificia Universidad Católica del Perú, Lima.
- Isbell, W. H.
1976 *Cosmological Order Expressed in Prehistoric Ceremonial Centers*. *Actes du XLII Congrés International des Americanistes IV:269-299*.
- Izumi, S.
1971 Development of the Formative Culture in the Ceja de Montana of the Central Andes. In *Dumbarton Oaks Conference on Chavín*, edited by E. Benson, pp. 49-72. *Dumbarton Oaks Research Library and Collection*, Washington.
- Izumi, S. and T. Sono
1963 *Andes 2: Excavations at Kotosh, Peru, 1960*. Kadokawa Publishing Co., Tokyo.
- Izumi, S. and K. Terada
1972 *Excavations at Kotosh, Peru: A Report on the Third and Fourth Expeditions*. University of Tokyo Press.
- Kaufmann Doig, F. and M. G. Moreno
1993 24 Planos Arquitectónicos de Chavín de Huántar. *Arqueológicas* 22. Instituto de Investigaciones Antropológicas, Lima.
- Kubler, G.
1975 *The Art and Architecture of Ancient America: The Mexican/Maya/and Andean peoples*. Second ed. *Pelican History of Art*. Penguin Books, Great Britain.
- Lumbreras, L. G.
1970 *Los Templos de Chavín. Guía de Monumentos y Exposiciones* 1. Museo de Arqueología y Etnología de la Universidad Nacional Mayor de San Marcos, Lima.

- 1971 Towards a Re-evaluation of Chavín. In *Dumbarton Oaks Conference on Chavín*, edited by E. Benson, pp. 1-28. Dumbarton Oaks Research Library and Collection, Washington.
- 1974 Informe de labores del Proyecto Chavín, pp. 37-56. *Arqueológicas*. vol. 15. Museo Nacional de Antropología y Arqueología, Lima.
- 1974b *The Peoples and Cultures of Ancient Peru*. Smithsonian Institution Press, Washington, D. C.
- 1977 Excavaciones en el templo antiguo de Chavín (sector R): informe de la sexta campaña. *Ñawpa Pacha* 15:1-38.
- 1989 *Chavín de Huántar en el Nacimiento de la Civilización Andina*. Instituto Andino de Estudios Arqueológicos, Lima, Peru.
- 1993 *Chavín de Huántar: Excavaciones en la Galería de las Ofrendas*. *Materialien zur Allgemeinen und Vergleichenden Archaologie* bd. 51. P. von Zabern, Mainz Am Rhein.
- Lumbreras, L. G. and H. Amat Olazabal
1965-66 Informe Preliminar Sobre Las Galerías Interiores de Chavín (Primera temporada de trabajos). *Revista del Museo Nacional* 34 (1965-1966):143-197.
- Lumbreras, L.G., C. González and B. Lietaer
1976 Acerca de la función del sistema hidráulico de Chavín. *Museo Nacional de Antropología y Arqueología*. Lima.
- Miller, G. R. and R. L. Burger
1995 Our Father the Cayman, Our Dinner the Llama: Animal Utilization at Chavín de Huántar, Peru. *American Antiquity* 60(3):421-458.
- Moore, J. D.
1996 *Architecture and Power in the Ancient Andes: The Archaeology of Public Buildings*. *New Studies in Archaeology*. Cambridge University Press, Cambridge.
- Morales, D.
1988 Investigaciones arqueológicas en Pacopampa, departamento de Cajamarca. In *Perspectivas Regionales del Período Formativo en el Perú*, edited by P. Kaulicke, pp. 113-126. *Boletín de Arqueología PUCP*. vol. 2. Pontificia Universidad Católica del Perú, Lima.
- Moseley, M. E.
1975 *The Maritime Foundations of Andean Civilization*. Cummings Publishing Co., Menlo Park, CA.
- 1985 The Exploration and Explanation of Early Monumental Architecture in the Andes. In *Early Ceremonial Architecture in the Andes*, edited by C. Donnan, pp. 29-58. Dumbarton Oaks Research Library and Collection, Washington.
- 1992 *Incas and Their Ancestors: The Archaeology of Peru*. Thames and Hudson, London.

- Moseley, M. E., R. A. Feldman and C. R. Ortloff
 1981 Living with Crises: Human Perception of Process and Time. In *Biotic Crises in Ecological and Evolutionary Time*, edited by M. H. Nitecki, pp. 231-268. Academic Press, New York.
- Nials, F. L., E. E. Deeds, M. E. Moseley, S. G. Pozorski, T. G. Pozorski and R. Feldman
 1979 El Niño: the catastrophic flooding of coastal Peru, pt 2. *Field Museum of Natural History Bulletin* 50(8):4-10.
- Pozorski, T. and S. Pozorski
 1987 Chavín, the Early Horizon and the Initial Period. In *The Origins and Development of the Andean State*, edited by J. Haas, S. Pozorski and T. Pozorski, pp. 36-46. Cambridge University Press, Cambridge.
- Renfrew, C. and P. Bahn
 1991 *Archaeology: Theories, Methods, and Practice*. Thames and Hudson, London.
- Rick, J. and S. R. Kembel
 2000 Excavations and Chronology at the Monumental Center of Chavín de Huántar, Perú. Paper presented at the Paper presented at the 65th Annual Meeting of the Society for American Archaeology, April 7, 2000, Philadelphia, PA.
- Rick, J., S. R. Kembel, R. M. Rick and J. A. Kembel
 1998 La Arquitectura del Complejo Ceremonial de Chavín de Huántar: Documentación Tridimensional y Sus Implicancias. In *Perspectivas Regionales del Período Formativo en el Perú*, edited by P. Kaulicke, pp. 181-214. *Boletín de Arqueología PUCP*. vol. 2. Pontificia Universidad Católica del Perú, Lima.
- Rick, J. W.
 1996 The Use of Laser Tools in Archaeology. *Society of American Archaeology Bulletin* 14(2 March/April):8-10.
- Roe, P.
 1983 Recent Discoveries in Chavín Art: Some Speculations on Methodology and Significance in the Analysis of a Figural Style. In *Chavín Art*. *Museum of Anthropology miscellaneous series*. vol. 48. University of Northern Colorado, Greeley, CO.
- Roosevelt, C. V. S.
 1935 Ancient Civilizations of the Santa Valley and Chavín. *The Geographical Review* XXV:21-42.
- Rosas, H. and R. Shady
 1974 Sobre el período Formativo en la sierra del extremo norte del Perú, pp. 6-36. *Arqueológicas*. vol. 15. Museo Nacional de Antropología y Arqueología, Lima.
- Rowe, J. H.
 ms.a Libreta de Apuntes - Field Notes, 1961, Number 3. Chavín:1-139.
 ms.b Libreta de Apuntes - Field Notes, 1963, Number 4. Chavín:1-159.

- 1962 Chavín Art, An Inquiry Into Its Form and Meaning. University Publishers, New York.
- 1967 Form and Meaning in Chavín Art. In *Peruvian Archaeology: Selected Readings*, edited by J. H. Rowe and D. Menzel, pp. 72-103. Peek Publications, Palo Alto.
- 1971 The Influence of Chavín Art on Later Styles. In *Dumbarton Oaks Conference on Chavín*, edited by E. Benson, pp. 101-124. Dumbarton Oaks Research Library and Collection, Washington.
- Saffer, S.
1998 The tenon heads of Chavín de Huántar: Evidence for drug use at a pre-historic temple site. Undergraduate Honors Thesis, Stanford University.
- Schreiber, K.
1978 Planned Architecture of Middle Horizon Peru: Implications for Social and Political Organization. Ph.D. Dissertation. University of New York at Binghamton.
- Seki, Y.
1998 El Período Formativo en el valle de Cajamarca. In *Perspectivas Regionales del Período Formativo en el Perú*, edited by P. Kaulicke, pp. 147-160. Boletín de Arqueología PUCP. vol. 2. Pontificia Universidad Católica del Perú, Lima.
- Stone-Miller, R.
1995 Art of the Andes from Chavín to Inca. Thames and Hudson, London.
- Tello, J. C.
1943 Discovery of the Chavín Culture in Peru. *American Antiquity* 1:135-160.
- 1960 Chavín: Cultura Matriz de la Civilización Andina. *Publicación Antropológica del Archivo "Julio C. Tello" de la Universidad Nacional Mayor de San Marcos II*. Imprenta de la Universidad de San Marcos, Lima, Peru.
- Terada, K. and Y. Onuki
1982 Excavations at Huacaloma in the Cajamarca Vallery, Peru, 1979. University of Tokyo Press, Tokyo.
- Wells, L. E.
1990 Holocene history of the El Niño phenomenon as recorded in flood sediments of northern coastal Peru. *Geology* 18:1134-1137.
- Williams, C.
1985 A Scheme for the Early Monumental Architecture of the Central Coast of Peru. In *Early Ceremonial Architecture in the Andes*, edited by C. Donnan, pp. 227-240. Dumbarton Oaks Research Library and Collection, Washington.
- 1980 Complejos de pirámides con planta en u: patrón arquitectónico de la costa central. *Revista del Museo Nacional* 44:95-110.